

## Counting Technology Counters, Timers, Tachometers



- **Display counters** electronic, electromechanical and pneumatic
- **Preset counters** electronic and electromechanical
- **Timers** electronic and electromechanical
- **Time Preset Counters**
- **Time relays**
- **Tachometers** electronic
- **Tachometer with Limits**
- **Position displays**
- **Accessories**







## Encoders, Linear Measuring Systems + Connection Technology

## Process Technology

## Counting Technology

## OEM Products and Systems (OPS)

### Encoders, Linear Measuring Systems + Connection Technology

Our portfolio stretches from miniature incremental encoders, via singleturn and multiturn encoders up to ATEX and Heavy Duty products, as well as linear magnetic measuring and draw wire systems. All popular interfaces and fieldbuses are available. Our patented Integrative Technology, Intelligent Sensing Technology as well as Safety Lock™ Design and OptoASIC technology are setting new standards for reliability and performance.

### Counting Technology

Our electromechanical counters and miniature counters for PCB mounting are the ideal time and pulse counters for pumps, lifts/elevators, dryers, UV lamps, kWh counters and much more. Our Codix series offers functional, inexpensive electronic display counters, position indicators, timers and rate indicators. Our electronic preset counters facilitate distributed control and help reduce cycle times.

### Process Technology

Our user-friendly, compact and well thought-out Codix process displays and controllers are suitable for all linear and non-linear analogue signals. Our temperature displays and controllers lend themselves to mounting either in a panel or on a DIN-rail.

### OEM Products and Systems (OPS)

Our new OEM Products and Systems division offers our customers tailor-made product and system solutions. We are in demand as a partner thanks to our 45 years experience in the areas of precision mechanics, optics and electronic engineering. We manage your product idea from development to prototyping, from pilot run to full series production. In addition we offer complete system solutions for display, control or positioning tasks. Here we can turn to our standard products, including encoders, counters and process devices, as well as to further well-engineered system components from approved network partners.

**Table of Contents**

General  
Overview

Type of counters	Series	Display	Panel cut-out W x H [mm]	Reset			Remarks	Page		
				without	man.	electr.				
<b>Display counters electromechanical</b>	Micro- Totaliser	K 46	999999	27 x 14	•	–	–	high shock resistance	36	
		K 47	999999	27 x 14		–	–	panel, base mount	36	
		K 66	999999	27 x 14		–	–	high magnetic and shock resistance	40	
		K 67	999999	27 x 14		–	–	panel, base mount	40	
		K 04	9999	24 x 13		–	–	Panel/PCB/Base mount	44	
		K 05	9999	24 x 13		–	–		44	
		K 06	999999	30 x 13		–	–		44	
		K 07	999999	30 x 13		–	–		44	
			SK 06.1	999999	–		–	–	Counter for DIN Rail	52
			SK 07.1	999999	–		–	–		52
		Mini- Totaliser	W 15/AW 15	99999	e. g. 31 x 20	–	–	–	54	
			W 16/AW 16	999999	e. g. 31 x 20		–	–	Panel/Base and PCB mount	57
			W 17	9999999	e. g. 38 x 24		–	–		57
		Standard- Totaliser	BK 14	9999	33.3 x 25	–	–	–	Panel mount	62
			BK 16	999999	33.3 x 25		–	–		62
			B 15	99999	50 x 25	–	–	–		64
			B 16	999999	50 x 25	–	–	–		64
			B 18	99999999	50 x 25		–	–		64
			MK 14	9999	33.3 x 22	–	–	–		72
			MK 16	999999	33.3 x 22	–	–	–		72
			MK 18	99999999	48 x 24		–	–		72
		E 16	999999	48 x 27	–	–	–	76		
		Pulse counters pneumatic	PMK 14	9999	33,3 x 22	–	–	–	Panel mount	78
			PMK 16	999999	48 x 24	–	–	–		78
			PMK 18	99999999	48 x 24		–	–		78
	Counter with stepper motor	KWH 17	9999999	–	–	–	–	PCB mount for kWh counter	81	
	Counter with double function	HC 77	9999999	45 x 45/ ø50.8		–	–	Panel mount for pulses and time	82	
		SHC 77	9999999	–		–	–	Din mount for pulses and time	85	
		HW 66	999999	45 x 45/ ø50.8		–	–	Panel mount for kWh and time	86	
	<b>Display counters electronic</b>	LCD Display counter	Codix 130	99999999	45 x 22	–	–	–	Panel mount, different functions	87
Codix 131			99999999	45 x 22	–	–	–	e.g. add., sub, direct connection to	90	
Codix 132			99999999	45 x 22	–	–	–	incremental encoders, locking of the	92	
Codix 133			99999999	45 x 22	–	–	–	reset key	94	
LED Display counter		Codix 520	999999	45 x 22	–	–	–	Totaliser	96	
		Codix 521	999999	45 x 22	–	–	–	Totaliser and position display	98	
		Codix 524	999999	45 x 22	–	–	–	Multifunction	100	
		Codix 52U	999999	45 x 22	–	–	–	Universal with dual functions	102	
		Codix 52P	999999	45 x 22	–	–	–	Position display and tachometer	104	
		Codix 540	999999	92 x 45	–	–	–	Totaliser	106	
		Codix 541	999999	92 x 45	–	–	–	Totaliser and position display	108	
		Codix 544	999999	92 x 45	–	–	–	Multifunction	110	
		Codix 54U	999999	92 x 45	–	–	–	Universal with dual functions	112	
		Codix 54P	999999	92 x 45	–	–	–	Position display and tachometer	114	
LCD Modules		190	9999999	–	–	–	–	Module for PCB mount	116	
		192	999999	–	–	–	–	Module for PCB mount	117	
		166	9999	29.4 x 22	–	–	–	Panel mount	118	
		167	999999	29.4 x 22	–	–	–	Panel or PCB mount	119	
		168	999999	29.4 x 22	–	–	–	Panel or PCB mount	119	
		180	99999999	–	–	–	–	Panel or PCB mount	120	
SSI/Posi- tiondisplay	570	999999	92 x 45	–	–	–	Panel mount SSI	121		
Multi-Func- tion-display	571	999999	92 x 45	–	–	–	Panel mount multifunctions	122		

**Table of Contents**

Type of counters		Series	Display	Panel cut-out W x H [mm]	without	Reset man.	electr.	Remarks	Page
<b>Preset counters electronic</b>	LCD Preset counter	901	999999	45 x 45	–	•	•	Panel mount, supplied by battery	126
		923/924	999999	45 x 45	–	•	•	Panel mount, AC or DC-supply with options	128
		903/904	999999	45 x 45	–	•	•	Panel mount, AC or DC-supply	134
	LED Preset counter	715	999999	45 x 45	–	•	•	Panel mount, AC or DC-supply	137
		Codix 716/717	999999	45 x 45	–	•	•	Panel mount , also with Ex or interface	140
	LED Position display	571	999999	92 x 45	–	•	•	Panel mount multifunctions	144
<b>Preset counters electromechanical</b>	BVa 15	99999	50 x 50	–	•	–		145	
	MVs 13	999	50 x 33.3	–	•	•	Panel mount	149	
	MVs 16	999999	50 x 50	–	•	•		152	
<b>Timers electromechanical</b>	Micro timers	HK 46	9999.99 h	27 x 14	•	–	–	Panel or PCB mount high shock resistance, small power consumption	158
		HK 47	99999.99 h	27 x 14	•	–	–		158
		HK 07/AHK 07	999999.99 h	30 x 13	•	–	–	Panel or PCB mount, high shock resistance	159
		HK 07 D	99999.9 h	30 x 13	•	–	–		163
		SHK 07.1	99999.99 h	–	•	–	–	for DIN rail mount	165
	Standard timers	HK 17	999999.99 h	33 x 22	•	–	–		166
		H 37	999999.99 h	e. g. 45 x 22	•	–	–	Panel mount, small size	170
		H 37 S	999999.99 h	e. g. 45 x 22	•	–	–		173
		H 57	999999.99 h	45 x 45	•	–	–		Panel mount
		H 57 S	999999.99 h	45 x 45	•	–	–		177
		AH 57	999999.99	–	•	–	–	for DIN rail mount	176
		HR 76	99999.9 h	ø 50,8	•	–	–	Panel mount, low cost	179
		HB 26	9999.99 h	50 x 25	–	•	–	Panel mount	180
		HB 27	99999.99 h	50 x 25	•	–	–		183
	SH 17	99999.9 h	–	•	–	–	for DIN rail mount	185	
Counter with double function	HC 77	999999.99 h	45 x 45/ø 50.8	•	–	–	Panel mount for time and pulses	186	
	SHC 77	999999.99 h	–	•	–	–	DIN rail mount for time and pulses	188	
	HW 66	999999 h	45 x 45/ ø50.8	•	–	–	Panel mount for time and kWh	189	
<b>Timers electronic</b>	LCD	Codix 134	99999-99 h	45 x 22	–	•	•	Panel mount, battery powered	190
		Codix 135	9999999.9 s	45 x 22	–	•	•		192
	Modul LCD	194	9999-99 h	–	–	–	•	PCB mount	194
		198	99999.9 h	–	–	–	•		195
	LED	Codix 523	999999	45 x 22	–	•	•	Panel mount, timer	196
		Codix 524	999999	45 x 22	–	•	•	Panel mount , multifunction	198
		Codix 52U	999999	45 x 22	–	•	•	Panel mount , universal with dual functions	200
		Codix 543	999999	92 x 45	–	•	•	Panel mount , timer	202
		Codix 544	999999	92 x 45	–	•	•	Panel mount , multifunction	204
		Codix 54U	999999	92 x 45	–	•	•	Panel mount , universal with dual functions	206
<b>Preset timer electronic</b>	LCD	923/924	999999	45 x 45	–	•	•	Panel mount, AC or DC-supply with options	208
		903/904	999999	45 x 45	–	•	•	Panel mount, AC or DC-supply	214
	LED	715	99999	45 x 45	–	•	•	Panel mount, AC or DC-supply	217
		Codix 716/717	999999	45 x 45	–	•	•	Panel mount , also with Ex or interface	220
		571	999999	92 x 45	–	•	•	Panel mount , multifunction	224
<b>Preset timer electromechanical</b>	HVa 15	9999.9 h	50 x 50	–	•	–	Panel mount	225	
<b>Time relay</b>	910	99999	45 x 45	–	•	•	Panel mount, time relay	228	

**Table of Contents**

Type of counter	Series	Display	Panel cut-out W x H [mm]	Reset			Remarks	Page	
				without	man.	electr.			
Tachometer Frequency meters	LCD	Codix 136	12000	45 x 22	–	–	–	Panel mount, tachometer	230
	LED	Codix 522	999999	45 x 22	–	–	–	Panel mount, tachometer	232
		Codix 524	999999	45 x 22	–	•	•	Multifunction	234
		Codix 52U	999999	45 x 22	–	•	•	Universal with dual functions	236
		Codix 52P	999999	45 x 22	–	•	•	Position- and frequency display	238
		Codix 542	999999	92 x 45	–	–	–	Panel mount, tachometer	240
		Codix 544	999999	92 x 45	–	•	•	Multifunction	242
		Codix 54U	999999	92 x 45	–	•	•	Universal with dual functions	244
Codix 54P	999999	92 x 45	–	•	•	Position- and frequency display	246		
Tachometer/Frequency meter with limits	LCD	923/924	999999	45 x 45	–	•	•	Panel mount, AC or DC-supply with options	248
		903/904	999999	45 x 45	–	•	•	Panel mount, AC or DC-supply	254
	LED	715	99999	45 x 45	–	•	•	Panel mount, AC or DC-supply	257
		Codix 716/717	999999	45 x 45	–	•	•	Panel mount, also with Ex or interface	260
		571	999999	92 x 45	–	•	•	Panel mount, multifunction	264
Position display	LCD	Codix 133	99999999	45 x 22	–	•	•	Position display	266
	LED	Codix 521	999999	45 x 22	–	•	•	Totaliser and position display	268
		Codix 524	999999	45 x 22	–	•	•	Multifunction	270
		Codix 52P	999999	45 x 22	–	•	•	Position- and frequency display	272
		Codix 541	999999	92 x 45	–	•	•	Totaliser and position display	274
		Codix 544	999999	92 x 45	–	•	•	Multifunction	276
		Codix 54P	999999	92 x 45	–	•	•	Position- and frequency display	278
	LCD	923/924	999999	92 x 45	–	•	•	Panel mount, AC or DC-supply with options	280
	LED multi.	571	999999	92 x 45	–	•	•	Panel mount, multifunction	286
	SSI	570	999999	92 x 45	–	•	•	SSI display	287

Accessories 288  
 Search by order codes 307

## General instructions

### 1. Electromechanical Pulse counters

The general counter construction consists of an electromagnetic drive and a mechanical kind of

number wheel system. Electrical impulses cause a step-by-step revolution of the number wheels.

#### Adding Pulse Counters

Add the incoming impulses continuously. They are available with or without electrical or manual reset. Miniature counters are also available for battery operation with a power consumption of

only 50 or 30 mW and are protected against shock and vibration to a very high extent.

#### 1.1 Characteristics

##### Current type

Our counters are all constructed for DC voltage. On AC voltages a rectifier is always required and is incorporated in the housing. The maximum permissible voltage fluctuation for DC and AC is

generally  $\pm 10\%$  of the nominal voltage at maximum count frequencies.

##### Residual ripple

is the AC voltage superposed on the DC voltage in %  

$$\frac{U_W}{U_g} \times 100\%$$

$U_W$  = Effective value of superposed AC voltage  
 $U_g$  = arithmetical mean value of DC voltage

##### Power consumption

is the power in W or VA that a pulse counter consumes at continuous pulse and rated voltage

with unheated coil (20 °C)

##### Maximum Pulse Frequency

is the maximum possible count frequency which the counter in question can consume in permanent operation. It differs according to counter

type and power consumption and is limited by the required pickup- and release times of the counting solenoid.

##### Minimum Pulse on time

is the period of time which is sufficient for accurate counting, even at permissible  $\pm$  variation of

operating voltage; the pulse interval can be optionally as long as required.

##### Minimum Pulse Interval

is the period of time which is sufficient for accurate counting. Optimal spark quenching is

imperative if high count frequency is required.

##### Pulse ratio

is the ratio of  $\frac{\text{pulse on time}}{\text{pulse interval}}$

at maximum count frequency.

##### On time ED

states how long a coil may be energized without overheating.

tinuously energized.

The following formula is applicable to the

Example:

$$ED \% = \frac{\text{pulse on time}}{\text{pulse on time} + \text{pulse interval}} \times 100$$

A count coil has the listed value ED = 15 %, max. 55 sec. This coil may therefore remain under constant current for max. 55 sec. After this a cooling interval of

From this can be derived:

$$\text{pulse interval} = \frac{100 - ED \%}{ED \%} \times 55 \text{ s} = 283 \text{ s}$$

$$\text{pulse on time} = \frac{ED \%}{100 - ED \%} \times \text{pulse interval}$$

is required.

$$\text{pulse interval} = \frac{100 - ED \%}{ED \%} \times \text{pulse on time}$$

The same coil is constantly receiving pulses of 40 sec. duration with a count interval of 6 min. Is this still permissible?

In addition to the ED % figure the listed values include an addition concerning the maximum permanent on time. Therefore a coil may only be energized by a constant current during this period and then has to be cooled off again. On ED = 100 % limitation of this is not necessary as this coil will become inadmissibly hot, even if con-

$$ED \% = \frac{40}{40 + 360} \times 100 = 10\%$$

Result:

Since the on time does not exceed 15 % these pulse-on times are permissible.

##### Ambient temperature

is the permissible temperature within the direct vicinity of the pulse counter. When using the counters in groups, the reciprocal heating must

be taken into consideration as this results in an ambient temperature rise. The upper or lower value is only applicable to the rated voltage.

## General instructions

### 2.1 Instructions for electromechanical Pulse Counters

#### 2.2 Pulse Voltages

DC voltage pulses without or with very small residual ripple are, for example, taken from a battery, DC generator, electronically stabilised power supply, according to the circuit above. These are most suitable for the maximum possible frequencies due to their ideal square shape.

If only AC voltage is available it must be rectified. Therefore, according to count speed, a more or less greater degree of residual ripple has to be put up with. A simple bridge-rectifier will give a residual ripple of approx. 50%, and the following relationship is applicable.

AC voltage (effective value)	12	24	48	60	110	220	V
DC voltage (arithm. mean value)	8,5	19,5	40	49	91	185	V

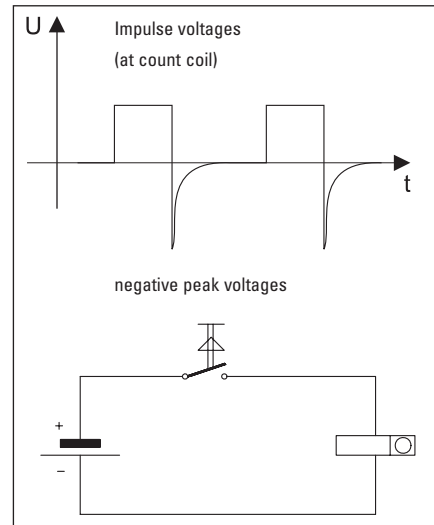

Two types of switching circuits can be used to drive the counters

a) Pulse contact in AC circuit Model a0 or a

This circuit is mostly used when the count speed is  $\leq 18$  Imp/sec.

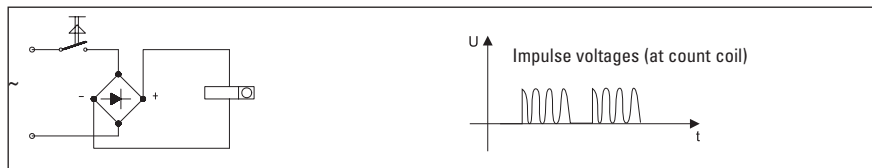

Advantage:

No spark required; contact bounces have no negative effect because the rectifier acts as spark quenching and provides inductive drop-out time lag.

Disadvantages:

Count speed only possible up to max. 18 Imp/sec.

b) Pulse contact in DC circuit version b

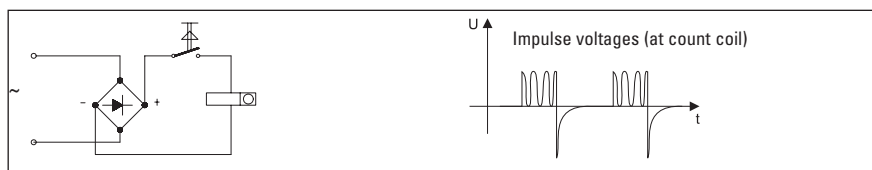

Advantages:

High count speed = 25 /cps, only one rectifier is necessary when driving several counters.

Disadvantages:

More sensitive to contact bounce, spark quenching is required.

4 connection points required if rectifier is built into counter

On pulse speeds  $\geq 30$  Imp/sec smoothed DC must be used. The residual ripple (smoothing degree) is determined by the count speed and is stated in

the technical specification.

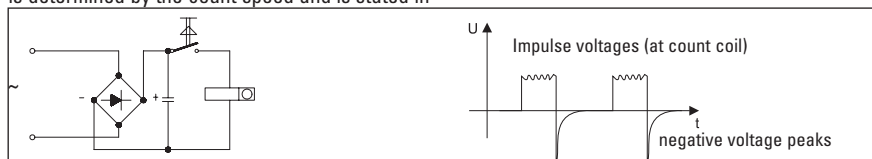

Simple bridge circuit smoothing by capacitor

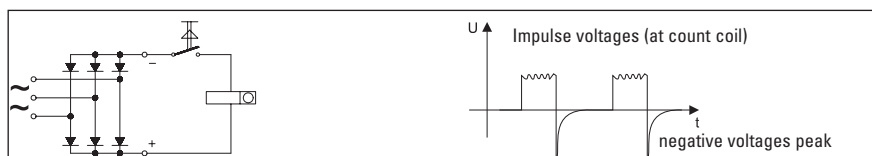

3 phase AC bridge circuit capacitor required . Residual ripple 4.2 %

If the rectifiers are connected directly to AC mains they are often damaged through the contamination of the high peak voltages. These peak voltages are caused by switching of transformers, spot welding machines, switching motors on and off etc; they often exceed the main voltage by many times over. Therefore it is

essential to use a heavy duty rectifier or one with controlled avalanche so that these peak voltages will not have any destructive effects in the long run. This is particularly important in the case of silicon rectifiers which are very sensitive to short period excess voltages. It is advisable to use controlled avalanche silicon rectifiers for

this purpose. Rectifiers which we build in or attach to our pulse counters are to a large extent dielectric, and an over voltage protection is provided, if required.



## General instructions

### 2.3 Pulse Generator

Appropriate pulse generators are required in order to achieve accurate count results. In this connection, it should be ensured that these operate as far as possible without bounce; this is particularly important for counters with high pulse rate. Cam operated spring contacts, limit switch-

es and microswitches are suitable for count speeds up to approx. 10 or 25/cps, small relay contacts up to approx. 40 cps, higher count speed up to 60/cps. can be achieved with reed switches, exact matching of spark quenching being necessary to avoid premature sticking of

contact reeds. Even higher speeds can be obtained by using photoelectric or inductive sensors. Our pulse generators which are manufactured in a robust and solid style are suitable for count speeds up to maximum of 60/cps.

### 2.4 Electrical Reset

Counters with electrical reset have an electromagnet which is operated by a reset pulse, and resets the number wheels back to the starting number. The predetermining counters have a release mechanism which is additionally tensioned. The pre-determining counters can be reset either by remote pulse or automatically. On remote reset through pulse, the pulse duration must be long enough for the reset operation

to be completed and for the minimum pulse duration to be maintained in accordance with the technical data of the counters. It is essential that during resetting no pulses may pass into the count mechanism, as otherwise intermediate positions of the number wheel or slippage of the drive mechanism can occur. There is no danger of mechanical damage of the counter, however. In order to avoid mistakes, the count pulses

should only be allowed to enter, when the number wheels have been accurately adjusted and the drive mechanism is fully engaged. On remote reset a count interval of at least 50 ms after pulse end is required and thus the total count interval = reset pulse time + 50 msec. On counters with automatic reset the count interval must be adhered to according to the technical specifications.

### 2.5 Spark Quenching

If the pulse contact is within the DC circuit of the counter, spark quenching is necessary in order to avoid any contact disturbance from the induc-

tive breaking voltage. Unfortunately, however, a more or less strong dropout delay is produced by the spark quenching and it should be checked in

any case whether this will cause disturbance.

#### 2.5.1 Spark Quenching with RC element

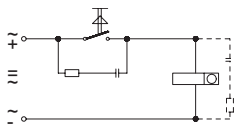

This spark quenching produces practically no disturbing dropout delay and is, therefore most suitable for all count speeds. It should preferably be used at very high count speeds. In general the RC element is located in parallel with the

contact in order to produce high frequency interference suppression at the same time. However, it can also be connected in parallel with the coil. We supply RC elements for any voltage and count speed.

#### 2.5.2 Spark quenching with Diodes

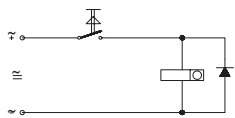

Considerable dropout delay, therefore only suitable for low count speeds up to 10 cps. Particular attention should be paid to the correct polarity on connecting. The small fitting size is an

advantage: e.g. this type of spark quenching can be used for resetting coils.

#### 2.5.3 Spark Quenching with Zener Diodes

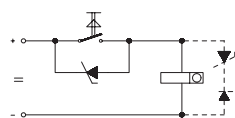

Low dropout delay, therefore suitable for higher count speeds because the diode only passes the inductive breaking current when the Zener voltage is achieved. It is also suitable for the

protection of transistor circuits, where correct polarity also necessary.

#### 2.5.4 Spark Quenching with Varistors

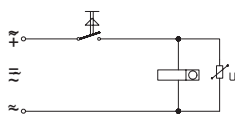

Varistors are voltage dependent resistors whose resistance decreases inertialessly and exponentially with rising voltage. They are therefore, suitable for spark quenching, the varistor ideally being connected in parallel with the coil. It is

rated for the current to be approx. 1/10 of the coil current at nominal voltage.

#### 2.5.5 Identification of counter model

The design of the pulse counters is identified according to type series, version of front panel, e.g.

and reset, according to the following system:

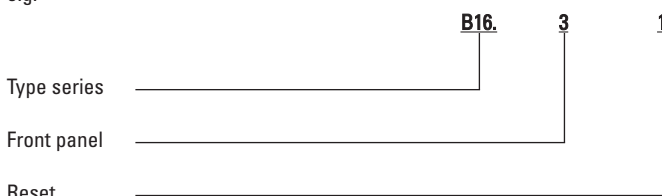

Some products are (UL Underwriters Laboratories Inc.) certified:



## General instructions

### 2.6 Electromechanical standard range

please refer to the technical data for the various counters

#### Front panels

- 0 = no front bezel
- 1 = front bezel for panel with 2 screws
- 2 = front bezel with spring clip mount
- 3 = large front bezel for panel with 2 screws

For further codes, please refer to the respective counters.

#### Reset

- 0 = without reset
- 1 = manual push button reset
- 2 = remote reset
- 3 = remote- and manual reset

### 2.7 Versions with coil

Max. possible frequency depends on the type of coil used:

Coil type	Max. frequency
05 =	8 Hz for DC
0 =	10 Hz for DC
1 =	25 Hz for DC
a0 =	10 Hz for AC
a =	18 Hz for AC

### 2.8 Special versions

These are modifications of standard versions. The most common versions available are listed under the various type series.

### 2.9 General Instructions

In order to avoid queries, please state exact type designation, voltage and pulse frequency and other accessories if required, when ordering. If combinations and special versions are required, please send drawing with circuit diagram. In difficult cases the availability can be clarified by a visit from our agent.

If a counter is only required to operate at a maximum of 10 cps, then one for 25 cps should not be used. This is primarily because of the higher service life of the 10 cps version compared to the 25 cps model. In addition the 10 cps counter has a higher duty cycle and a lower power consumption than the one for 25 cps.

The choice of spark quenching is also very important, particularly at high count speeds (refer to section 2.4 spark quenching). RC element, silicon diodes and some varistors can be obtained from us.

Certain counter types are supplied with a built in spark quenching. It should be ensured that the release contact on the preset counter will not be damaged by excessive breaking current or breaking voltage. If necessary, spark quenching should be provided here as well. The explanations given in the above paragraphs and the technical specifications of each counter should be noted carefully.

### 2.10 Approvals



Many of our products are **UL** (Underwriters Laboratories Inc.) approved.

**CODIX** 717 Multi-function counter in Ex proof version acc. to explosion-proof class EEX D IIC T6.



Kübler is active worldwide and has made a company commitment to protecting the environment. Our product range is RoHS compliant.

## General instructions

### 3. Notes on the use of electronic counters

Electronic counters can be divided into:

- Display Counters
- Preset Counters

#### 3.1.1 Display Counters

These counters have no outputs activated at a specific count value. They are used purely to monitor the count value. The functions range from simple totalizing up to position display (with phase discriminator). Depending on the speed of the events being counted, the count speed can go up to 100 kHz.

Example:



**CODIX 130**



**CODIX 520**

More recent counters have a scale factor, which for example could be used to convert a length measured in inches into meters.

#### 3.1.2 Preset Counters

It is always the job of preset counters to trigger a signal at a particular count value. In the simplest instance this can mean just shutting down a machine, however it could also be the initialisation of control functions (e.g. cutting material to length, transporting parts etc.). Relays, transistors or optocouplers are used as outputs. Relays are suitable for switching heavy loads (up to 2000 VA). The actual switching capacity depends on the model (counter) and can be seen in the data sheet. Most relays are available with a changeover function.

Example:



Type 571



**CODIX 717 (also EX)**



923/924

#### 3.1.3 Time meters

Time meters (timers) measure the time in the unit of time, for which the device is laid out. With electromechanical meters, this time is displayed in hours with one or two decimal places. With the electronic meters, the time base is programmable in hours, minutes or seconds and the resolution is determined by the decimal point.

Here the smallest possible resolution is milliseconds when operating in the short time meter mode (stop watch function). A time base of hours, minutes and seconds can also be programmed.

The time counting starts when the supply voltage is applied to the meter, or is controlled by means of pulses using either the time-interval measuring principle or the pulse width (gate time) principle, with one or two separate inputs.



13x



H 57



H 37



52U

## General instructions

### 3.1.4 Preset Timers

With the preset timers, one or two outputs are additionally available as relay or optocoupler outputs. A particular output is activated, as soon as a pre-selected value is reached. This can occur both in adding or subtracting mode. The signal duration is programmable either as a momentary (timed) pulse or as a maintained (latched) pulse.



Typ 923/924

### 3.1.5. Time Relays

The Time Relay has 24 operating modes available. It can be used as a variable clock pulse generator, or for ON DELay, OFF DELay, One shot or Single Shot timing purposes.



Typ 910

Applications for these devices include service counters and throughput time control of processes such as baking time, drying time etc.

### 3.1.6. Tachometers

Tachometers measure pulses per unit of time, typically pulses per second with frequency measurements or pulses per minute with rotary speed measurement or production quantities and volumes. Two different measurement principles are used: time-interval measurement, where the time between 2 pulses is measured, or gate time (time base), where the number of pulses within a certain time window is measured.



Typ 571

The latest models use a mix of both principles, which offers a fast reaction time coupled with the greatest possible accuracy. Devices with limit values can be used for monitoring rotary speed or rate of production.

## General instructions

### 3.1.7 Position Displays

Position displays are devices, which measure pulses from rotary encoders or linear measurement systems, with incremental pulses or absolute position data. These displayed position values can be scaled using pulse weighting, which means that the display can be converted to any desired magnitude. Quadrature x1, x2 or x4 input pulse evaluation is available on displays that have incremental inputs. Absolute systems are evaluated using the SSI protocol; singleturn as well as multiturn systems can be displayed and evaluated. Our SSI display has a fast clock frequency up to 1MHz, suitable for our absolute encoders. It has numerous programmable measurement functions, a scalable display and a scalable analogue output; there is also a version with serial interface and a version with 2 limit values (alarms).



### 3.2 Count modes

#### Adding

The counter starts from zero and counts up to the programmed preset value, at which an output signal is triggered. The counter is then reset to zero - this can be programmed to happen automatically. The current count value is always displayed.

#### Subtracting

The counter starts from the preset value or from a separate setpoint and counts down to zero, at which an output signal is triggered. The counter is then reset to the preset value. The value displayed corresponds to the difference between the preset value and the count value.

### 3.3 Display Types

Electronic counters are differentiated according to their display type. The most common types of displays used today are liquid-crystal displays (LCD) and light-emitting diodes (LEDs).

Example:



LED display

LCD display

#### LCD displays

LCD displays have the advantage of being very economical. They are available in both, standard versions and in customised versions. The advantage of the customised version is that as well as the count value, it is possible to display the preset value and also additional symbols such as, for example, the status of the outputs. With customised models, the height of the digits and the size of the display can be optimally laid out for the corresponding counter. LCD displays also have the advantage that they are not affected by ambient light and for poorly lit environments they are available with built-in backlighting. Note however that backlit displays do have higher power consumption.

#### LED displays

LED displays are always employed, if units are to be used in environments with diffuse lighting. Due to their self-luminous display, these models are also easy to read even from a long distance. For each segment, LED displays require a current of between 2 and 10 mA. For a 6 digit counter that could mean from 90 to 450 mA. A further disadvantage is that no additional symbols can be displayed. As a rule 7 segment displays are the norm, although 14 segment displays or alphanumeric displays can be used to display message texts.

## General instructions

### 3.4 Outputs

We offer our preset counters with various output options: relay, transistor and optocoupler.

Relays should not be used when switching very small loads. Transistor or optocoupler outputs are better suited to operate the input of a controller. The design of both outputs is basically almost the same.

However with the optocoupler, galvanic isolation is achieved between the unit (counter) and the peripheral (controller) because of an LED and a phototransistor (in one housing). As a rule, with the optocoupler output the emitter and the collector are brought out and may have to be switched externally. Using the appropriate circuit it is possible to achieve either negative polarity (normally closed function) or positive polarity (normally open function).

Optocoupler output with negative polarity

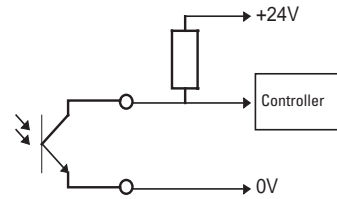

Optocoupler output with positive polarity

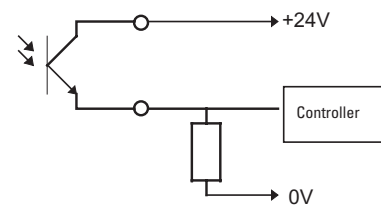

### 3.5 Inputs

The inputs of our counters are designed as transistor inputs. Either NPN or PNP type.

#### 3.5.1 Negative input polarity (NPN)

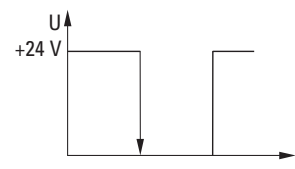
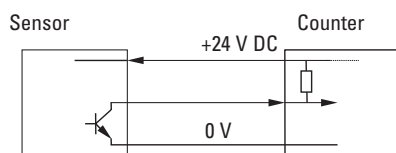

#### 3.5.2 Positive input polarity (PNP)

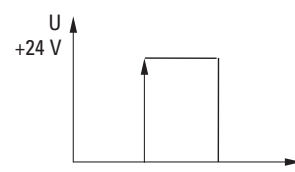
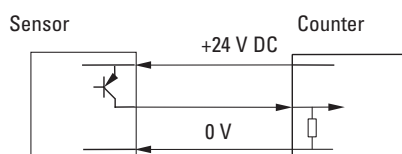

## General instructions

### 3.6 Input Modes

#### 3.6.1 Input mode E1 (Cnt.Dir)

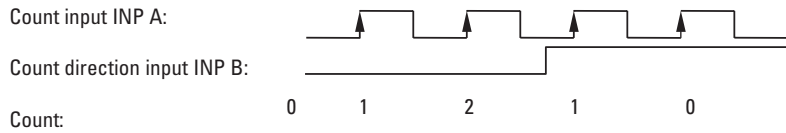

#### 3.6.2 Input mode E2 (up.dn)

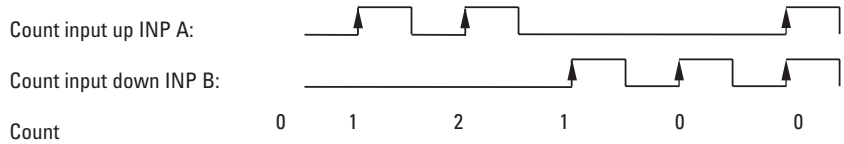

#### 3.6.3 Input mode up.up

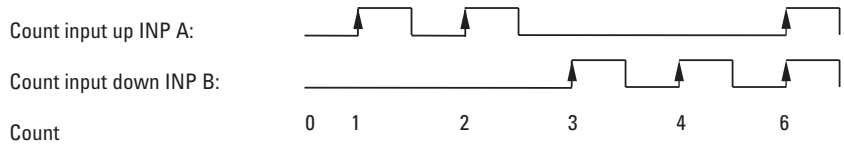

#### 3.6.3 Input mode E3 (Quad)

(phase discriminator/quadrature with recognition of direction)

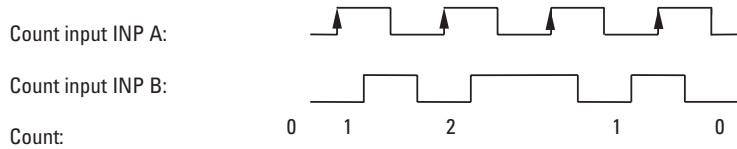

#### 3.6.4 Input mode E4 (Quad 2)

(phase discriminator/quadrature with recognition of direction and pulse doubling)

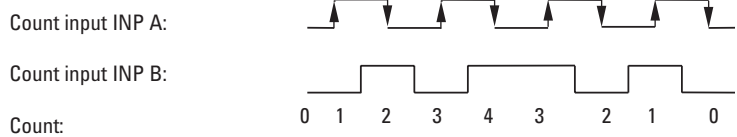

#### 3.6.5 Input mode E5 (Quad 4)

(phase discriminator/quadrature with recognition of direction and pulse quadrupling)

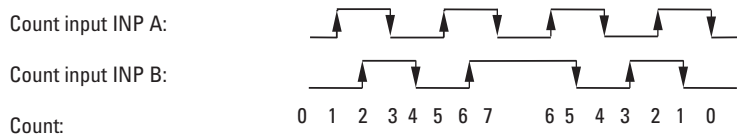

## General instructions

### 3.7 Interface options

Kübler counters use the following serial interfaces:

- RS 232
- RS 422
- RS 485

#### 3.7.1 Serial Interface RS 232

The serial interface RS 232 is a **full-duplex** point-to-point connection. Full-duplex means that data can be both transmitted and received simultaneously via the interface and that only two devices can be connected with each other. If two devices are to be connected to a computer, then a second interface port is required on the computer. The two connections are totally independent from each other. This method has a disadvantage, because interface cards for PLCs are expensive and with PCs a maximum of 4 ports are available for use. For this reason, more recent Kübler counters are equipped with either the

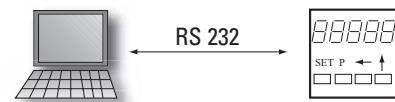

RS 422 or the RS 485 interface. At least a 3-wire cable is needed when connecting RS 232. The connection then works without handshaking. For connections with handshaking a 5-wire cable is needed.

#### 3.7.2 Serial Interface RS 422

This interface is a full-duplex multi-point connection. This means that several receivers can be connected to one transmitter cable. In counting technology the PC or the PLC are used as the master station, which then controls all activity on the serial line. All devices 'listen' to what the master is transmitting, but only that device, which is being addressed, answers. A message can only be sent from one device to another via the master - which does not make much sense with counters. Connecting the PC standard RS 232 port to the RS 422 counter interface is done by means of a simple interface converter. By using this solution, up to 10 devices can be connected to the serial port of a PLC or PC. The wiring is done using a 4-wire cable with all

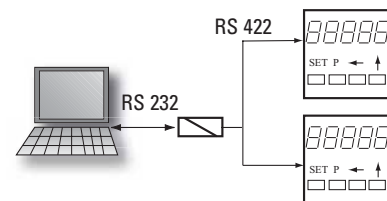

the devices being connected in parallel. Each device has to be assigned a unique address, so that it can distinguish between messages being sent to its own address and those for another address.

#### 3.7.3 Serial Interface RS 485

This interface is a half-duplex multi-point connection. Half-duplex means that the data exchange works in both directions, but only in one direction at a time. It also means that one can transmit and receive over the same line. Converting the common RS 232 interface to RS 485 is not so easily done. However several devices can act as masters as well as also being receivers (slaves). In total up to 32 devices can be connected to one interface.

When connecting the stations together, only a two-wire cable is necessary. Most fieldbuses operate on this interface basis. The hardware is thus always the same, it is only the protocol that differs - this says which device is being addressed, which information is for that device and what control information is required to check that the transmission has been done correctly.



## General instructions

### 3.8 Interface Comparison

Interface	RS 232	RS 422	RS 485
Mode of transmission	asymmetrical with respect to GND	symmetrical with out earth connection	
No. of senders (masters)	1	1	32
No. of receivers (slaves)	1	1	32
Transmission distance	15 m [16.406 yards]	1200 m [1312.15 yards]	1200 m [1312.15 yards]
Transfer rate	20 kBit/s	10 MBit/s	10 MBit/s
Sender output signal without load	+/- 15 Volts	+ 5 Volts	+ 5 Volts
Driver load	3.7 k $\Omega$	120 $\Omega$	60 $\Omega$

### 3.9 EzControl



#### 3.9.1 EzControl - the advantages at a glance

- User-friendly programming software for counter types 716/717 and process indicators 55x
- Upload and download functions
- Monitor and terminal program for simple diagnostics
- Online display of measured values in the monitor program
- Multilingual

see page 193

General instructions

The **CODIX** family – at a glance: Display and Control

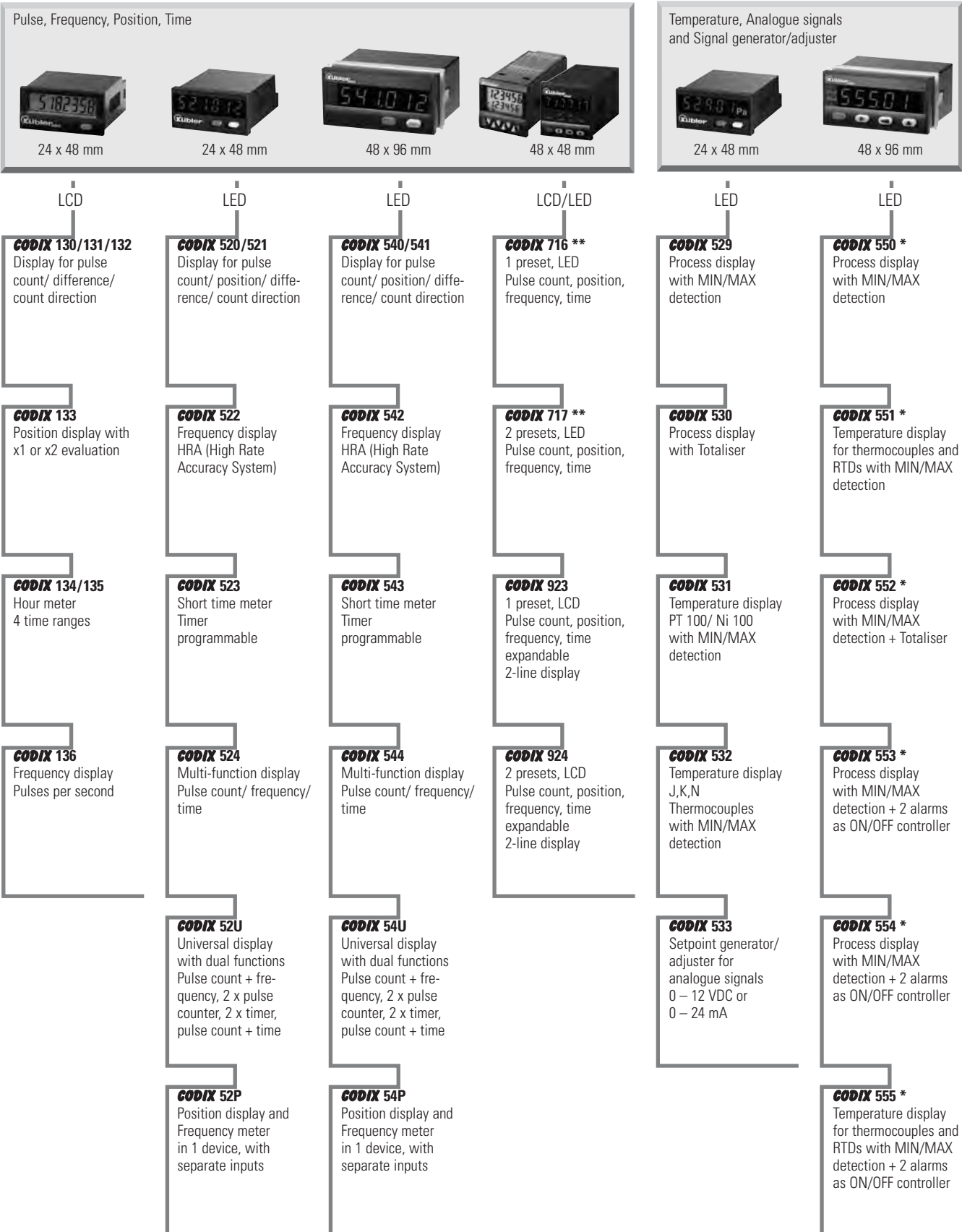

\* with optional interface RS 232/ 485/ 522

\*\* with optional and interface RS 232/ 485/ 522

## Our support for you

### Support

You will find comprehensive support pages on our home page: [www.kuebler.com](http://www.kuebler.com)

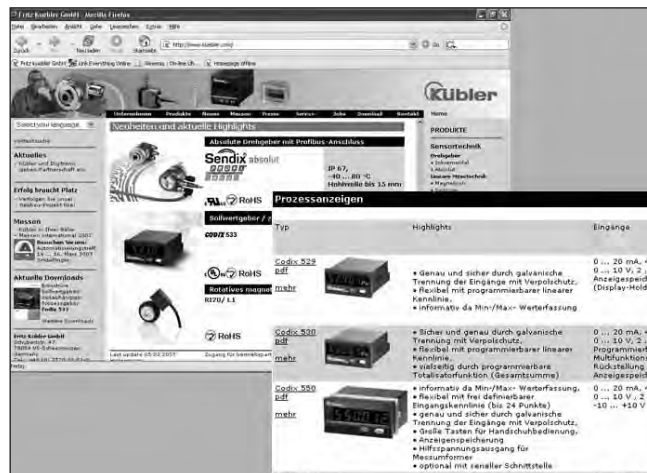

Download our operating instructions from the support area of our home page

Visit our home page. To convince you of the easy programming and use of our products, we give you the possibility to **download the operating instructions before you buy** our products. You simply

need Acrobat Reader to read and print our operating instructions. All operating instructions are available in 3 languages (German, English and French).

### Service

The names of the contact partners in our Service Team can be found on our website under 'Service'. There you will also find an index.

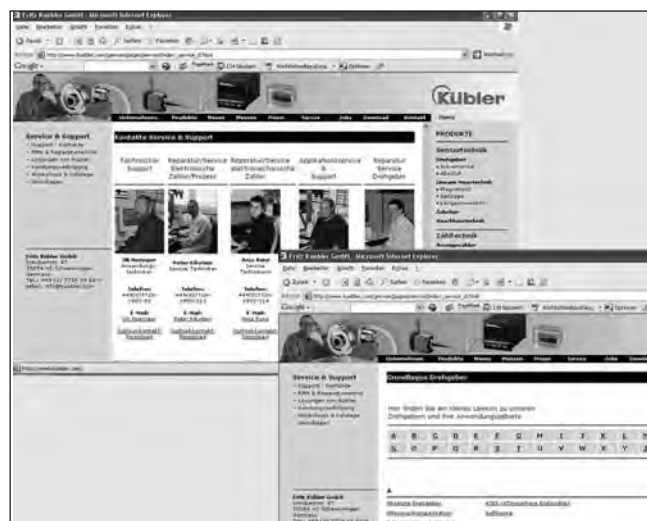

### Repair Service:

If – despite our high quality standards and 100% final testing – you still have a problem with one of our products, then a member of our Service Team will be pleased to help you.

You can contact our Service Team by e-mail at [servicecenter@kuebler.com](mailto:servicecenter@kuebler.com)  
Or you can call us on +49 (0)7720 – 3903 35

## Our support for you

### Personal advice:

Send an e-mail to  
**sales@kuebler.com**  
or call us:  
**+49 (0) 77 20 - 39 03 - 0**

Our technical support team and our sales engineers will give you all information and advice you need.

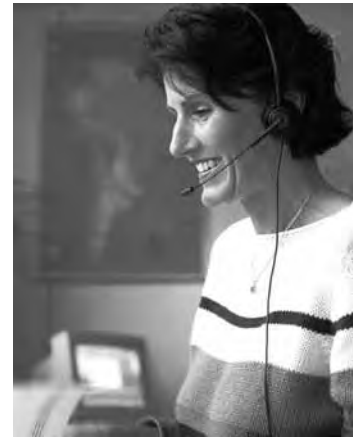

### Modern technology for high quality



Fully-automated SMD assembly.



Wave solder bath – RoHS compliant.



Manufacture of electromechanical counters.

## Micro-Totalisers electromechanical



Version	Micro	Micro	Micro	Micro
Series	K 46/K 47	K 66/K 67	K 04/K 05/AK 05	K 06/K 07/AK 07
<b>Highlights</b>	Shock resistant miniature counters, low power consumption, various models, e.g. for panel-, PCB and base mounting. Suitable for soldering and wash-down (IP 65). For kWh applications, medical equipment, alarm systems, battery-powered units, fuel pumps ...			
<b>Technical data</b>	High shock resistance	100% resistant to shock and magnetic fields	High shock resistance	High shock resistance
Number of digits	6/7	6/7	4/5	6/7
Digit height, visible [mm]	1.7 x 4/1.2 x 4	1.7 x 4/1.2 x 4	1.7 x 4/ 1.2 x 4	1.7 x 4/1.2 x 4
Panel cut-out [mm]	e.g. 27 x 14	e.g. 27x 14	e.g. 24 x 13	e.g. 30 x 13
Viewing angle	variable	variable	variable	variable
Type of mounting	Panel/PCB mount	Panel/PCB mount	Panel/base mount, PCB	Panel/base mount, PCB
Max. protection	up to IP 65	up to IP 65	up to IP 65	up to IP 65
Pulse voltage min/max. [V DC]	1.5 ... 24	1.5 ... 24	3 ... 24	3 ... 24
[V AC]	–	–	24 ... 230	24 ... 230
Max. count frequency [Hz]	10	10	25	25
Min. power consumption [mW]	70	70	50	50
See page	36	40	44	44

## Totalisers electromechanical



Version	DIN-Rail	Mini	Mini	Mini
Series	SK 06.1/SK 07.1	W 15/AW 15	W 16/AW 16	W 17
<b>Highlights</b>	Pulse counter for DIN rail mounting, high shock resistance	Miniature pulse counter for OEM applications. Available in a variety of models, including low cost, and with different mounting options.		
<b>Technical data</b>				
Number of digits	6/7	5	6	5/6/7
Reset	no	yes	no	no
Digit height, visible mm [inches]	1.7 x 4/1.2 x 4	1.7 x 4	1.7 x 4	1.7 x 4
Panel cut-out mm [inches]	–	45 x 22 / 31 x 20	45 x 22 / 31 x 20	45 x 22 / 38 x 24
Viewing angle	front	front	front, top	front, top
Type of mounting	DIN-Rail	Panel, PCB, Base mount	Panel, PCB, Base mount	Panel, PCB, Base mount
Max. protection	IP 50 front side	IP 41	IP 41	IP 41
Pulse voltage min/max. [V DC]	12 / 24	12 / 24	12 / 24	12 / 24
[V AC]	24 / 230	24 / 230	24 / 230	24 / 230
Max. count frequency [Hz]	25	10	10	10
Min. power consumption [mW]	50	130	50	50
See page	52	54	57	57

## Totalisers electromechanical



Version	Industry standard	Industry standard	Industry standard	Industry standard
Series	BK 14	BK 16	B 15/B 16	B 18
<b>Highlights</b>	Robust counter with max. 6 digits, with manual or electrical reset		Robust counter with max. 8 digits, can be combined with preset counters BVa, HVa and MVs 36 series.	
<b>Technical data</b>				
Number of digits	4	6	5/6	8
Reset	yes	no	yes	no
Digit height, visible mm [inches]	2 x 4	2 x 4	2.4 x 4.5/2 x 4.5	2 x 4
Panel cut-out mm [inches]	33.3 x 25	33.3 x 25	50 x 25	50 x 25
Viewing angle	variable	variable	front	front
Type of mounting	Panel	Panel	Panel	Panel
Max. protection	IP 41	IP 41	IP 41	IP 41
Pulse voltage min/max. [V DC]	12 / 24	12 / 24	12 / 24	12 / 24
[V AC]	24 / 230	24 / 230	24 / 230	24 / 230
Max. count frequency [Hz]	25	25	25	25
Min. power consumption [mW]	1 000	1 000	1 000	1 000
See page	62	62	64	64

## Totalisers electromechanical



Version	Industry standard	Industry standard	Industry standard
Series	MK 14	MK 16/18	E 16
<b>Highlights</b>	Rugged counter with up to 8 digits, with or without manual reset / electrical reset.		Rugged counter with metal housing
<b>Technical data</b>			
Number of digits	4	6/8	6
Reset	yes	yes/no	yes
Digit height, visible mm [inches]	4	4	4
Panel cut-out mm [inches]	33.3 x 22	33.3 x 22/48 x 24	48 x 27
Viewing angle	variable	variable	variable
Type of mounting	Panel	Panel	Panel
Max. protection	IP 41	IP 41/IP 52	IP 41
Pulse voltage min/max. [V DC]	12 / 24	12 / 24	12 / 24
[V AC]	24 / 230	24 / 230	24 / 230
Max. count frequency [Hz]	25	25	25
Min. power consumption [mW]	1 000	1 000	2 000
See page	72	72	76

## Pneumatic counters



Version	Industry standard	Industry standard	Industry standard
Series	PMK 14	PMK 16	PMK 18
<b>Highlights</b>	Pneumatic counter, suitable for Ex hazardous areas, easy to use in pneumatic installations, with or without reset. Long-life diaphragm actuator; no leakage.		
<b>Technical data</b>			
Number of digits	4	6	8
Reset	yes	yes	no
Digit height, visible mm [inches]	4	4	4
Panel cut-out mm [inches]	33.3 x 22	48 x 24	48 x 24
Viewing angle	variable	variable	variable
Type of mounting	Panel	Panel	Panel
Max. protection	IP 41	IP 41	IP 52
Pulse voltage min/max. [V DC]	–	–	–
[V AC]	–	–	–
Max. count frequency [Hz]	17	50	50
Min. power consumption [mW]	1.5 - 8 bar	1.5 - 8 bar	1.5 - 8 bar
See page	78	78	78

## Counter with stepper motor/ Counter with double functions



Version	Counter with stepper motor KWH 17	Combination with hour meter and pulse counter HC 77	Energy – Time meter HW 66* <b>New</b>
<b>Highlights</b>	Large digits, stepper motor driven, for PCB mounting in kWh meters, shielded against magnetic effects, low power consumption*.	Pulse and hours-run meter in one unit Time range: 0.01 ... 99 999.99 h	Metering of hours run and energy consumption in one compact device, can be officially calibrated
<b>Technical data</b>			
Number of digits	7	7/8	6
Reset	no	no	no
Digit height, visible mm [inches]	5 x 3	4 x 1.7	4 x 1.7
Panel cut-out mm [inches]	–	□ 46 / ø 50,5	□ 46 / ø 50,5
Viewing angle	front	front	front
Type of mounting	PCB	Panel mount, DIN rail	Panel mount
Max. protection	–	IP 52 front side	IP 65 front side
Pulse voltage min/max.	5 V/10 VDC	10 ... 260 V AC/ DC	115/ 230 V AC
Min. power consumption	25 mW	1 W/ 3 VA	–
Max. count frequency [Hz]	–	10	–
See page	81		

## CODIX - Type 13x



Version	LCD-Panel mount	LCD-Panel mount	LCD-Panel mount	LCD-Panel mount
Series	<b>CODIX 130</b>	<b>CODIX 131</b>	<b>CODIX 132</b>	<b>CODIX 133</b>
<b>Highlights</b>	battery-powered, low-cost LCD counter/rate meter (service life >8 years), count inputs for mechanical contacts or AC/DC voltage pulses. All models have screw terminals. Backlighting optional. ASIC design. High count speed.			
<b>Function</b>				
Totaliser	yes	yes	–	–
Differential	–	yes	–	–
Up-down counting	–	yes*	yes	–
Position display	–	–	–	yes
<b>Technical data</b>				
Number of digits	8	8	8	8
Reset	manual/electrical	manual/electrical	manual/electrical	manual/electrical
Digit height mm [inches]	8	8	8	8
Dimensions mm [inches]	DIN 48 x 24	DIN 48 x 24	DIN 48 x 24	DIN 48 x 24
Max. protection	IP 65 front side	IP 65 front side	IP 65 front side	IP 65 front side
Panel cut-out mm [inches]	45 x 22	45 x 22	45 x 22	45 x 22
Max. count frequency [kHz]	12 000	12 000	30	6 000
Power supply	Lithium-Battery	Lithium-Battery	Lithium-Battery	Lithium-Battery
Count inputs	NPN/PNP 10 ... 260 V AC/DC	NPN/PNP 10 ... 260 V AC/DC	10 ... 260 V AC/DC	NPN/PNP
See page	83	86	88	90

\* only npn/pnp

## Display counters and multifunction displays CODIX 52X



Version	LED Panel mount <b>New</b>	LED Panel mount <b>New</b>	LED Panel mount <b>New</b>	LED Panel mount <b>New</b>
Series	<b>CODIX 520</b>	<b>CODIX 521 ... 524</b>	<b>CODIX 52U</b>	<b>CODIX 52P</b>
<b>Highlights</b>	A re-design and new models expand the field of applications for these compact, powerful LED counters, tachometers and timers. 60 kHz count frequency makes it possible to use these products with encoders, even at high speeds.			
<b>Function</b>			52U Multifunction device with dual functions	52P Position display and tachometer/frequency display
Pulse counter	yes	<b>CODIX 521/524</b>	2 pulse counters, pulse counter and timer,	–
Position display for encoders	–	<b>CODIX 521/524</b>	pulse and frequency meter or 2 timers.	yes*
Frequency meter/rate meter	–	<b>CODIX 522/524</b>		yes*
Timer	–	<b>CODIX 523/524</b>		–
<b>Technical data</b>				
Number of digits	6	6	6	6
Reset	manual/electrical	manual/electrical	manual/electrical	manual/electrical
Digit height mm [inches]	8	8	8	8
Dimensions mm [inches]	DIN 48 x 24	DIN 48 x 24	DIN 48 x 24	DIN 48 x 24
Panel cut-out mm [inches]	45 x 22	45 x 22	45 x 22	45 x 22
Max. protection	IP 65 front side	IP 65 front side	IP 65 front side	IP 65 front side
Max. count frequency [Hz]	60 000	60 000	60 000	30 000
Power supply [V DC]	10 ... 30	10 ... 30	10 ... 30	10 ... 30
Inputs Schmitt-Trigger	NPN/PNP	NPN/PNP	NPN/PNP	NPN/PNP
See page	92	94	98	100

\*separate inputs for frequency and position



## Display counters and multifunction displays **CODIX 54X**



Version Series	LED-Panel mount <b>CODIX 540</b> <i>New</i>	LED-Panel mount <b>CODIX 541...544</b> <i>New</i>	LED-Panel mount <b>CODIX 54U</b> <i>New</i>	LED-Panel mount <b>CODIX 54P</b> <i>New</i>
<b>Highlights</b>	A re-design and new models expand the field of applications for these compact, powerful LED counters, tachometers and timers. 60 kHz count frequency makes it possible to use these products with encoders, even at high speeds.			
<b>Function</b>	54P Position display and tachometer/frequency display		54U Multifunction device with dual functions	
Pulse counter	yes	<b>CODIX 541/544</b>	2 pulse counters, pulse counter and timer, pulse and frequency counter or 2 timers.	–
Position display for encoders	–	<b>CODIX 541/544</b>		yes*
Frequency meter/Tachometer	–	<b>CODIX 542/544</b>		yes*
Time	–	<b>CODIX 543/544</b>		–
<b>Technical data</b>				
Number of digits	6	6	6	6
Reset	manual/electric	manual/electric	manual/electric	manual/electric
Digit height [mm]	14	14	14	14
Dimensions [mm]	DIN 96 x 48	DIN 96 x 48	DIN 96 x 48	DIN 96 x 48
Panel cut-out [mm]	92 x 45	92 x 45	92 x 45	92 x 45
Max. protection	IP 65 front side	IP 65 front side	IP 65 front side	IP 65 front side
Max. count frequency [Hz]	60 000	60 000	60 000	30 000
Supply voltage [V DC]	10 ... 30	10 ... 30	10 ... 30	10 ... 30
[V AC]	90 ... 260	90 ... 260	90 ... 260	90 ... 260
Inputs	Schmitt-Trigger	Schmitt-Trigger	Schmitt-Trigger	Schmitt-Trigger
See page	102	104	108	110

\*separate inputs for frequency and position

## Electronic count modules



Version Series	LCD count module <b>190</b> <i>New</i>	LCD count module <b>192</b>	LCD count modules <b>166/167/168</b>	LCD count modules <b>180</b>
<b>Highlights</b>	7-digit, count frequency up to 10 kHz	6-digit, count frequency up to 100 Hz	LCD panel mount module for OEM pulse counter applications such as portable test equipment (with or without battery supply), current consumption < 10 µA	
<b>Technical data</b>				
Number of digits	7	6	4/6/6	8
Count mode	add.	add.	add./add./add-sub.	add./sub.
Reset	electrical	electrical	electrical	manual/electrical
Height of figures [mm]	6	5	6	8
Dimensions [mm]	32 x 19	32 x 19	31 x 24	47 x 21
Panel cut-out [mm]	–	–	29,4 x 22	–
Type of mounting	PCB mount	PCB mount	Panel/PCB mount	Panel/PCB mount
Max. protection	–	–	IP 40	–
Max. count frequency [Hz]	10 000	100	18/10 000/10 000	10 000
Power supply	4.75 ... 60 V DC	8 ... 28 V DC	Battery <sup>1)</sup> 2.6 ... 3.4 V DC <sup>2)</sup>	2.4 ... 3.2 V DC
See page	112	113	114	116

<sup>1)</sup> 166 <sup>2)</sup> 167/168

## Multifunction displays



Versions	LED Panel mount	LED Panel mount
Series	SSI display	Multifunction display
Highlights	<b>Type 570</b> SSI-clock frequency up to 1 MHz, master or slave mode position display for absolute encoders	<b>Type 571</b> Fast count input for our <b>LIMES</b> system L1 programmable: speed, rotational speed, count and timer functions
<b>Technical data</b>		
Number of digits	6	6
Height of figures [mm]	15	15
Panel cut-out [mm]	92 x 45	92 x 45
Max. protection	IP 65 front side	IP 65 front side
Max. count frequency [Hz]	1 MHz data freq.	100 kHz at count
Supply voltage [V DC]	17 ... 30	16 ... 35
[V AC]	115/230	115/230
Inputs	2	2
Outputs	Scalable analogue output or 2 optocouplers with tracking preset or RS 232/485 interface	
See page	117	118

## Preset counters multifunction



Versions	LCD Panel mount	LCD Panel mount	LCD Panel mount	LED Panel mount
Series	901	923/924 <b>New</b>	903/904	715
Highlights	Simple, low-cost, very easy to programme using decade keyboard, alternative to electromechanical counters	Multifunction preset counters as pulse counters, position indicators, frequency meter, preset timers or elapsed time meters.	Multifunction preset counters as pulse counters, position indicators, frequency displays, preset timers or elapsed time meters. Programmable scaling function or various time ranges. Many operation and output modes. Plug-in screw terminals. Supplied with front gasket and fixing clips.	
<b>Technical data</b>		Expandable with further in- and outputs		
Number of digits/display	6/LCD	6/LCD	6/LCD	5/LED
Dimensions [mm]	DIN 48 x 48	DIN 48 x 48	DIN 48 x 48	DIN 48 x 48
Panel cut-out [mm]	45 x 45	45 x 45	45 x 45	45 x 45
Max. protection	IP 65 front side	IP 65 front side	IP 65 front side	IP 65 front side
Max. count frequency [Hz]	25	55 000	10 000	10 000
Supply voltage [V DC]	Battery (8 Years)	10 ... 30	11 ... 30	11 ... 30
[V AC]	–	90 ... 260	90 ... 260	115/230
Presets	1	923: 1, 924: 2	903: 1, 904: 2	1
Outputs	Relay	Relay or Optocoupler	Relay or Optocoupler	Relay or Optocoupler
Inputs	count, reset and program disable inputs 12 ... 250 V AC/DC	2 count inputs, gate, reset, lock, MPI, 4 optional inputs	2 count inputs, gate, reset and program disable inputs.	count, gate, reset-, latch and key lock input
See page	122		124	127

## Preset counters multifunction/ electromechanical

<p style="color: #e67e22; font-weight: bold; margin: 0;">Codix 716/717 with serial interface and software EzControl</p>	Versions				
	Series	<b>LCD Panel mount CODIX 716/717</b> optional EX proof	<b>LED Panel mount Multifunction counter Type 571</b>	<b>electromechanical adding, panel mount Bva 15</b>	<b>Electromechanical, panel mount Mvs 13/16</b>
Highlights	Multifunction pre-set counters as pulse counters, position indicators, frequency displays, preset timers or elapsed time meters.	Fast count input for our <b>LIMES</b> system programmable: counter and position indicator, speed, rotational speed, time functions and reciprocal speed	Preset changeable during operation, plug-in version available, easy to operate, various front panel sizes		
Technical data					
Number of digits		6/LED	6	5	3/6
Height of figures [mm]		7.5	15	Counter 4.5, Preset 4	4
Panel cut-out [mm]		45 x 45	92 x 45	50 x 50	50 x 33.3 / 50 x 50
Max. protection		IP 65 front side	IP 65 front side	–	–
Max. count frequency [Hz]		20 000	100 kHz at count	25	25
Supply voltage [V DC]		10 ... 30	17 ... 30	24	24
		[V AC]	90 ... 260	115/230	24/115/230
Presets		716: 1, 717: 2	2	1	1
Outputs		Relay or Optocoupler 2 count inputs, gate- and mode input optional RS232/422/485	Scaleable analogue output or 2 optocoupler outputs, programmable as limits or RS232 or 485 interface	Microswitch with changeover contact	Microswitch with changeover contact
See page		130	134	135	139/142

## Hour meters electromechanical

<p style="color: #e67e22; font-weight: bold; margin: 0;">Codix 716/717 with serial interface and software EzControl</p>	Version				
	Series	<b>Miniature HK 46 / HK 47</b>	<b>Miniature HK 07</b>	<b>Miniature/DIN-Rail AHK 07/SHK 07</b>	<b>Panel mount HK 17</b>
Highlights	Shock resistant miniature hour meter for installation in control panels, on PCBs or for DIN-rail mounting. Various models, IP65 (PCB versions can be soldered and washed down). For applications in technical equipment ( medical apparatus, UV-lamps ) and in industrial applications.				
Technical data					
Number of digits		6/7	7	7	7/8
Digit height, visible [mm]		1.7 x 4/ 1.25 x 4	1.2 x 4	1.2 x 4	1.7 x 3.8
Dimensions [mm]		30 x 20/ 30 x 34	32 x 15	45 x 14/ 30 x 75	33 x 22
Panel cut-out [mm]		27 x 14	30 x 13	–	–
Viewing angle		variable	variable	front	front
Type of mounting		Panel mount, PCB	Panel mount, PCB	Base mount/DIN rail	Panel mount
Max. protection		IP 66	up to IP 65	up to IP65	IP 65 front side
Typ. power consumption 5/24 V [mW]		82/135	82/135	82/135	0.5 W – 1.65 VA
Voltage ranges [V DC]		4.5 ... 35	4.5 ... 35	4.5 ...35	10 ... 130
		[V AC]	–	20 ... 264 (SHK)	20 ... 440
See page		148	149	149/155	156

## Hour meters electromechanical



Version	Panel mount	Panel mount	Panel mount	Panel mount
Series	H 37	H 37S	H 57/AH 57	H 57S
<b>Highlights</b>	Low cost, stepper-motor driven hour meters for panel/base mount. Quiet motor running even after >8 years due to a special motor technology.			
<b>Technical data</b>			Short panel mount depth, adapters for □ 55, □ 72 and ø72	Short panel mount depth, adapters for □ 55, □ 72 and ø72
Number of digits	7/8	7/8	7/8	7/8
Time range	0.01 ... 99 999.99 h	0.01 ... 99 999.99 h	0.01 ... 99 999.99 h	0.01 ... 99 999.99 h
Digit height, visible [mm]	1.7 x 4	1.7 x 4	1.7 x 4	1.7 x 4
Dimensions [mm]	DIN 48 x 24/53 x 28	DIN 48 x 24/53 x 28	DIN 48 x 48	DIN 48 x 48
Panel cut-out [mm]	45 x 22/50 x 25	45 x 22/50 x 25	□ 46/ø 50.5	□ 46/ø 50.5
Viewing angle	front	front	front	front
Type of mounting	Panel mount	Panel mount	Panel mount	Panel mount
Max. protection	IP 65 front side	IP 65 front side	IP 65 front side	IP 52 front side
Min. power consumption [W/VA]	0.5/1,2	0.5/1,2	0.5/1,2	0.5/1,2
Voltage ranges	[V DC]	10 ... 130/24	10 ... 30	10 ... 130/24
	[V AC]	20 ... 264/100 ... 264	187 ... 264/100 ... 130	20 ... 440/100 ... 264
See page	160	163	165	167

## Hour meters electromechanical



Version	Panel mount	Panel mount	for DIN rail
Series	HR 76	HB 26 / 27	SH 17
<b>Highlights</b>	Shock-resistant round hour meter, IP 65	with reset, plug-in version available HB 27 without reset	DIN rail hour meter, double module width, with easy connection
<b>Technical data</b>			
Number of digits hour meter	6	6/7	7
Time range	0.1 ... 99 999.9 h	0.01 ... (9)9 999.99 h	0.01 ... 99 999.99 h
Number of digits adding counter	–	different versions	–
Digit height, visible [mm]	1.8 x 3.5	–	1.5 x 3.5
Panel cut-out [mm]	ø 58.7 / 71.1	50 x 25	–
Viewing angle	front	front	front
Type of mounting	Panel mount	Panel mount	DIN rail
Max. protection	IP 65 from all sides	IP 41 front side	IP 65 front side
Min. power consumption [W/VA]	0.08/0.4	0.5/1,2	1/2,5
Voltage ranges	[V DC]	10 ... 80	10 ... 27
	[V AC]	115/230	230
See page	169	170/173	175

## Counter with double functions



Version	<b>Energy – Time meter HW 66*</b>	<b>Combination with hour meter and pulse counter HC 77/SHC 77</b>
Series		
<b>Highlights</b>	<b>New</b> Metering of hours run and energy consumption in one compact device, can be officially calibrated	Pulse and hours-run meter in one compact device
<b>Technical data</b>		
Number of digits hour meter	6	7/8
Time range	0.1 ... 99999.9	0.01 ... 99 999.99 h
Number of digits adding counter	6 (energy)	7 (pulses)
Digit height, visible [mm]	4 x 1.7	4 x 1.7
Panel cut-out [mm]	□ 46 / ø 50,5	□ 46/ø 50,5
Viewing angle	front	front
Type of mounting	Panel mount	Panel mount, DIN rail
Max. protection	IP 65 front side	IP 52 front side
Min. power consumption [W/VA]	–	1/3
Voltage ranges [V DC]	–	10 ... 130
[V AC]	115/ 230	20 ... 264
See page		176/178

\* with run indicator

## Hour meters electronic LCD



Version	<b>LCD Panel mount CODIX 134</b>	<b>LCD Panel mount CODIX 135</b>	<b>LCD count module 194</b>	<b>LCD count module 198</b>
Series				
<b>Highlights</b>	Low cost, battery-powered LCD timer. Screw terminals. IP 65. Optional backlighting. Inputs: PNP, NPN or 10 ... 260 V AC/DC		<b>New</b> PCB mount module with wide temperature range –40 ... +85°C, high shock resistance	PCB mount module with wide temperature range –40 ... +85°C, high shock resistance
<b>Technical data</b>				
Number of digits	7	8	6	6
Time range	0.01 h; h.min	h.min.s; 0.1s	9999-99 h	99999.9 h*
Digit height, visible [mm]	8	8	6	5
Dimension [mm]	DIN 48 x 24	DIN 48 x 24	ca. 32 x 19	ca. 32 x 19
Panel cut-out [mm]	45 x 22	45 x 22	–	–
Max. protection	IP 65 front side	IP 65 front side	–	–
Type of mounting	Panel mount	Panel mount	PCB mount	PCB mount
Voltage range [V DC]	Lithium Battery (service life >8 years)	Lithium Battery (service life >8 years)	4.75 ... 15/9 ... 60	8 ... 28
See page	180	182	184	185

\* with run indicator

## Hour meters electronic LED



Version Series	LED Panel mount <b>CODIX 523/524 New</b>	LED Panel mount <b>CODIX 52U New</b>	LED Panel mount <b>CODIX 543/544 New</b>	LED Panel mount <b>CODIX 54U New</b>
<b>Highlights</b>	523: Time meter 524: multifunction timer, frequency meter, pulse counter or position display 523/524 with set function	New functions, dual functions as time counter and totaliser or 2 time counters or 2 pulse counters or tachometer and totaliser	543: Timer 544: Multifunction timer, frequency meter, pulse counter or position display 543/544 with set function	New functions, dual functions as time counter and totaliser or 2 time counters or 2 pulse counters or tachometer and totaliser
<b>Technical data</b>				
Number of digits	6	6	6	6
Time range	sec, min, h or hh.mm.ss	sec, min, h or hh.mm.ss	sec, min, h or hh.mm.ss	sec, min, h or hh.mm.ss
Digit height, visible [mm]	8	8	14	14
Dimensions [mm]	DIN 48 x 24	DIN 48 x 24	DIN 96 x 48	DIN 96 x 48
Panel cut-out [mm]	45 x 22	45 x 22	92 x 45	92 x 45
Max. protection	IP 65 front side	IP 65 front side	IP 65 front side	IP 65 front side
Type of mounting	Panel mount	Panel mount	Panel mount	Panel mount
Voltage range [V DC]	10 ... 30	10 ... 30	10 ... 30	10 ... 30
[V AC]	–	–	90 ... 260	90 ... 260
See page	186/188	190	192/194	196

## Preset timer electronic

*Codix 716/717 with serial interface and software EzControl*



Version Series	LCD Panel mount <b>923/924 New</b>	LCD Panel mount <b>903/904</b>	LED Panel mount <b>715</b>	LCD Panel mount <b>CODIX 716/717</b>
<b>Highlights</b>	Multifunction preset counters as pulse counters, position indicators, frequency meter, preset timers or elapsed time meters. Expandable with further in- and outputs	Multifunction preset counters as pulse counters, position indicators, frequency displays, preset timers or elapsed time meters. Programmable scaling function or various time ranges. Many operation and output modes. Plug-in screw terminals. Supplied with front gasket and fixing clips.		optional EX proof
<b>Technical data</b>				
Number of digits/display	6/LCD	6/LCD	5/LED	6/LED
Dimensions [mm]	DIN 48 x 48	DIN 48 x 48	DIN 48 x 48	DIN 48 x 48
Panel cut-out [mm]	45 x 45	45 x 45	45 x 45	45 x 45
Max. protection	IP 65 front side	IP 65 front side	IP 65 front side	IP 65 front side
Count frequency max. [Hz]	55 000	10 000	10 000	20 000
Power supply [V DC]	10 ... 30	11 ... 30	11 ... 30	10 ... 30
[V AC]	90 ... 260	90 ... 260	115/230	90 ... 260
Presets	923: 1, 924: 2	903: 1, 904: 2	1	716: 1, 717: 2
Outputs	Relay or Optocoupler	Relay or Optocoupler	Relay or Optocoupler	Relay
Inputs	2 count inputs, gate, reset, lock, MPI, 4 optional inputs	2 count inputs, gate, reset and key lock input	Count, gate, reset, latch and key lock input	2 count inputs, gate- and mode input
See page		198	201	204

## Preset timer electronic/electromechanical

## Time relay/Timer



Version Series	LED Panel mount Type 571	electromechanical HVa 15	Time relay LCD 910
<b>Highlights</b>	Multifunction display, run time monitoring- Scaleable analogue output or optocoupler with tracking preset or RS 232/485 interface	Low-cost preset counter for simple time measurement	Can be used for ON/OFF Delay, clock-pulse generator, 3 control modes (level, edge, edge-trig.), thus 24 programmable operation are possible
<b>Technical data</b>			
Number of digits	6	5	6
Reset	electrical	manual	manual/electrical
Digit height, [mm]	8	Count: 4.5; Preset: 4	6.5/3.5
Dimension [mm]	96 x 48	56 x 66, 53 x 53	DIN 48 x 48
Panel cut-out [mm]	92 x 45	50 x 50	45 x 45
Max. protection	IP 65 front side	IP 42 front side	IP 65 front side
Time range	0.001 s ... 99.59.59 h	0.01h ... 999.99h	sec, min, h
Power supply [V DC] [V AC]	16 ... 35 115/230	10 ... 130 20 ... 264	Replaceable lithium battery
Presets	2	1	1
Outputs		Microswitch with changeover contact	Relay
See page	208	209	212

## Tachometers



Version Series	LCD Panel mount CODIX 136	LED Panel mount CODIX 522/524 <i>New</i>	LED Panel mount CODIX 52U <i>New</i>	LED Panel mount CODIX 52P <i>New</i>
<b>Highlights</b>	Easy to operate frequency indicator, direct display in Hz	522: Tachometer 524: Multifunction as tachometer, pulse counter, timer, position display	Higher count speeds, new functions, dual function also as tachometer and pulse counter	52P Position display and tachometer/frequency display, separate inputs
<b>Technical data</b>				
Number of digits	8	6	6	6
Digit height [mm]	8	8	8	8
Dimensions [mm]	DIN 48 x 24	DIN 48 x 24	DIN 48 x 24	DIN 48 x 24
Panel cut-out [mm]	45 x 22	45 x 22	45 x 22	45 x 22
Max. protection	IP 65 front side	IP 65 front side	IP 65 front side	IP 65 front side
Max. count frequency [kHz]	12	60	60	30
Measurement principle	Gate time	Gate or time interval	Gate or time interval	Gate or time interval
Measuring period or gate time	1/sec	1/sec or 1/min	1/sec or 1/min	1/sec or 1/min
Power supply [V DC] [V AC]	Lithium Battery	10 ... 30	10 ... 30	10 ... 30
Input	NPN/PNP	Schmitt-Trigger	Schmitt-Trigger	Schmitt-Trigger
See page	214	216/218	220	222

3rd Party Brand  
Over 60 Years Experience  
Made in Germany by Kübler



Version Series	LED Panel mount <b>CODIX 542/544</b> <i>New</i>	LED Panel mount <b>CODIX 54U</b> <i>New</i>	LED Panel mount <b>CODIX 54P</b> <i>New</i>	LCD Panel mount <b>923/924</b> <i>New</i>
<b>Highlights</b>	Higher count speeds, new functions, dual function also as tachometer and pulse counter	Higher count speeds, new functions, dual function also as tachometer and pulse counter	Tachometer and position display with separate inputs	Multifunction preset counters, position indicators, frequency meter, preset timers or elapsed time meters. Expandable with further in- and outputs
<b>Technical data</b>				
Number of digits	6	6	6	6
Digit height [mm]	14	14	14	—
Dimensions [mm]	DIN 96 x 48	DIN 96 x 48	DIN 96 x 48	DIN 48 x 48
Panel cut-out [mm]	92 x 45	92 x 45	92 x 45	45 x 45
Max. protection	IP 65 front side	IP 65 front side	IP 65 front side	IP 65 front side
Count frequency max. [kHz]	35	30	30	55
Measurement principle	Gate or time interval	Gate or time interval	Gate or time interval	Gate or time interval
Measuring period or gate time	1/sec or 1/min	1/sec or 1/min	1/sec or 1/min	1/sec or 1/min
Power supply [V DC]	10 ... 30	10 ... 30	10 ... 30	10 ... 30
[V AC]	90 ... 260	90 ... 260	90 ... 260	90 ... 260
Input/Output	Schmitt-Trigger	Schmitt-Trigger	Schmitt-Trigger	Relay or Optocoupler 2 count inputs, gate, reset, lock, MPI, 4 optional inputs
See page	224/226	228	230	200

## Tachometers



Version Series	LCD Panel mount <b>903/904</b>	LED Panel mount <b>715</b>	LED Panel mount <b>CODIX 716/717</b>	LED Panel mount <b>571</b>
<b>Highlights</b>	Multifunction as tachometer, timer and preset counter 903: 1 limit 904: 2 limits	Multifunction as tachometer, timer and preset counter	Multifunction as tachometer, timer and preset counter Optional:  proof	Multifunction as frequency display, frequency from run/operation time, position display or timer
<b>Technical data</b>				
Number of digits	6	5	6	6
Digit height [mm]	Count: 9, Preset: 7	7.5	8	15
Dimensions [mm]	DIN 48 x 48	DIN 48 x 48	DIN 48 x 48	DIN 96 x 48
Panel cut-out [mm]	45 x 45	45 x 45	45 x 45	92 x 45
Max. protection	IP 65 front side	IP 65 front side	IP 65 front side	IP 65 front side
Count frequency max. [kHz]	10	10	20	25
Measurement principle	Gate time	Gate time	Time interval	Time interval
Measuring period or gate time	0.01 ... 99.99 sec	0.01 ... 99.99 sec	1/sec or 1/min	Programmable as required
Power supply [V DC]	11 ... 30	11 ... 30	10 ... 30	16 ... 35
[V AC]	90 ... 260	115/230	90 ... 260	115/230
Inputs/outputs	2 count inputs, gate-, reset- and key lock input/ 1 or 2 alarm outputs	count, gate, reset, latch- and keylock input / 1 relay output	2 count inputs, gate, reset and keylock-input / 2 alarms as relay or optocoupler	2 count in., reset/ 2 optocoupler or analogue outputs or RS232/485 output
See page	232	235	238	242



## Position displays LCD/LED



Version Series	LCD Panel mount <b>CODIX 133</b>	LED Panel mount <b>CODIX 521</b> <i>New</i>	LED Panel mount <b>CODIX 524</b> <i>New</i>	LED Panel mount <b>CODIX 52P</b> <i>New</i>
<b>Highlights</b>	Easy to operate position indicator; direct display of encoder pulses	Position indicator with multiplying and dividing factor, set value and faster speed	Combination device with position indicator, pulse counter, frequency meter and timer function	Position indicator and Tachometer with separate scaleable inputs
<b>Technical data</b>				
Number of digits	8	6	6	6
Digit height [mm]	8	8	8	15
Dimensions [mm]	DIN 48 x 24	DIN 48 x 24	DIN 48 x 24	DIN 48 x 24
Panel cut-out [mm]	45 x 22	45 x 22	45 x 22	45 x 22
Max. protection	IP 65 front side	IP 65 front side	IP 65 front side	IP 65 front side
Count frequency max. [kHz]	6	25 (Quad mode)	25 (Quad mode)	15 (Quad mode)
Counting mode	Single and dual evaluation	Single, dual, quadruple evaluation direction or differential mode	Single, dual, quadruple evaluation direction or differential mode	Single, dual, quadruple evaluation direction or differential mode
Power supply [V DC] [V AC]	Lithium battery	10 ... 30	10 ... 30	10 ... 30
Input	NPN/PNP	Schmitt-Trigger NPN/PNP	Schmitt-Trigger NPN/PNP	Schmitt-Trigger NPN/PNP
See page	244	246	248	250

## Position displays LED



Version Series	LED Panel mount <b>CODIX 541</b> <i>New</i>	LED Panel mount <b>CODIX 544</b> <i>New</i>	LED Panel mount <b>CODIX 54P</b> <i>New</i>
<b>Highlights</b>	Position indicator with multiplying and dividing factor, set value and faster speed	Combination device with position indicator, pulse counter, frequency meter and timer function	Position indicator and Tachometer with separate scaleable inputs
<b>Technical data</b>			
Number of digits	6	6	6
Digit height [mm]	14	14	14
Dimensions [mm]	DIN 96 x 48	DIN 96 x 48	DIN 96 x 48
Panel cut-out [mm]	92 x 45	92 x 45	92 x 45
Max. protection	IP 65 front side	IP 65 front side	IP 65 front side
Count frequency max. [kHz]	25 (Quad mode)	25 (Quad mode)	30
Counting mode	Single, dual, quadruple evaluation direction or differential mode	Single, dual, quadruple evaluation direction or differential mode	Single, dual, quadruple evaluation direction or differential mode
Power supply [V DC] [V AC]	10 ... 30	10 ... 30	10 ... 30
Input	Schmitt-Trigger NPN/PNP	Schmitt-Trigger NPN/PNP	Schmitt-Trigger NPN/PNP
See page	252	254	256

## Positioning multifunction displays

**3** Jahre **Warranty**  
3 Year  
Guarantee  
Made in Germany by Kübler



Versions	LCD Panel mount 923/924 <b>New</b>			LED Panel mount SSI display Type 570	LED Panel mount Multifunction display Type 571
Series	Multifunction preset counters, position indicators, frequency meters, preset timers or elapsed time meters.			SSI-clock frequency up to 1 MHz, master or slave mode	Fast count input for our <b>LIMES</b> system
Highlights	Expandable with further in- and outputs			position display for absolute encoders	programmable: speed, rotational speed, count and timer functions
<b>Technical data</b>					
Number of digits	6			6	6
Height of figures [mm]	Count 9; Preset 7			15	15
Panel cut-out [mm]	45 x 45			92 x 45	92 x 45
Max. protection	IP 65 front side			IP 65 front side	IP 65 front side
Max. count frequency	55 kHz			1 MHz data freq.	100 kHz in count mode
Supply voltage [V DC]	10 ... 30			17 ... 30	16 ... 35
[V AC]	90 ... 260			115/230	115/230
Inputs	2 count, 4 further			4 SSI, Reset	2 count, Reset
Outputs	Relay or Optocoupler 923: 1 Li mit 924: 2 Limits			Scaleable analogue output or 2 optocouplers with tracking preset or RS 232/485 interface	
See page	200			259	258

## Accessories



Enclosures



Transparent covers with key lock



Bezel adapters



Slip-on bezels



Software EzControl

Accessories see page 288

## Table of Contents

Type of counters	Series	Display	Panel cut-out W x H [mm]	Reset			Remarks	Page	
				without	man.	electr.			
Display counters electromechanical	Micro- Totaliser	K 46	999999	27 x 14	•	–	–	high shock resistance	36
		K 47	9999999	27 x 14	•	–	–	panel, base mount	36
		K 66	999999	27 x 14	•	–	–	high magnetic and shock resistance	40
		K 67	9999999	27 x 14	•	–	–	panel, base mount	40
		K 04	9999	24 x 13	•	–	–	Panel/PCB/Base mount	44
		K 05	99999	24 x 13	•	–	–		44
		K 06	999999	30 x 13	•	–	–		44
		K 07	9999999	30 x 13	•	–	–		44
		SK 06.1	999999	–	•	–	–	Counter for DIN Rail	52
		SK 07.1	999999	–	•	–	–		52
	Mini- Totaliser	W 15/AW 15	99999	e. g. 31 x 20	–	•	–	Panel/Base and PCB mount	54
		W 16/AW 16	999999	e. g. 31 x 20	•	–	–		57
		W 17	9999999	e. g. 38 x 24	•	–	–		57
	Standard- Totaliser	BK 14	9999	33.3 x 25	–	•	–	Panel mount	62
		BK 16	999999	33.3 x 25	•	–	–		62
		B 15	99999	50 x 25	–	•	–		64
		B 16	999999	50 x 25	–	•	–		64
		B 18	99999999	50 x 25	•	–	–		64
		MK 14	9999	33.3 x 22	–	•	–		72
		MK 16	999999	33.3 x 22	–	•	–		72
		MK 18	99999999	48 x 24	•	–	–		72
E 16		999999	48 x 27	–	•	•	76		
Pulse counters pneumatic	PMK 14	9999	33,3 x 22	–	•	–	Panel mount	78	
	PMK 16	999999	48 x 24	–	•	–		78	
	PMK 18	99999999	48 x 24	•	–	–		78	
Counter with stepper motor	KWH 17	9999999	–	–	–	–	PCB mount for kWh counter	81	
Counter with double function	HC 77	9999999	45 x 45/ ø50.8	•	–	–	Panel mount for pulses and time	82	
	SHC 77	9999999	–	•	–	–	Din mount for pulses and time	85	
	HW 66	999999	45 x 45/ ø50.8	•	–	–	Panel mount for kWh and time	86	
Display counters electronic	LCD Display counter	Codix 130	99999999	45 x 22	–	•	•	Panel mount, different functions	87
		Codix 131	99999999	45 x 22	–	•	•	e.g. add., sub, direct connection to	90
		Codix 132	99999999	45 x 22	–	•	•	incremental encoders, locking of the	92
		Codix 133	99999999	45 x 22	–	•	•	reset key	94
	LED Display counter	Codix 520	999999	45 x 22	–	•	•	Totaliser	96
		Codix 521	999999	45 x 22	–	•	•	Totaliser and position display	98
		Codix 524	999999	45 x 22	–	•	•	Multifunction	100
		Codix 52U	999999	45 x 22	–	•	•	Universal with dual functions	102
		Codix 52P	999999	45 x 22	–	•	•	Position display and tachometer	104
		Codix 540	999999	92 x 45	–	•	•	Totaliser	106
		Codix 541	999999	92 x 45	–	•	•	Totaliser and position display	108
		Codix 544	999999	92 x 45	–	•	•	Multifunction	110
		Codix 54U	999999	92 x 45	–	•	•	Universal with dual functions	112
		Codix 54P	999999	92 x 45	–	•	•	Position display and tachometer	114
	LCD Modules	190	9999999	–	–	–	•	Module for PCB mount	116
		192	999999	–	–	–	•	Module for PCB mount	117
		166	9999	29.4 x 22	–	–	•	Panel mount	118
		167	999999	29.4 x 22	–	–	•	Panel or PCB mount	119
		168	999999	29.4 x 22	–	–	•	Panel or PCB mount	119
		180	99999999	–	–	–	•	Panel or PCB mount	120
	SSI/Positiondisplay	570	999999	92 x 45	–	–	•	Panel mount SSI	121
Multi-Function-display	571	999999	92 x 45	–	–	•	Panel mount multifunctions	122	
				–	–	–			

## Micro Display counter K 46/K 47 shock resistant



- 6/7-digit micro adding counter
- Low cost
- **High shock resistance**
- Low power consumption; suitable for battery operation
- Small dimensions
- Magnified large figures
- Different mounting solutions
- Flush mount with integrated spring clip (snap in)
- PCB-mount versions
- Solderable and wash proof
- Protection to IP 66
- Stores value also at power failure
- Long service life (50 x 10<sup>6</sup> impulses)

### Applications:

charge counting, KWh registration alarm systems, compact units, copiers, fuel dispensers, medical equipment, miniature pumps, dosing machines, gates, general event counting

### Technical data:

Electrical connection:	flush mount:	flying leads AWG 22 approx. 150 mm [5.906"]
	PCB mount:	solder pins $\varnothing$ 0.64 mm [0.025"]
Power consumption:	up to 12 V DC:	approx. 70 mW
	at 24 V DC:	approx. 150 mW
Rated voltage:	1.5/3/4.5/5/6/12/24 V DC -10 % +20 %	
Counting frequency:	max. 10 Imp/s (type 0)	
Pulse duration:	min. 50 ms	
Pulse interval:	min. 50 ms	
Cycle duration factor:	100 %	
Number of digits:	6 (K46), 7 (K47)	
Counting system:	adding	
Height of figures:	K 46: 4 x 1.7 mm [0.067"] K 47: 4 x 1.25 mm [0.049"] optical	
Colour of figures:	white on black	
Reset:	no reset	
Ambient temperature:	-10 ... +60 °C [14 °F ... 140 °F]	
Soldering temperature:	max. 265 °C, max. 3 sec.	

Mounting position:	number of wheel view horizontal (other on request)
Operating life:	> 50 x 10 <sup>6</sup> impulses
solderable and wash proof types:	K 46.80, K 46.90, K 46.91, K 46.94, K 46.95 K 47.80, K 47.90, K 47.91
protection:	IP 65 (K 46.20, K 47.20: front side)
Housing:	clear plastic
Weight:	12 ... 14 g
Options:	K46.20, K46.80; K47.20 K47.80: flat pin 0.8 x 2.8 mm [0.032 x 0.11"] and push on K 46.9x ... 71: connectors types with spacer (high 6 mm [0.236"] K 47.9x ... 71: Draw. 1)
Further options:	- Different voltages - Counting frequency > 10 Imp/s - Differend colour of figures - Extended temperature range: -30 ... +85 °C or -20 ... +70 °C ...[-22 ... 185 °F or -4 ... 158 °F]

### Series:

Type	Display	el. Connection	Description
K46.20, K47.20	Small side	Flying leads	Panel mount with latch
K46.80, K47.80	Small side	Solder pins	PCB mount wash proof
K46.90, K47.90	Large side	Solder pins	PCB mount wash proof
K46.91, K47.91	Small side	Solder pins	PCB mount wash proof
K46.94	Large side	Solder pins	PCB mount wash proof
K46.95	Small side	Solder pins	PCB mount wash proof

Order code:  
- Article number  
- For options please give exact counter type, voltage and options e.g. 1.700.200.012 K 46.20, 12 V DC/0 temperature range -20 ... +70 °C [-4 ... 158 °F]

Draw 1

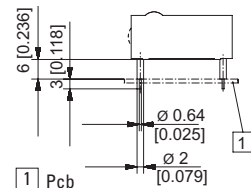

### Type K 46.20/K47.20

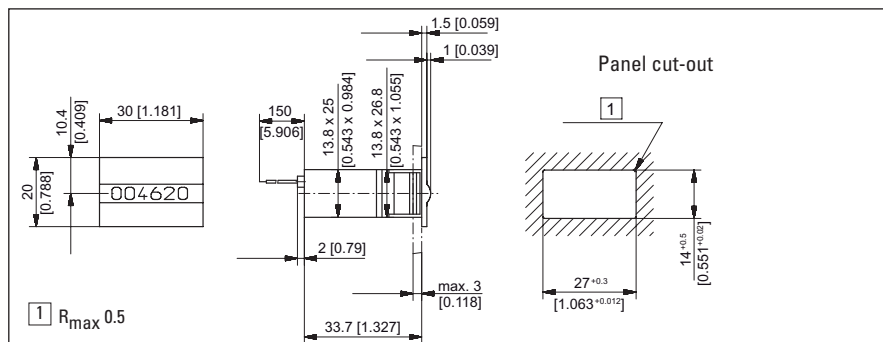

K 46.20	1.5 V	3 V	4.5 V	5 V	6 V	12 V	24 V
	Art. no.	Art. no.	Art. no.	Art. no.	Art. no.	Art. no.	Art. no.
DC (10 Imp/s)	1.700.200.002	1.700.200.006	1.700.200.008	1.700.200.009*	1.700.200.010	1.700.200.012*	1.700.200.013*
K 47.20	1.5 V	3 V	4.5 V	5 V	6 V	12 V	24 V
	Art. no.	Art. no.	Art. no.	Art. no.	Art. no.	Art. no.	Art. no.
DC (10 Imp/s)	1.710.200.002	1.710.200.006	1.710.200.008	1.710.200.009*	1.710.200.010	1.710.200.012*	1.710.200.013*

## Type K 46.80/K 47.80

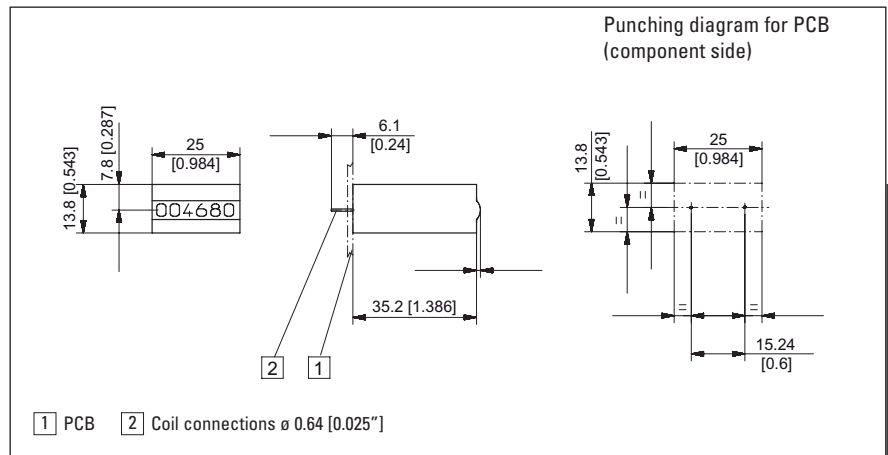

K 46.80	1.5 V Art. no.	3 V Art. no.	4.5 V Art. no.	5 V Art. no.	6 V Art. no.	12 V Art. no.	24 V Art. no.
DC (10 Imp/s)	1.700.800.002	1.700.800.006	1.700.800.008	1.700.800.009	1.700.800.010	1.700.800.012	1.700.800.013*

K 47.80	1.5 V Art. no.	3 V Art. no.	4.5 V Art. no.	5 V Art. no.	6 V Art. no.	12 V Art. no.	24 V Art. no.
DC (10 Imp/s)	1.710.800.002	1.710.800.006	1.710.800.008	1.710.800.009	1.710.800.010	1.710.800.012	1.710.800.013

## Type K 46.90/K 47.90

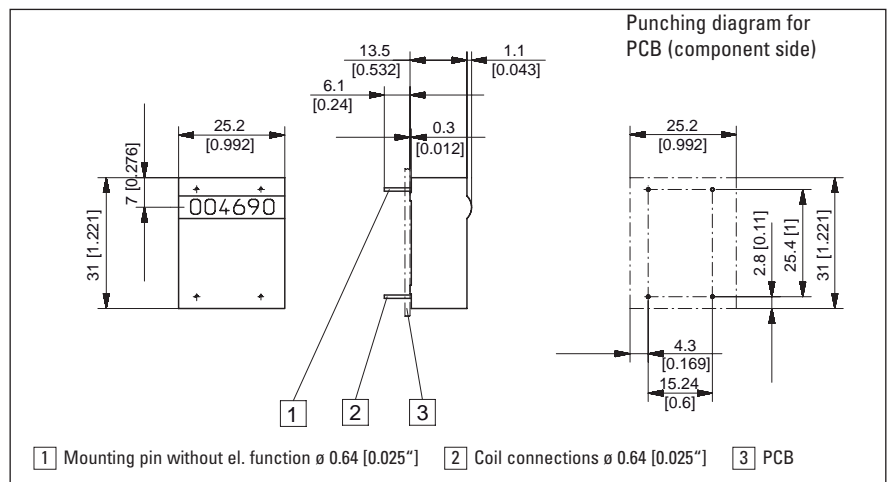

K 46.90	1,5 V Art. no.	3 V Art. no.	4,5 V Art. no.	5 V Art. no.	6 V Art. no.	12 V Art. no.	24 V Art. no.
DC (10 Imp/s)	1.700.900.002	1.700.900.006	1.700.900.008*	1.700.900.009	1.700.900.010*	1.700.900.012	1.700.900.013*

K 47.90	1,5 V Art. no.	3 V Art. no.	4,5 V Art. no.	5 V Art. no.	6 V Art. no.	12 V Art. no.	24 V Art. no.
DC (10 Imp/s)	1.710.900.002	1.710.900.006	1.710.900.008	1.710.900.009	1.710.900.010	1.710.900.012	1.710.900.013

## Type K 46.91/K 47.91

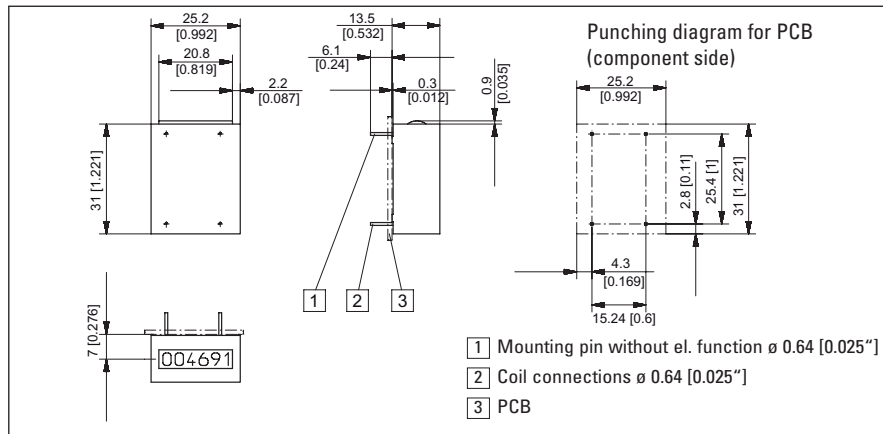

K 46.91	1.5 V	3 V	4.5 V	5 V	6 V	12 V	24 V
	Art. no.	Art. no.	Art. no.	Art. no.	Art. no.	Art. no.	Art. no.
DC (10 Imp/s)	1.700.910.002	1.700.910.006	1.700.910.008	1.700.910.009	1.700.910.010	1.700.910.012	1.700.910.013

K 47.91	1.5 V	3 V	4.5 V	5 V	6 V	12 V	24 V
	Art. no.	Art. no.	Art. no.	Art. no.	Art. no.	Art. no.	Art. no.
DC (10 Imp/s)	1.710.910.002	1.710.910.006	1.710.910.008	1.710.910.009	1.710.910.010	1.710.910.012	1.710.910.013

## Type K 46.94

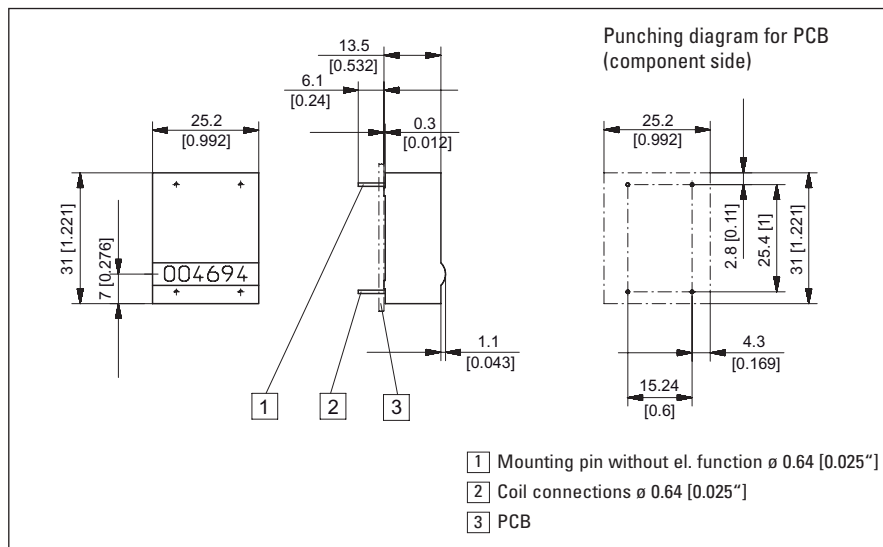

K 46.94	1.5 V	3 V	4.5 V	5 V	6 V	12 V	24 V
	Art. no.	Art. no.	Art. no.	Art. no.	Art. no.	Art. no.	Art. no.
DC (10 Imp/s)	1.700.940.002	1.700.940.006	1.700.940.008	1.700.940.009	1.700.940.010	1.700.940.012	1.700.940.013

## Type K 46.95

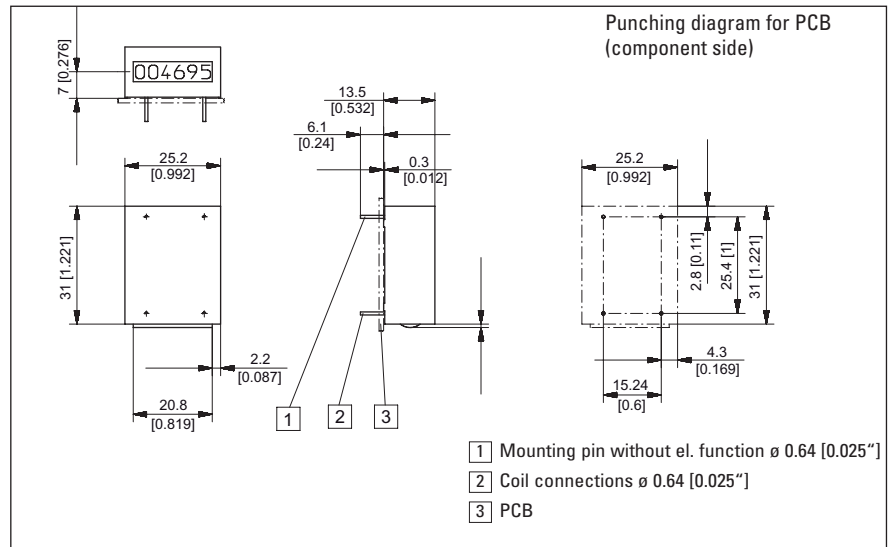
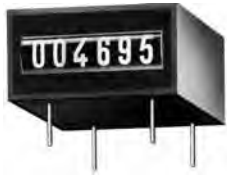

K 46.95	1.5 V Art. no.	3 V Art. no.	4.5 V Art. no.	5 V Art. no.	6 V Art. no.	12 V Art. no.	24 V Art. no.
DC (10 Imp/s)	1.700.950.002	1.700.950.006	1.700.950.008	1.700.950.009	1.700.950.010	1.700.950.012	1.700.950.013

## Micro Display counter K 66, K 67 shock- and magnetic field resistant



- 6/7-digit micro adding counter
- **Not affected by magnetic fields as moving parts are made of plastic or non-ferrous metal (patented system).**
- **Maximum shock resistance, as a counter-rotating movement is required for counting, ACR-system (patented).**
- Low power consumption; suitable for battery consumption
- Small dimensions
- Large optical figures
- Flush mount with integrated spring clip

- PCB-mount versions
- Solderable and wash proof
- Protection IP 65
- Stores value also at power failure
- Long service life

### Applications:

charge counting, KWh registration alarm systems, compact units, copiers, fuel dispensers, medical techniques, miniature pumps, dosing techniques, gates general event counting

### Technical data:

Electrical connection:	flush mount: flying leads AWG 22 approx. 150 mm [5.906"]
	PCB-mount: solder pins $\varnothing$ 0.64 mm [0.025"]
Power consumption:	up to 6 V DC: approx. 70 mW (at 20 °C) at 12 V DC: approx. 120 mW at 24 V DC: approx. 500 mW
Rated voltage:	1.5/3/4.5/5/6/12/24 V DC -10 % +20 %
Counting frequency:	max. 10 Imp/s (type 0)
Pulse duration:	min. 50 ms
Pulse interval:	min. 50 ms
Cycle duration factor:	100 %
Number of digits:	6 (K 66), 7 (K 67)
Counting system:	adding
Height of figures:	K 66: 4 x 1.7 mm [0.067"] K 67: 4 x 1.25 mm [0.049"] optical
Colour of figures:	white on black
Reset:	no reset
Ambient temperature:	-10 ... +60 °C [14 ... 140 °F]
Soldering temperature:	max. 265 °C, max. 3 sec.

Mounting position:	number of wheel view horizontal (other on request)
Operating life:	> 50 x 10 <sup>6</sup> pulses
solderable and wash proof types	K 66.80, K 66.90, K 66.91, K 66.94, K 66.95 K 67.80, K 67.90, K 67.91
Protection:	IP 65 (K 66.20, K 67.20: only front side)
Housing:	clear plastic, types with protection IP 65 are sealed
Weight:	9 ... 11 g [0.317 ... 0.388 oz]
<b>Options:</b>	
K 66.20, K 66.80, K 67.20, K 67.80:	flat pin 0.8 x 2.8 mm [0.032 x 0.11"] and push on connectors
K 66.20, K 67.20:	solder pins $\varnothing$ 0.64 mm [0.025"]
K 66.9x ... 71, K 67.9x ... 71:	types with spacer (High 6 mm [0.236"] Draw.1)
<b>Further options:</b>	
	different voltages, counting frequency > 10 Imp/s different colour of figures, extended temperature range -30 ... +85 °C or -20 ... +70 °C, [-22 ... 185 °F or -4 ... 158 °F]

### Series:

Type	Display	el. Connection	Description
K66.20, K 67.20	Small side	Flying leads	Panel mount with latch
K66.80, K 67.80	Small side	Solder pins	PCB mount wash proof
K66.90, K 67.90	Large side	Solder pins	PCB mount wash proof
K66.91, K 67.91	Small side	Solder pins	PCB mount wash proof
K66.94	Large side	Solder pins	PCB mount wash proof
K66.95	Small side	Solder pins	PCB mount wash proof

Order code:  
 - Article number 1.680.9X0.XXX  
 - For options please give exact counter type, voltage and options e.g. K 66.20, 9 V DC/0 temperature range -20 ... +70 °C [-4 ... 158 °F]

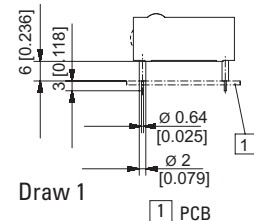

### Type K 66.20/K 67.20

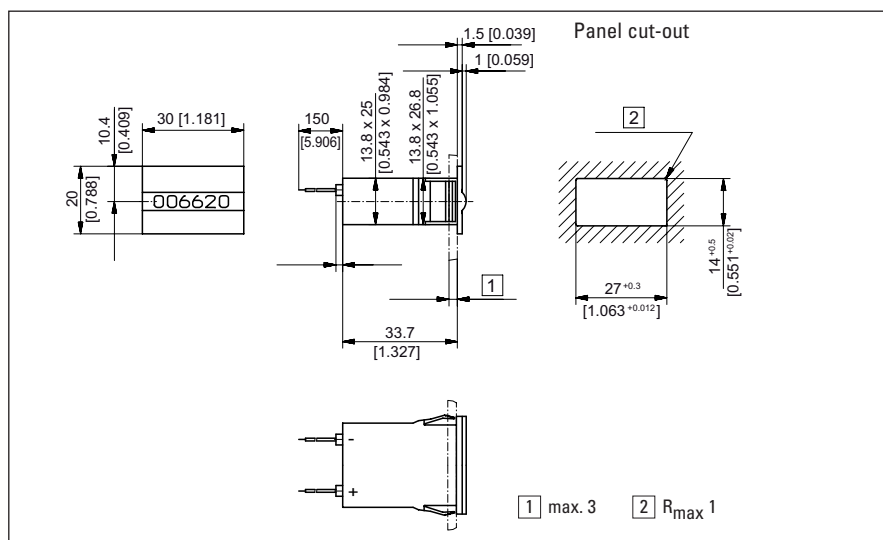

Order code see next page.



## Type K 66.20/K 67.20

K 66.20	1.5 V Art. no.	3 V Art. no.	4.5 V Art. no.	5 V Art. no.	6 V Art. no.	12 V Art. no.	24 V Art. no.
DC (10 Imp/s)	1.650.200.002	1.650.200.006	1.650.200.008	1.650.200.009	1.650.200.010	1.650.200.012	1.650.200.013
K 67.20	1.5 V Art. no.	3 V Art. no.	4.5 V Art. no.	5 V Art. no.	6 V Art. no.	12 V Art. no.	24 V Art. no.
DC (10 Imp/s)	1.660.200.002	1.660.200.006	1.660.200.008	1.660.200.009*	1.660.200.010	1.660.200.012*	1.660.200.013*

## Type K 66.80/K 67.80

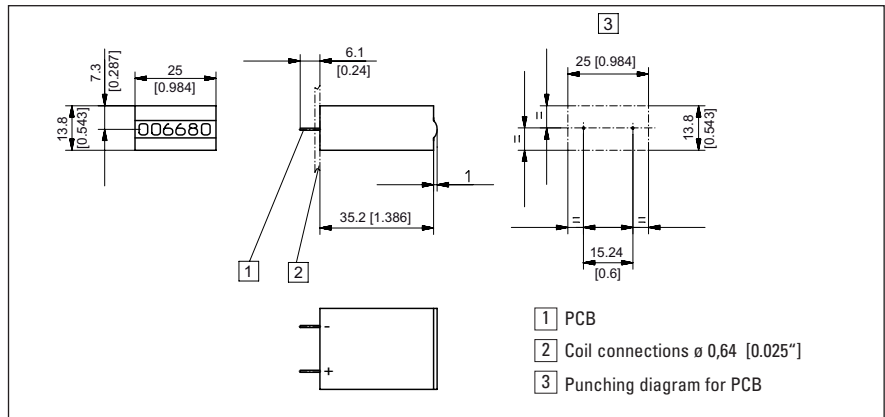

K 66.80	1.5 V Art. no.	3 V Art. no.	4.5 V Art. no.	5 V Art. no.	6 V Art. no.	12 V Art. no.	24 V Art. no.
DC (10 Imp/s)	1.650.800.002	1.650.800.006	1.650.800.008	1.650.800.009	1.650.800.010	1.650.800.012	1.650.800.013
K 67.80	1.5 V Art. no.	3 V Art. no.	4.5 V Art. no.	5 V Art. no.	6 V Art. no.	12 V Art. no.	24 V Art. no.
DC (10 Imp/s)	1.660.800.002	1.660.800.006	1.660.800.008	1.660.800.009	1.660.800.010	1.660.800.012	1.660.800.013

## Type K 66.90/K 67.90

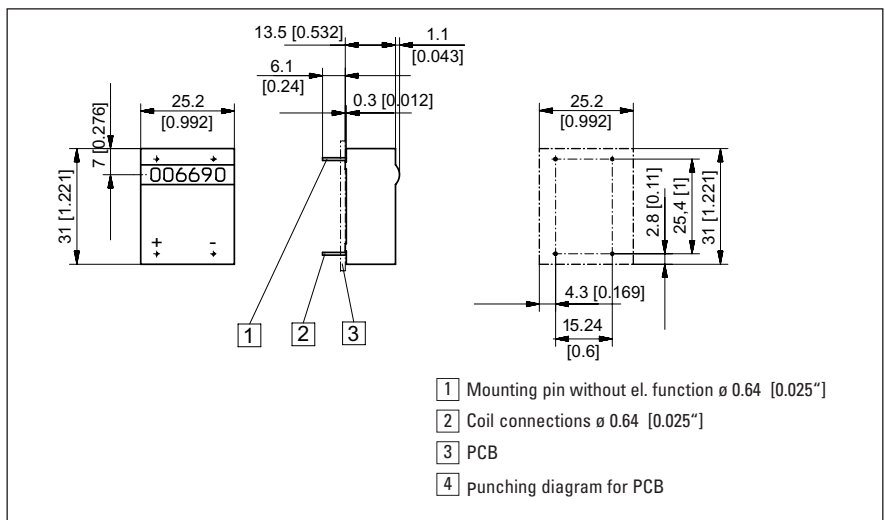

K 66.90	1.5 V Art. no.	3 V Art. no.	4.5 V Art. no.	5 V Art. no.	6 V Art. no.	12 V Art. no.	24 V Art. no.
DC (10 Imp/s)	1.650.900.002	1.650.900.006	1.650.900.008	1.650.900.009*	1.650.900.010	1.650.900.012	1.650.900.013
K 67.90	1.5 V Art. no.	3 V Art. no.	4.5 V Art. no.	5 V Art. no.	6 V Art. no.	12 V Art. no.	24 V Art. no.
DC (10 Imp/s)	1.660.900.002	1.660.900.006	1.660.900.008	1.660.900.009	1.660.900.010	1.660.900.012	1.660.900.013

## Type K 66.91/K 67.91

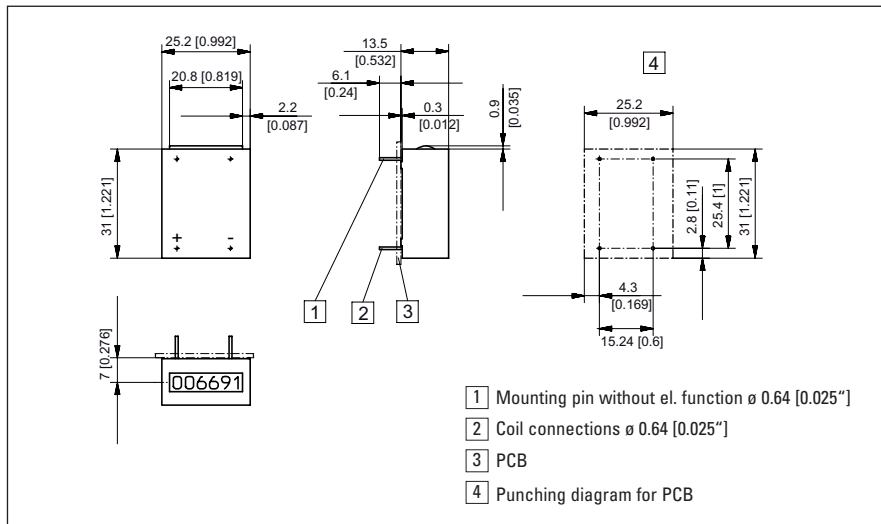

K 66.91	1.5 V Art. no.	3 V Art. no.	4.5 V Art. no.	5 V Art. no.	6 V Art. no.	12 V Art. no.	24 V Art. no.
DC (10 Imp/s)	1.650.910.002	1.650.910.006	1.650.910.008	1.650.910.009	1.650.910.010	1.650.910.012	1.650.910.013

K 67.91	1.5 V Art. no.	3 V Art. no.	4.5 V Art. no.	5 V Art. no.	6 V Art. no.	12 V Art. no.	24 V Art. no.
DC (10 Imp/s)	1.660.910.002	1.660.910.006	1.660.910.008	1.660.910.009	1.660.910.010	1.660.910.012	1.660.910.013

## Type K 66.94

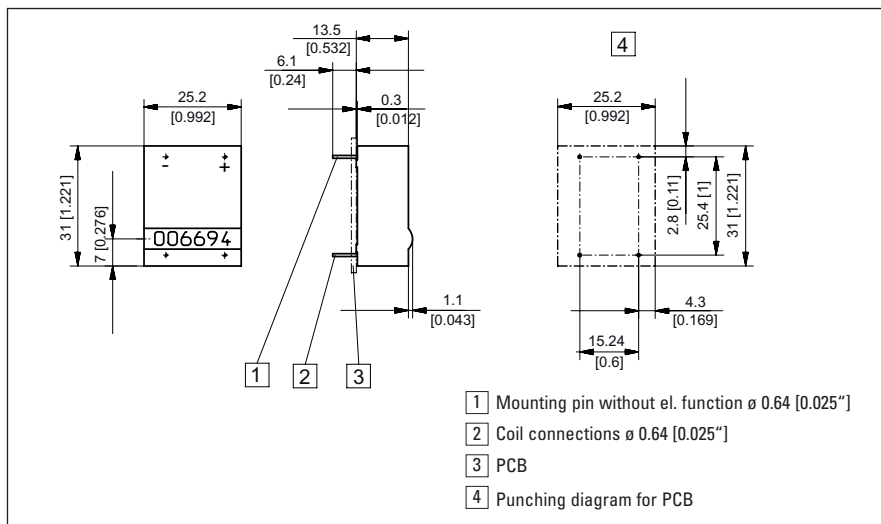

K 66.94	1.5 V Art. no.	3 V Art. no.	4.5 V Art. no.	5 V Art. no.	6 V Art. no.	12 V Art. no.	24 V Art. no.
DC (10 Imp/s)	1.650.940.002	1.650.940.006	1.650.940.008	1.650.940.009	1.650.940.010	1.650.940.012	1.650.940.013

## Type K 66.95

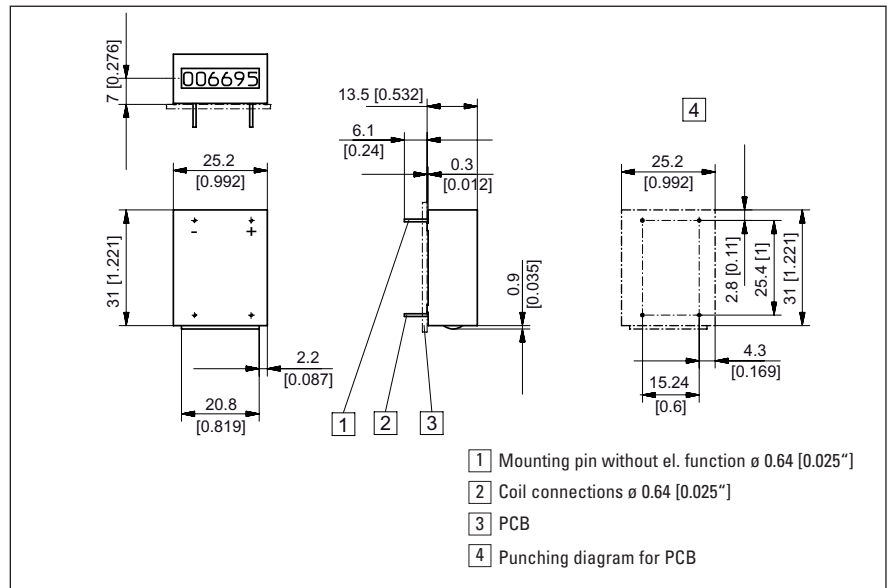

K 66.95	1.5 V Art. no.	3 V Art. no.	4.5 V Art. no.	5 V Art. no.	6 V Art. no.	12 V Art. no.	24 V Art. no.
DC (10 Imp/s)	1.650.950.002	1.650.950.006	1.650.950.008	1.650.950.009	1.650.950.010	1.650.950.012	1.650.950.013

## Micro Display counter K 04 ... K 07, shock resistant



- 4-, 5-, 6- and 7-digit micro adding counter
- High shock resistance
- Low power consumption; suitable for battery consumption
- Small dimensions
- Large optical figures
- Different viewing possibilities
- Flush mount with integrated spring clip
- PCB-mount versions
- Solderable and wash proof
- Protection IP 65

- Stores value also at power failure
- Long service life
- cULus certified (UL Underwriters Laboratories Inc.)

### Applications:

charge counting, kWh registration alarm systems, compact units, copiers, fuel dispensers, medical equipment, miniature pumps, dosing machines, gates, general event counting

### Technical data:

Electrical connection:	built-in: flying leads counter: AWG 22 approx. 150 mm [5.906"] PCB counter: solder pins 0.4 x 1,2 mm [0.016 x 0.047"]	Mounting position:	number of wheel view horizontal (other on request)
Power consumption:	at 10 Imp/s (type 0): approx. 50 mW at 25 Imp/s (type 1): approx. 250 mW at 10 Imp/s (type a0): approx. 800 mVA	Operating life:	> 50 x 10 <sup>6</sup> pulses
Rated voltage:	type 0: 1.5/3/4.5/5/6/12 V DC -10 % +20 % type 1: 3/4.5/5/6/12/24 V DC ± 10 % type 4: 24 V DC -10 % +20 % type a0: 12/24/115/230 V AC ± 10 %	solderable and wash proof types:	K 04.92, K 05.92, K 06.90, K 06.92, K 07.90 K 07.92
Counting frequency:	max. 10 and 25 Imp/s	Protection:	K 04.92, K 05.92, K 06.90, K 06.92, K 07.90 K 07.92: IP 65 (K 04.20, K 05.20, K 06.20, K 07.20: IP 65 only front side) others, depending on kind of mounting
Pulse duration:	at 10 Imp/s (type 0 and a0): min. 50 ms at 25 Imp/s (type 1): min. 20 ms	UL-certified:	File E43429
Pulse interval:	at 10 Imp/s (type 0 and a0): min. 50 ms at 25 Imp/s (type 1): min. 20 ms	Housing:	clear plastic or steel (see table "Series") types with protection IP 65 are fully sealed enclosure
Cycle duration factor:	100 %	Weight:	15 ... 18 g [0.529 ... 0.635 oz]
Number of digits:	4, 5, 6 and 7	Options:	K 0x.20
Counting system:	adding		Flat pin 0.5 x 2.8 mm [0.02 x 0.11] Art.-No.: 1.1X7.XX0.XXX
Height of figures:	K 04, K 06: 1.7 x 4 mm [0.067 x 0.158"] optical K 05, K 07: 1.2 x 4 mm [0.047 x 0.158"] optical		- Different voltages - Version not potted - Different figure colours - Different lengths of flying leads - Different connections - Different temperature range, depends on version
Colour of figures:	white on black		-30 ... +85 °C, -20 ... +70 °C [-22 ... 185 °F, -4 ... 158 °F]
Reset:	no reset		
Ambient temperature:	-10 ... +60 °C [14 ... 140 °F]		
Soldering temperature:	max. 265 °C, max. 3 sec.		

### Series:

4 digit	5 digit	6 digit	7digit	Housing	Display	Description
K 04.20	K 05.20	K 06.20	K 07.20	Plastic	Small side	Flush mount
K 04.40	K 05.40	K 06.40	K 07.40	Steel	Large side	PCB mount
K 04.50	K 05.50	K 06.50	K 07.50	Steel	Small side	PCB mount
K 04.80	K 05.80	K 06.80	K 07.80	Plastic	Small side	PCB mount
K 06.90	K 07.90			Plastic	Large side	PCB mount wash proof
K 04.92	K05.92	K 06.92	K 07.92	Plastic	Small side	PCB mount wash proof

### Order code:

- Article number
- For options please give exact counter type, voltage and options e.g. K 06.20, 9 V DC/0 temperature range -20 ... +70 °C, [-4 ... 158 °F]

## Type K 04.20 and K 05.20

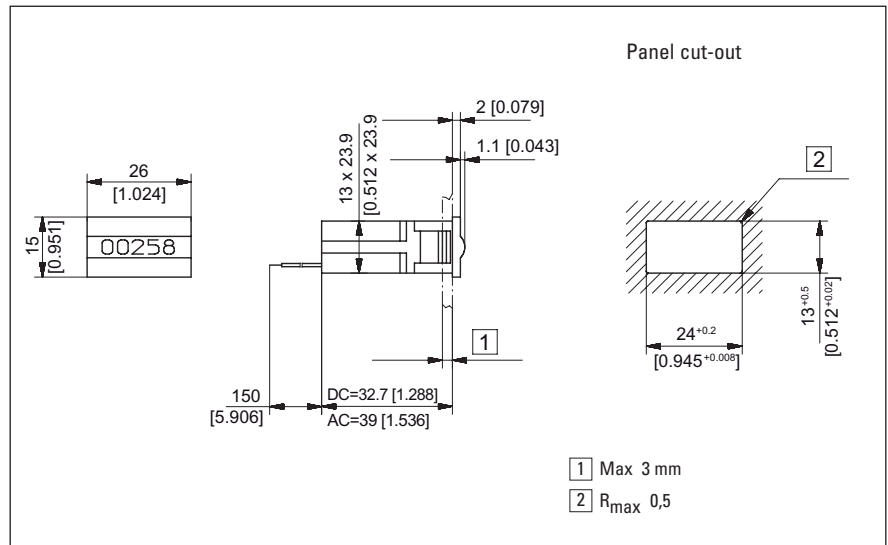

K 04.20 (4-digit)	3 V Art. no.	4.5 V Art. no.	12 V Art. no.	24 V Art. no.	115 V Art. no.	230 V Art. no.
DC (10 Imp/s)	1.100.200.006	1.100.200.008	1.100.200.012	1.100.200.418		
DC (25 Imp/s)			1.100.200.032	1.100.200.033		
AC (10 Imp/s)				1.100.200.051	1.100.200.054	1.100.200.056

K 05.20 (5-digit)	3 V Art. no.	4.5 V Art. no.	12 V Art. no.	24 V Art. no.	115 V Art. no.	230 V Art. no.
DC (10 Imp/s)	1.110.200.006	1.110.200.008	1.110.200.012	1.110.200.418		
DC (25 Imp/s)			1.110.200.032	1.110.200.033		
AC (10 Imp/s)				1.110.200.051	1.110.200.054	1.110.200.056

## Type K 06.20 and K 07.20

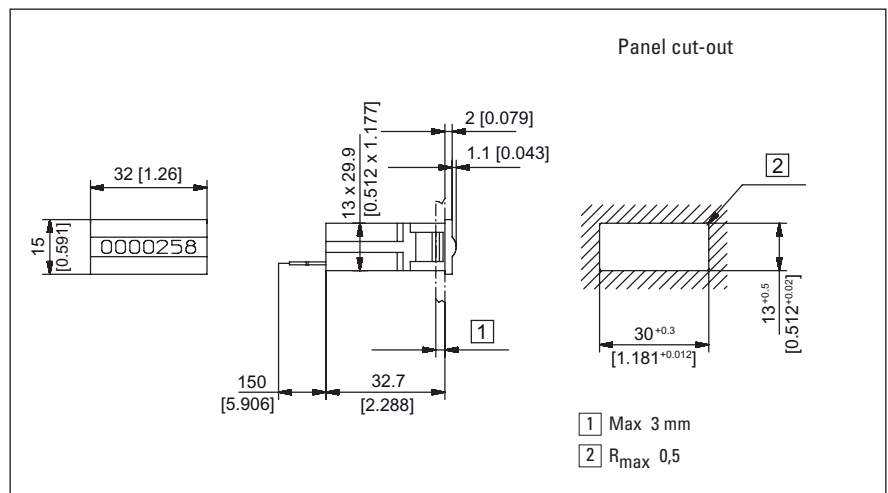

K 06.20 (6-digit)	3 V Art. no.	4.5 V Art. no.	12 V Art. no.	24 V Art. no.	115 V Art. no.	230 V Art. no.
DC (10 Imp/s)	1.120.200.006	1.120.200.008	1.120.200.012	1.120.200.418		
DC (25 Imp/s)			1.120.200.032	1.120.200.033		
AC (10 Imp/s)				1.120.200.051	1.120.200.054	1.120.200.056

K 07.20 (7-digit)	3 V Art. no.	4.5 V Art. no.	12 V Art. no.	24 V Art. no.	115 V Art. no.	230 V Art. no.
DC (10 Imp/s)	1.130.200.006	1.130.200.008	1.130.200.012*	1.130.200.012		
DC (25 Imp/s)			1.130.200.032*	1.130.200.033*		
AC (10 Imp/s)				1.130.200.051	1.130.200.054*	1.130.200.056*

## Type K 04.40 and K 05.40

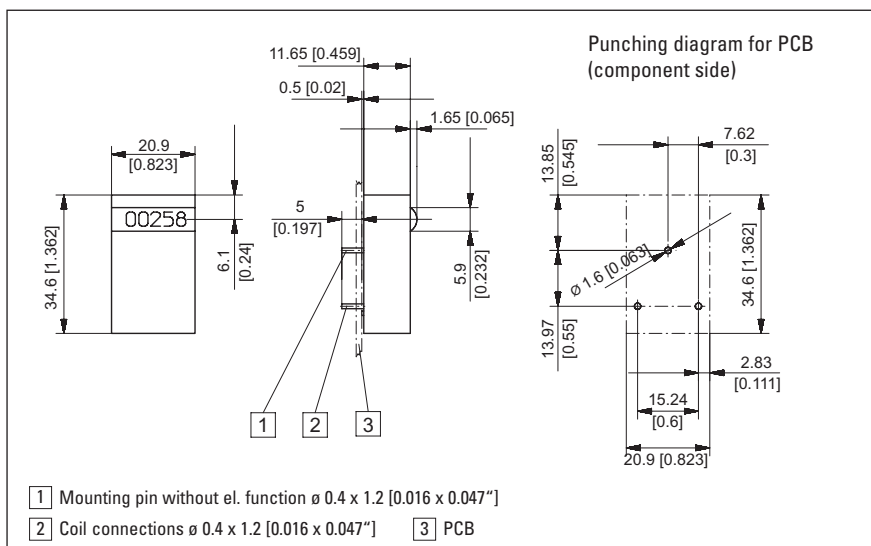

K 04.40 (4-digit)	3 V Art. no.	4.5 V Art. no.	12 V Art. no.	24 V Art. no.
DC (10 Imp/s)	1.100.401.006	1.100.401.008	1.100.401.012	1.100.401.418
DC (25 Imp/s)			1.100.401.032	1.100.401.033

Colour of housing blue (zinc-plated)

K 05.40 (5-digit)	3 V Art. no.	4.5 V Art. no.	12 V Art. no.	24 V Art. no.
DC (10 Imp/s)	1.110.401.006	1.110.401.008	1.110.401.012	1.110.401.418
DC (25 Imp/s)			1.110.401.032	1.110.401.033

## Type K 06.40 and K 07.40

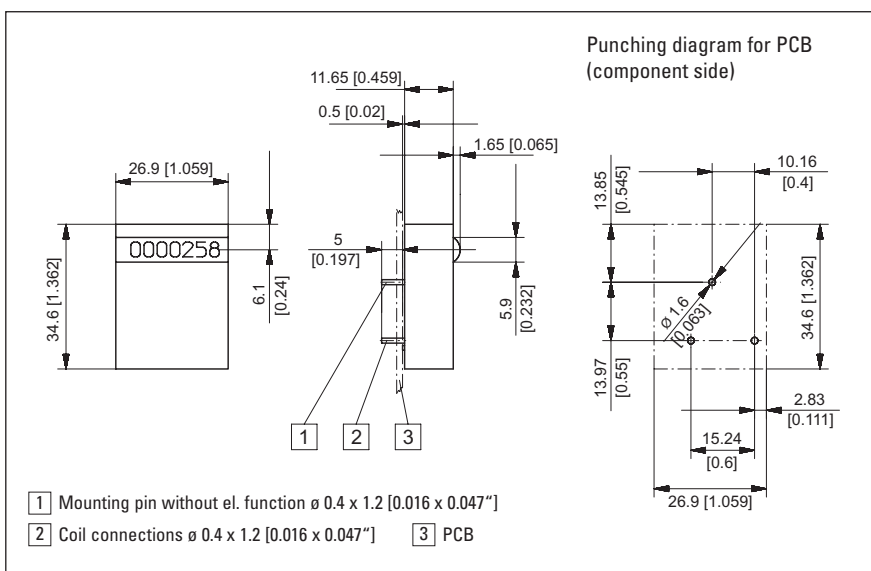

K 06.40 (6-digit)	3 V Art. no.	4.5 V Art. no.	12 V Art. no.	24 V Art. no.
DC (10 Imp/s)	1.120.401.006	1.120.401.008	1.120.401.012	
DC (25 Imp/s)			1.120.401.032	1.120.401.033

Colour of housing blue (zinc-plated)

K 07.40 (7-digit)	3 V Art. no.	4.5 V Art. no.	12 V Art. no.	24 V Art. no.
DC (10 Imp/s)	1.130.401.006	1.130.401.008*	1.130.401.012	
DC (25 Imp/s)			1.130.401.032	1.130.401.033

## Type K 04.50 and K 05.50

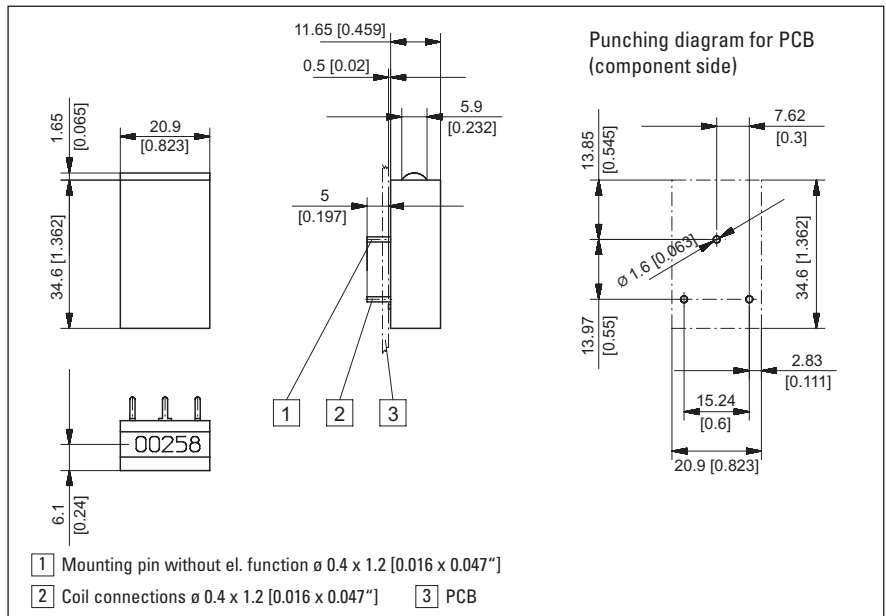

<b>K 04.50</b> (4-digit)	3 V Art. no.	4.5 V Art. no.	12 V Art. no.	24 V Art. no.
DC (10 Imp/s)	1.100.501.006	1.100.501.008	1.100.501.012	1.100.501.418
DC (25 Imp/s)			1.100.501.032	1.100.501.033

Colour of housing blue (zinc-plated)

<b>K 05.50</b> (5-digit)	3 V Art. no.	4.5 V Art. no.	12 V Art. no.	24 V Art. no.
DC (10 Imp/s)	1.110.501.006	1.110.501.008	1.110.501.012	1.110.501.418
DC (25 Imp/s)			1.110.501.032	1.110.501.033

## Type K 06.50 and K 07.50

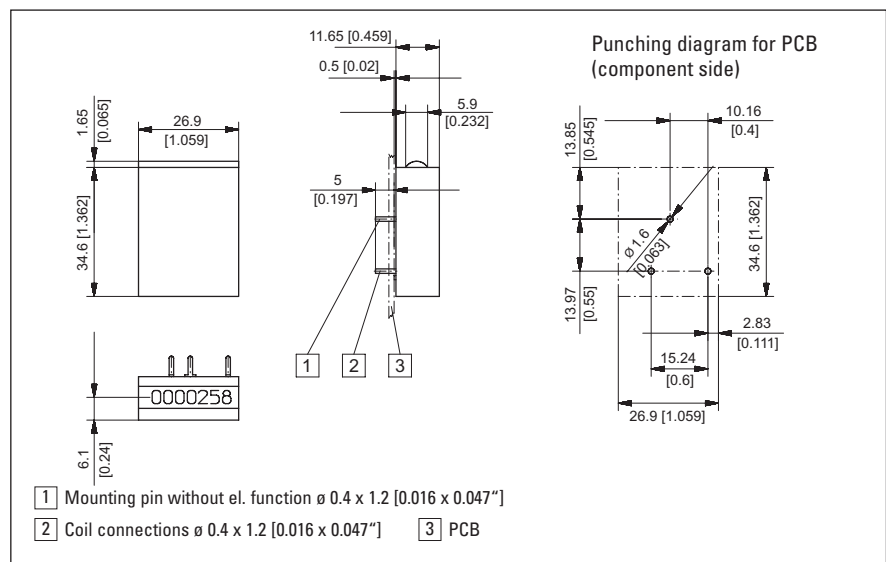

<b>K 06.50</b> (6-digit)	3 V Art. no.	4.5 V Art. no.	12 V Art. no.	24 V Art. no.
DC (10 Imp/s)	1.120.501.006	1.120.501.008	1.120.501.012	1.120.501.418
DC (25 Imp/s)			1.120.501.032	1.120.501.033

Colour of housing blue (zinc-plated)

<b>K 07.50</b> (7-digit)	3 V Art. no.	4.5 V Art. no.	12 V Art. no.	24 V Art. no.
DC (10 Imp/s)	1.130.501.006	1.130.501.008	1.130.501.012	1.130.501.418
DC (25 Imp/s)			1.130.501.032	1.130.501.033

## Type K 04.80 and K 05.80

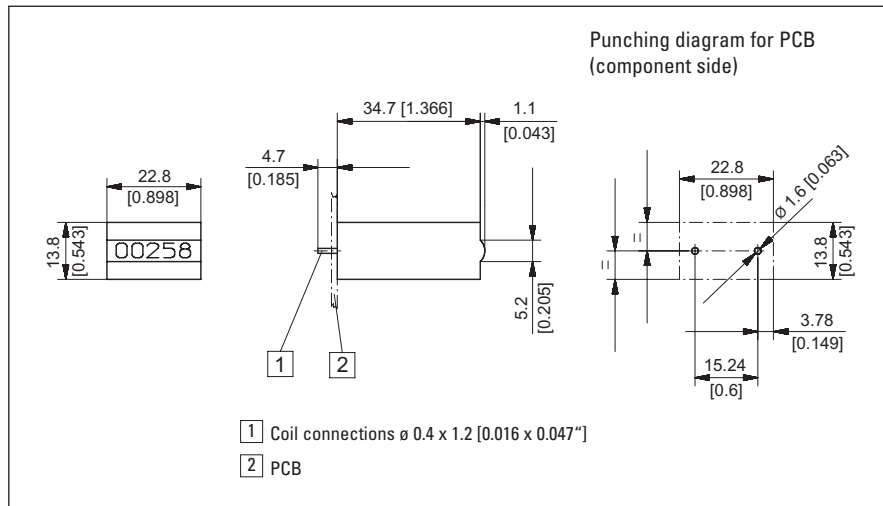

K 04.80 (4-digit)	3 V Art. no.	4.5 V Art. no.	12 V Art. no.	24 V Art. no.
DC (10 Imp/s)	1.100.800.006	1.100.800.008	1.100.800.012	1.100.800.418
DC (25 Imp/s)			1.100.800.032	1.100.800.033

K 05.80 (5-digit)	3 V Art. no.	4.5 V Art. no.	12 V Art. no.	24 V Art. no.
DC (10 Imp/s)	1.110.800.006	1.110.800.008	1.110.800.012	1.110.800.418
DC (25 Imp/s)			1.110.800.032	1.110.800.033

## Type K 06.80 and K 07.80

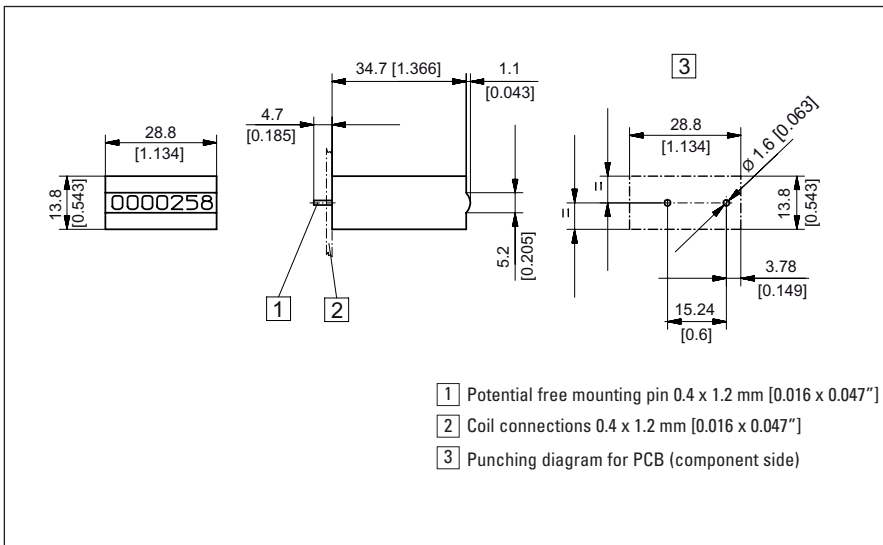

K 06.80 (6-digit)	3 V Art. no.	4.5 V Art. no.	12 V Art. no.	24 V Art. no.	115 V Art. no.	230 V Art. no.
DC (10 Imp/s)	1.120.800.006	1.120.800.008	1.120.800.012	1.120.800.418		
DC (25 Imp/s)			1.120.800.032	1.120.800.033		
AC (10 Imp/s)				1.120.800.051	1.120.800.054	1.120.800.056

K 07.80 (7-digit)	3 V Art. no.	4.5 V Art. no.	12 V Art. no.	24 V Art. no.	115 V Art. no.	230 V Art. no.
DC (10 Imp/s)	1.130.800.006	1.130.800.008	1.130.800.012	1.130.800.418		
DC (25 Imp/s)			1.130.800.032*	1.130.800.033		
AC (10 Imp/s)				1.130.800.051	1.130.800.054	1.130.800.056



## AK 05.00

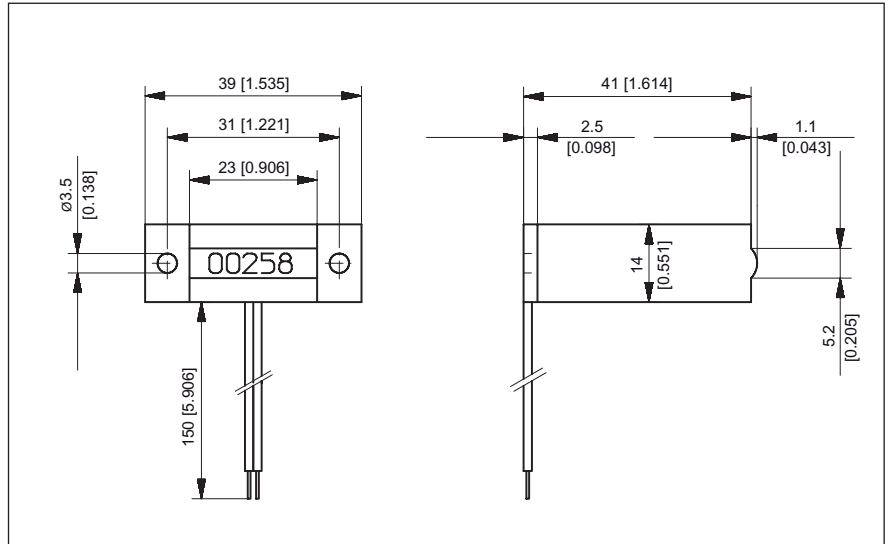

AK 05.00	3 V	4.5 V	12 V	24 V	115 V	230 V
(5-digit)	Art. no.	Art. no.	Art. no.	Art. no.	Art. no.	Art. no.
DC (10 Imp/s)	1.110.000.006	1.110.000.008	1.110.000.012	1.110.000.418		
DC (25 Imp/s)			1.110.000.032	1.110.000.033		
AC (10 Imp/s)				1.110.000.051	1.110.000.054	1.110.000.056

## Type AK 06.00 and AK 07.00

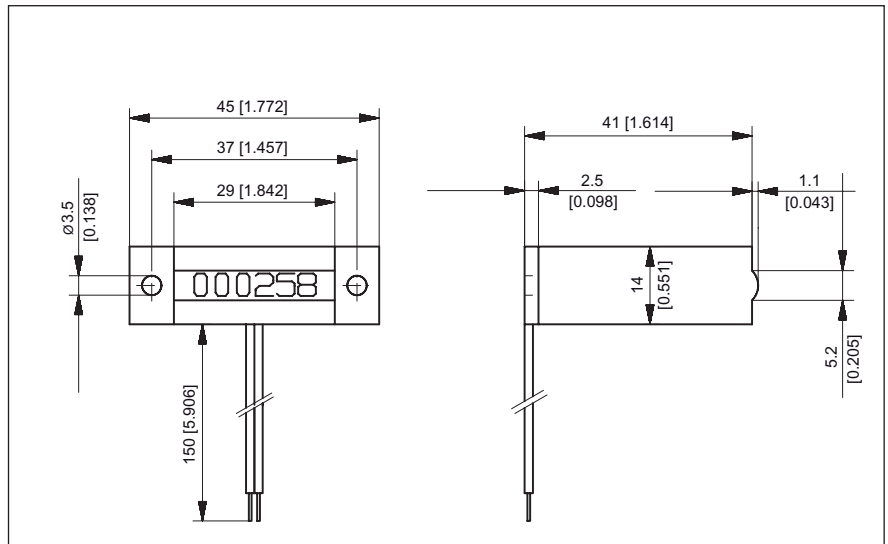

AK 06.00	3 V	4.5 V	12 V	24 V	115 V	230 V
(6-digit)	Art. no.	Art. no.	Art. no.	Art. no.	Art. no.	Art. no.
DC (10 Imp/s)	1.120.000.006	1.120.000.008	1.120.000.012	1.120.000.418		
DC (25 Imp/s)			1.120.000.032	1.120.000.033		
AC (10 Imp/s)				1.120.000.051	1.120.000.054	1.120.000.056

AK 07.00	3 V	4.5 V	12 V	24 V	115 V	230 V
(7-digit)	Art. no.	Art. no.	Art. no.	Art. no.	Art. no.	Art. no.
DC (10 Imp/s)	1.130.000.006	1.130.000.008	1.130.000.012	1.130.000.418		
DC (25 Imp/s)			1.130.000.032	1.130.000.033		
AC (10 Imp/s)				1.130.000.051	1.130.000.054	1.130.000.056

## Type K 06.90 and K 07.90

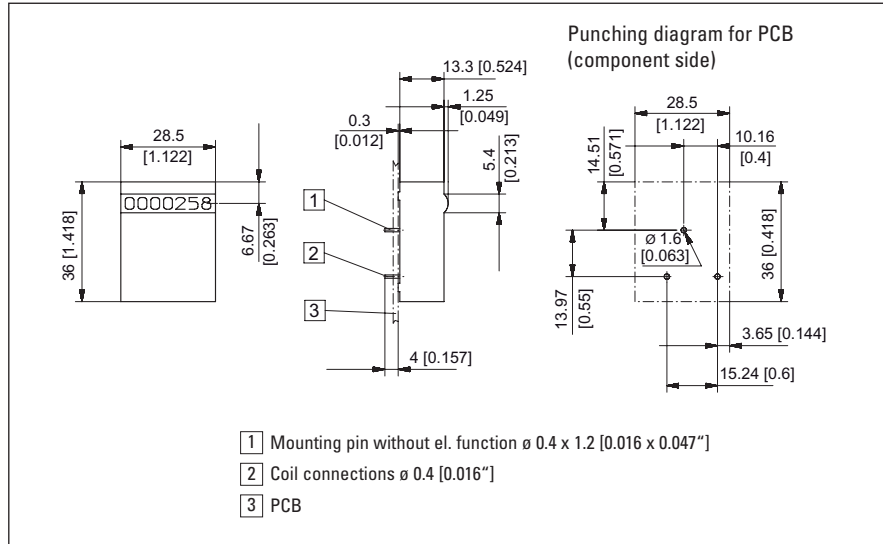

<b>K 06.90</b>	3 V	4.5 V	12 V	24 V	115 V	230 V
(6-digit)	Art. no.	Art. no.	Art. no.	Art. no.	Art. no.	Art. no.
DC (10 Imp/s)	1.120.900.006	1.120.900.008	1.120.900.012	1.120.900.418		
DC (25 Imp/s)			1.120.900.032	1.120.900.033		
AC (10 Imp/s)				1.120.900.051	1.120.900.054	1.120.900.056

<b>K 07.90</b>	3 V	4.5 V	12 V	24 V	115 V	230 V
(7-digit)	Art. no.	Art. no.	Art. no.	Art. no.	Art. no.	Art. no.
DC (10 Imp/s)	1.130.900.006	1.130.900.008	1.130.900.012*	1.130.900.418		
DC (25 Imp/s)			1.130.900.032	1.130.900.033		
AC (10 Imp/s)				1.130.900.051	1.130.900.054	1.130.900.056

\*standard stock model

## Type K 06.92 and K 07.92

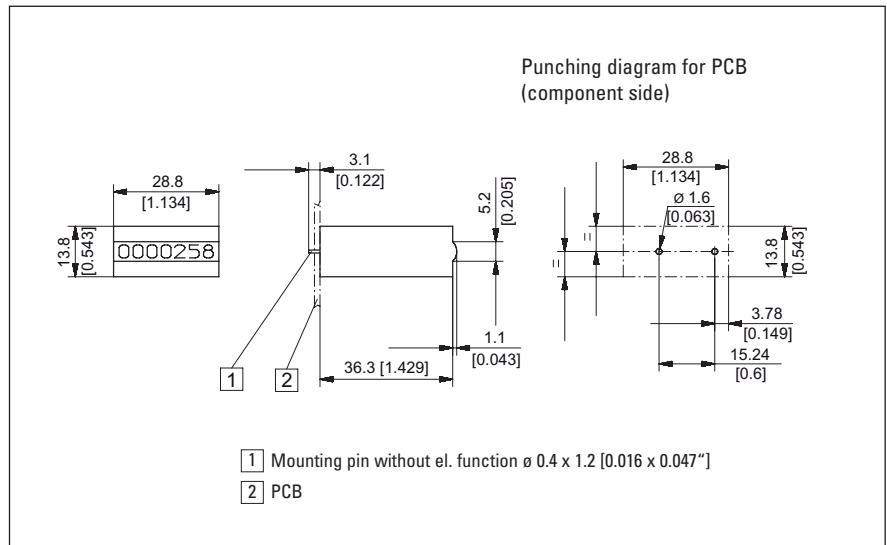

Display counters

<b>K 06.92</b> (6-digit)	3 V Art. no.	4.5 V Art. no.	12 V Art. no.	24 V Art. no.	115 V Art. no.	230 V Art. no.
DC (10 Imp/s)	1.120.920.006	1.120.920.008	1.120.920.012			
DC (25 Imp/s)			1.120.920.032	1.120.920.033		
AC (10 Imp/s)				1.120.920.051	1.120.920.054	1.120.920.056

<b>K 07.92</b> (7-digit)	3 V Art. no.	4.5 V Art. no.	12 V Art. no.	24 V Art. no.	115 V Art. no.	230 V Art. no.
DC (10 Imp/s)	1.130.920.006	1.130.920.008	1.130.920.012			
DC (25 Imp/s)			1.130.920.032	1.130.920.033		
AC (10 Imp/s)				1.130.920.051	1.130.920.054	1.130.920.056

## Totaliser SK 06/SK 07 for Rail mounting



- 6- and 7-digit micro-totaliser
- Rail mounting to EN 50 022
- Base mount counter
- High shock resistance
- Low power consumption
- Small dimensions
- Large optical figures
- Stores value also at power failure
- Long service life
- certified (UL Underwriters Laboratories Inc.)

**Applications:**  
general event counting

### Technical data:

Electrical connection:	clamp terminal for cable diameter up to 2.5 mm <sup>2</sup> , [1612.9 square inch] tightening torque max. 0.8 Nm	Ambient temperature:	-10 ... +60 °C [14 ... 140 °F]
Power consumption: (at 20 °C)	at 10 Imp/s (type 0): approx. 50 mW at 25 Imp/s (type 1): approx. 250 mW at 10 Imp/s (type a0): approx. 800 mVA	Mounting position:	number of wheel view horizontal (other on request)
Rated voltage:	type 0: 1.5/3/4.5/5/6/12 V DC -10 % +20 % type 1: 3/4.5/5/6/12/24 V DC ± 10 % type a0: 12/24/115/230 V AC ± 10 %	Operating life:	> 50 x 10 <sup>6</sup> pulses
Counting frequency:	max. 10 and 25 Imp/s	Protection:	IP 50 front side
Pulse duration:	at 10 Imp/s (type 0 and a0): min. 50 ms at 25 Imp/s (type 1): min. 20 ms	UL-certified:	File E43429
Cycle duration factor:	100 %	Housing:	Plastic black PC
Number of digits:	6 and 7	Weight:	55 g [1.94 oz]
Counting system:	adding	Options:	- Electrical connection: Flat pin 0.8 x 6.3 mm [0.032 x 0.248] and push on connectors Art. no.: 1.1X2.X01.XXX.011
Height of figures:	SK 06: 1.7 x 4 mm [0.067 x 0.158"] optical SK 07: 1.2 x 4 mm [0.047 x 0.158"] optical		- Different voltages - Different digit colours - Different temperature range depends on type
Colour of figures:	white on black		-30 ... +85 °C, -20 ... +70 °C [-22 ... 185 °F, -4 ... 158 °F]
Reset:	no		

### Series:

Type	No. of digits	Height of digits	Width of figures	Description
SK 06.1	6	4 mm	1.7 mm [0.067"]	Base mounting
SK 07.1	7	4 mm	1.2 mm [0.047"]	and rail mounting

### Order code:

- Article number
- For options please give exact counter type, voltage and options e.g.  
SK 06.1.9 V DC/0 temperature range  
-20 ... +70 °C [-4 ... 158 °F]

## Type SK 06.1

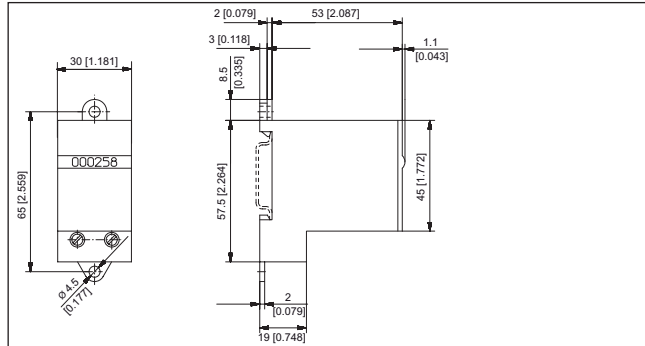

SK 06.1 (6-digit)	12 V Art. no.	24 V Art. no.	115 V Art. no.	230 V Art. no.
DC (10 Imp/s)	1.122.101.012			
DC (25 Imp/s)	1.122.101.032	1.122.101.033		
AC (10 Imp/s)		1.122.101.051	1.122.101.054	1.122.101.056

## Type SK 07.1

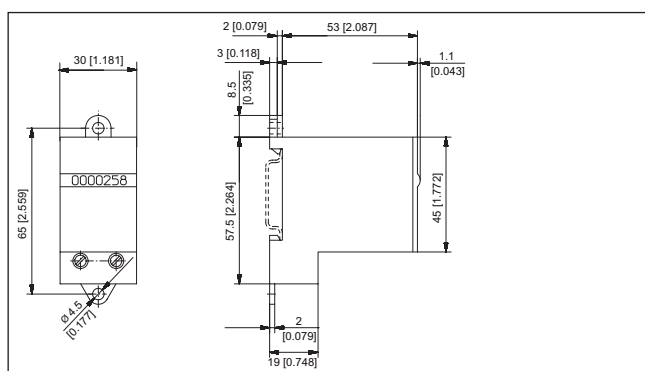

SK 07.1 (7-digit)	12 V Art. no.	24 V Art. no.	115 V Art. no.	230 V Art. no.
DC (10 Imp/s)	1.132.101.012*	1.132.101.013*		
DC (25 Imp/s)	1.132.101.032	1.132.101.033*		
AC (10 Imp/s)		1.132.101.051*	1.132.101.054*	1.132.101.056*

\*standard stock model

## Miniature pulse counter W 15



- 5-digit miniature pulse counter, adding with manual reset
- Power consumption min. 130 mW
- Suitable for battery operation
- Long operating life (50 Mio. pulses)
- Available for all DC and AC voltages
- DIN housing 24 mm x 48 mm [0.945 x 1.89"] available

### Applications:

self powered device,  
battery operation  
vending machines, automatic  
message systems,  
general counting systems



### Technical data:

Electrical connection:	standard:	flying leads AWG 22, approx. 150 mm [5.906"] long
	options:	pins $\varnothing$ 1.5 mm [0.059"] with push on connectors
Rated voltage:	type 05:	1.5/3/4.5/5/6/12 V DC +15 % -5 %
	type 0:	12/24/48/115/185 V DC $\pm$ 10 %
	type a0:	12/24/48/115/230 V AC $\pm$ 10 %
Cycle duration factor:		100 %
Height of figures:		approx. 1.7 x 4 mm [0.067 x 0.158"]
Colour of figures:		white on black
Shafts:		stainless steel
Ambient temperature:		-10 ... +50 °C [14 ... 122 °F]
Mounting position:		any
Operating life:		> 50 x 10 <sup>6</sup> pulses
Weight:		AC 52 g, DC 62 g [AC 1.834 oz, DC 2.187 oz]

### Options:

- Electrical Connection:  
instead of flying leads, pin  $\varnothing$  1.5 mm [0.059"]  
with push on connectors  
Art. no.: 1.151.X1X.XXX
- with flat pin 0.8 x 2.8 mm [0.032 x 0.11"] and  
flat push on connectors  
Art. no.: 1.159.X1X.XXX
- ...with flat pin 0.8 x 6.3 [0.032 x 0.248"]  
...Art-No.: 1.155.XXX.XXX
- ...with screw terminal  
... Art. no: 1.154.XXX.XXX
- Different temperature range on request
- Colour of housing:  
light grey: Art. no.: X.XXX.XX0.XXX  
black: Art. no.: X.XXX.XX1.XXX  
availability see table

### Series:

Type	Description
W 15.01	Housing without front panel, rear screw mount
W 15.21	Panel mount with spring clip 31 x 20 mm [1.221 x 0.788"]
W 15.21.56	Built in counter with spring, dimension 31 x 20 mm [1.221 x 0.788"]
W 15.51	DIN housing 24 x 48, dimension 22 x 45 mm [0.866 x 1.772"]
W 15.91	Built in counter with spring, dimension 37.5 x 23.5 mm [1.477 x 0.925"]
AW 15.01	Base mount with two mounting holes

### Counting mechanism:

Voltage	Model	Max. pulse speed	Pulse on time	Pulse interval min.	Power consumpt. approx.	Residual ripple voltage max.
V DC	05	8	50 ms	75 ms	130 mW	5 %
	0	10	50 ms	50 ms	0.5 W ( $\leq$ 115 V) 1 W (185 V)	48 %
V AC	a0	10	50 ms	50 ms	0.75 VA ( $\leq$ 115 V) 1.5 VA (230 V)	

### Order code:

- Article number
- For special voltages, please give type, voltage, kind of voltage and series e.g.  
W 15.21, 4.5 V DC/0, black.

## Type W 15.01

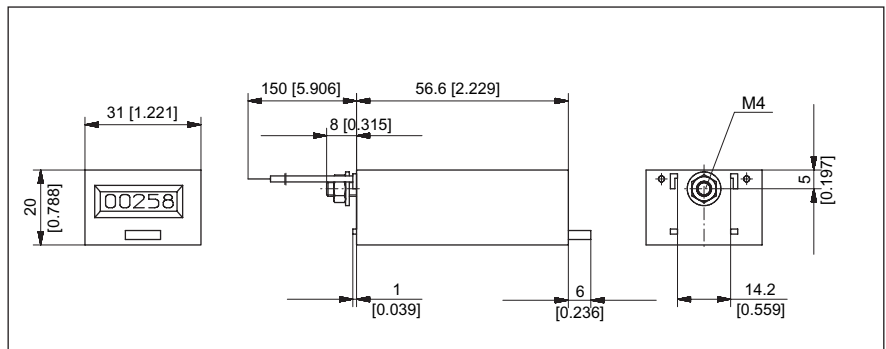

W 15.01 (5-digit)	12 V Art. no.	24 V Art. no.	115 V Art. no.	230 V Art. no.
DC (8 Imp/s)	1.150.010.049	1.150.010.050		
DC (10 Imp/s)	1.150.010.012	1.150.010.013		
AC (10 Imp/s)		1.150.010.051	1.150.010.054	1.150.010.056

Colour of housing black  
Art. no. 1.150.011.XXX

## Type W 15.21

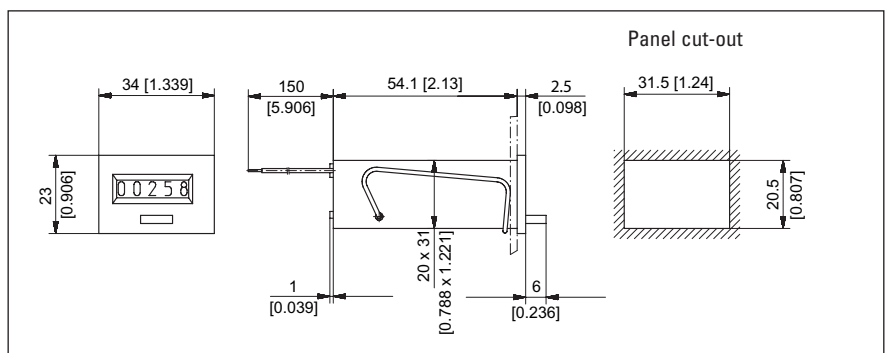

W 15.21 (5-digit)	12 V Art. no.	24 V Art. no.	115 V Art. no.	230 V Art. no.
DC (8 Imp/s)	1.150.210.049	1.150.210.050		
DC (10 Imp/s)	1.150.210.012	1.150.210.013*		
AC (10 Imp/s)		1.150.210.051*	1.150.210.054	1.150.210.056*

Colour of housing black:  
Art. no. 1.150.211.XXX

## Type W 15.21.56

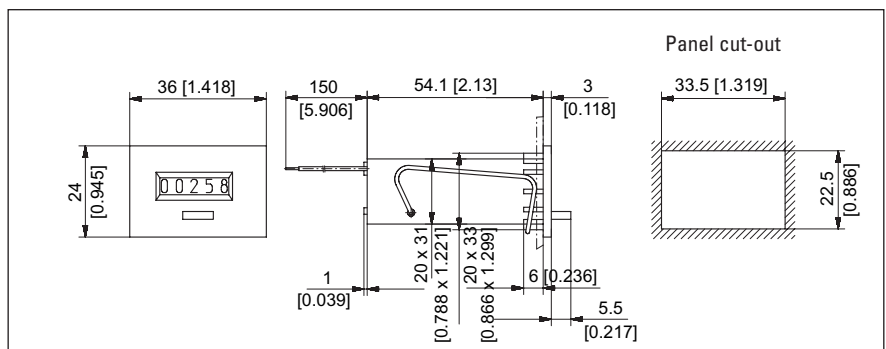

W 15.21.56 (5-digit)	12 V Art. no.	24 V Art. no.	115 V Art. no.	230 V Art. no.
DC (8 Imp/s)	1.150.210.049.056	1.150.210.050.056		
DC (10 Imp/s)	1.150.210.012.056	1.150.210.013.056		
AC (10 Imp/s)		1.150.210.051.056	1.150.210.054.056	1.150.210.056.056

Colour of housing black:  
Art. no. 1.150.211.XXX.056

## Type W 15.91

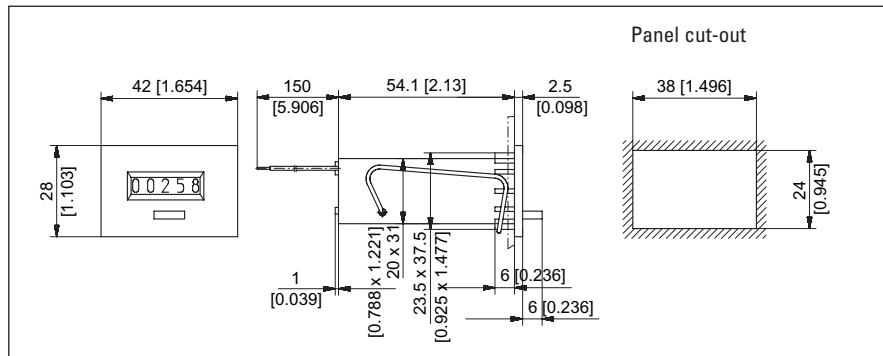

W 15.91 (5-digit)	12 V Art. no.	24 V Art. no.	115 V Art. no.	230 V Art. no.
DC (8 Imp/s)	1.150.910.049	1.150.910.050		
DC (10 Imp/s)	1.150.910.012	1.150.910.013		
AC (10 Imp/s)		1.150.910.051	1.150.910.054	1.150.910.056

Colour of housing black:  
Art. no. 1.150.911.XXX

## Type AW 15.01

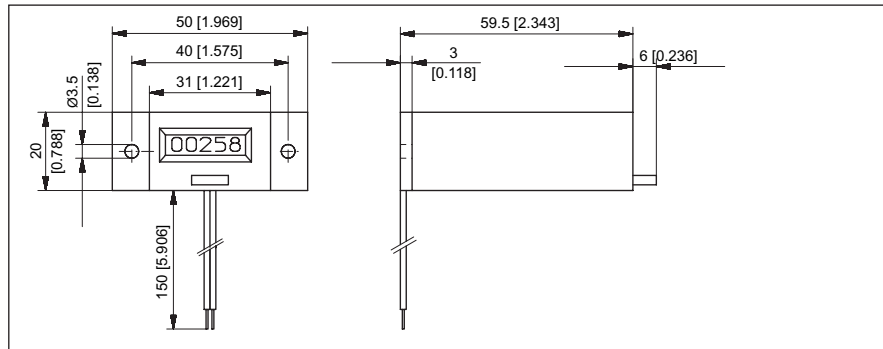

AW 15.01 (5-digit)	12 V Art. no.	24 V Art. no.	115 V Art. no.	230 V Art. no.
DC (8 Imp/s)	1.152.011.049	1.152.011.050		
DC (10 Imp/s)	1.152.011.012	1.152.011.013		
AC (10 Imp/s)		1.152.011.051	1.152.011.054	1.152.011.056

Colour of housing black

## Type W 15.51

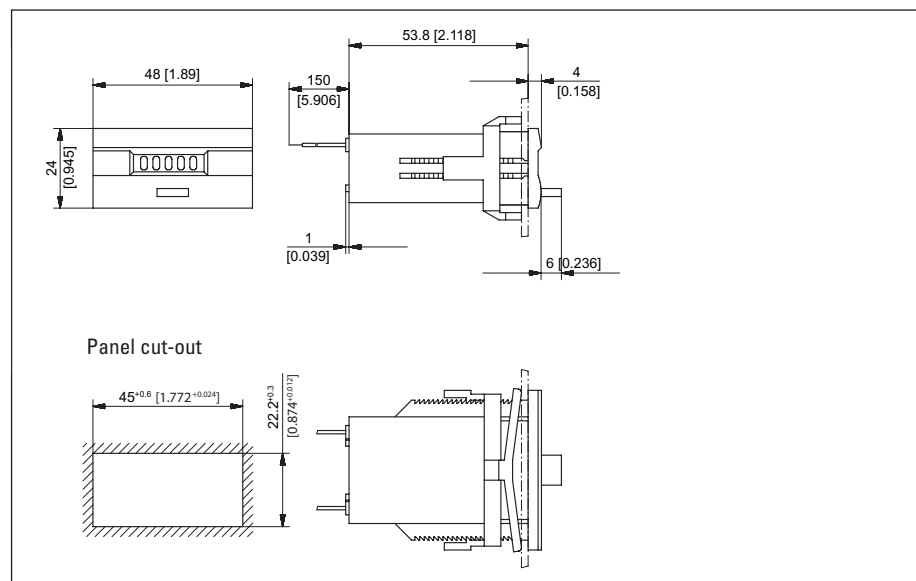

W 15.51 (5-digit)	12 V Art. no.	24 V Art. no.	115 V Art. no.	230 V Art. no.
DC (8 Imp/s)	1.150.510.049.550	1.150.510.050.550		
DC (10 Imp/s)	1.150.510.012.550*	1.150.510.013.550*		
AC (10 Imp/s)		1.150.510.051.550	1.150.510.054.550*	1.150.510.056.550*

Colour of housing anthracite



## Miniature pulse counter W 16/W 17



- 6- or 7-digit miniature pulse counter, without reset
- Power consumption min. 50 mW
- Power consumption at version 05 and 50 ms pulse length 2.5 mWs/Pulse
- Long operating life
- For all DC and AC voltages
- Types to DIN dimension 24 mm x 48 mm [0.945 x 1.89"] and many other dimensions e.g. PCB mount
- Protection IP 41

### Applications:

self powered device,  
battery operation  
Vending machines, automatic  
message systems, general  
counting systems

### Technical data:

Electrical connection:	Panel and-surface mount model PCB mounting	Flying leads AWG 22, approx. 150 mm [5.906"] round pin $\varnothing$ 1.6 mm [0.063"]
Rated voltage:	type 05: 1.5/3/4.5/5/6/12 V DC $\pm 15\%$ $-5\%$ type 0: 12/24/48/115/185 V DC $\pm 10\%$ type a0: 24/48/115/230 V AC $\pm 10\%$	
Cycle duration factor:	100 %	
Height of figures:	approx. 1.7 x 4 mm [0.067 x 0.158"]	
Colour of figures:	white on black	
Shaft:	stainless steel	
Ambient temperature:	-10 ... +50 °C [14 ...122 °F]	
Mounting position:	any	
Operating life:	> 50 x 10 <sup>6</sup> pulses	
Weight:	approx. 50 g [1.764 oz]	

### Options:

– Electrical Connection:	counter with pins $\varnothing$ 1.6 mm [0.063"] and push on connectors Art. no.: 1.161.XXX.XXX
	with Flat pin 0.8 x 2.8 mm [0.032 x 0.11"] and push on connectors Art. no.: 1.169.XXX.XXX
	...with Flat pin 0.8 x 6.3 [0.032 x 0.248"] and push on connectors ...Art-No.: 1.165.XXX.XXX
	...with screw terminal ... Art. no: 1.164.XXX.XXX
– Extended temperature range	
– With lens or digit height 5 or 6.3 mm [0.197" or 0.248"] on request	
Colour of housing:	light grey: Art. no.: X.XXX.XX0.XXX black: Art. no.: X.XXX.XX1.XXX availability see table

### Type series:

Type	Housing	Display	Description
W 16.00	Plastic	Small side	Counter without front bezel, rear mounting
W 16.20	Plastic	Small side	Flush mount counter with spring clip, dimension 31 x 20 mm [1.221 x 0.788"]
W 16.20.10	Plastic	Small side	Flush mount counter with spring clip, panel cut-out 33 x 24 mm [1.299 x 0.945"]
W 16.20.31	Plastic	Small side	Flush mount counter with spring clip, panel cut-out 32 x 23 mm [1.26 x 0.906"]
W 16.40	Plastic	Small side	2 two holes at front side
W 16.50	Plastic	Small side	DIN housing 24 x 48 [0.945 x 1.89"], Built in dimension 22 x 45 mm [0.866 x 1.772"]
W 16.60	Steel	Large side	PCB counter
W 16.70	Steel	Small side	PCB counter
W 16.80	Plastic	Small side	PCB counter
W 16.90	Plastic	Small side	Flush mount counter with spring , dimension 37.5 x 23.5 [1.477 x 0.925"]
AW 16.00	Plastic	Small side	Base mount counter
AW 16.80	Plastic	Small side	Base mount counter
AW 16.81	Plastic	Small side	Base mount counter
W 17.50	Plastic	Small side	DIN housing with spring 24 x 48 mm [0.945 x 1.89"], Panel cut-out 22 x 45 mm [0.866 x 1.772"]
W 17.80	Plastic	Small side	PCB counter
W 17.90	Plastic	Small side	Panel counter with spring, Panel cut-out 37.5 x 23.5 mm [1.477 x 0.925"]

### Counting mechanism:

Voltage	Model	max. Pulse-speed	Pulse on time	Pulse interval min.	Power consumpt. approx.	Residual ripple voltage max.
DC	05	8	50 ms	75 ms	50 mW	5 %
	0	10	50 ms	50 ms	0.5 W ( $\leq$ 115 V) 1 W (185 V)	48 %
AC	a0	10	50 ms	50 ms	0.75 VA ( $\leq$ 115 V) 1.5 VA (230 V)	

### Order code:

- Article number
- For special voltages, please give type, voltage, kind of voltage and series e.g. W 16.20, 9 V DC, 05, black.

## Type W 16.00

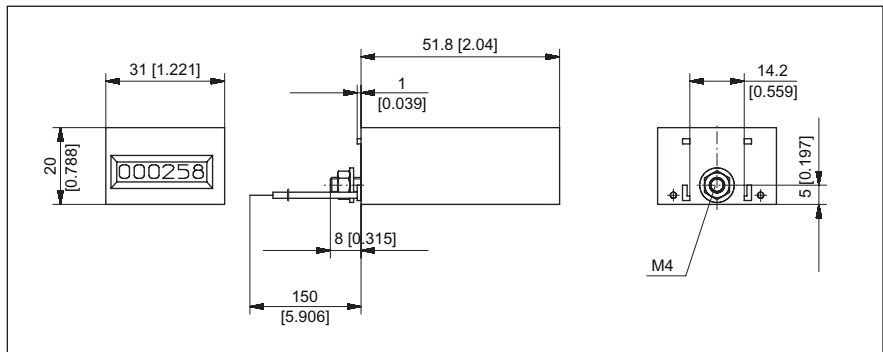

W 16.00 (6-digit)	12 V Art. no.	24 V Art. no.	115 V Art. no.	230 V Art. no.
DC (8 Imp/s)	1.160.000.049	1.160.000.050		
DC (10 Imp/s)	1.160.000.012	1.160.000.013		
AC (10 Imp/s)		1.160.000.051	1.160.000.054	1.160.000.056

Colour of housing black:  
Art. no. 1.160.001.XXX

## Type W 16.20

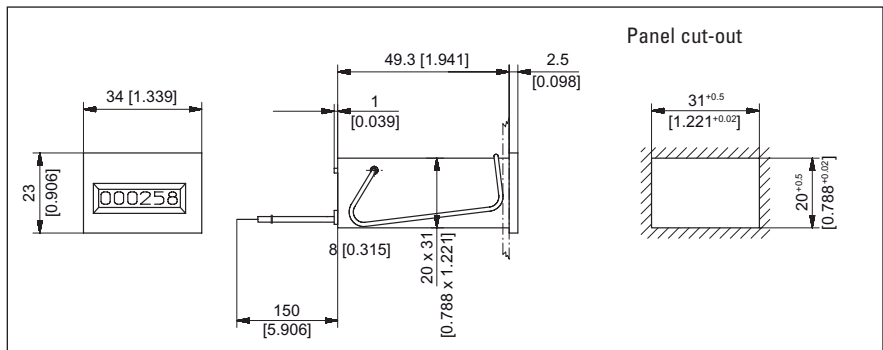

W 16.20 (6-digit)	12 V Art. no.	24 V Art. no.	115 V Art. no.	230 V Art. no.
DC (8 Imp/s)	1.160.200.049	1.160.200.050		
DC (10 Imp/s)	1.160.200.012	1.160.200.013*		
AC (10 Imp/s)		1.160.200.051	1.160.200.054	1.160.200.056*

Colour of housing black:  
Art. no. 1.160.201.XXX

## Type W 16.20.10

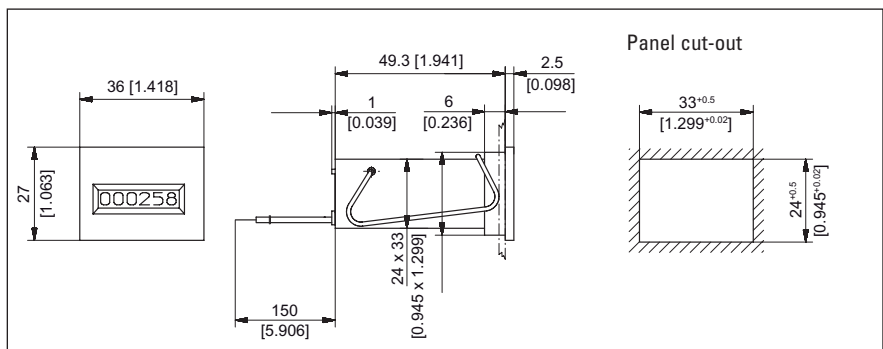

W 16.20.10 (6-digit)	12 V Art. no.	24 V Art. no.	115 V Art. no.	230 V Art. no.
DC (8 Imp/s)	1.168.250.049	1.168.250.050		
DC (10 Imp/s)	1.168.250.012	1.168.250.013		
AC (10 Imp/s)		1.168.250.051	1.168.250.054	1.168.250.056

Colour of housing black:  
Art. no. 1.168.251.XXX

## Type W 16.20.31

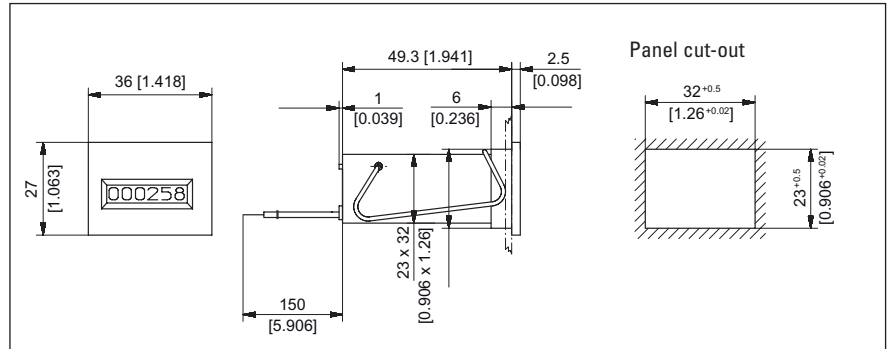

W 16.20.31 (6-digit)	12 V Art. no.	24 V Art. no.	115 V Art. no.	230 V Art. no.
DC (8 Imp/s)	1.168.260.049	1.168.260.050		
DC (10 Imp/s)	1.168.260.012	1.168.260.013		
AC (10 Imp/s)		1.168.260.051	1.168.260.054	1.168.260.056

Colour of housing black:  
Art. no. 1.168.261.XXX

## Type W 16.40

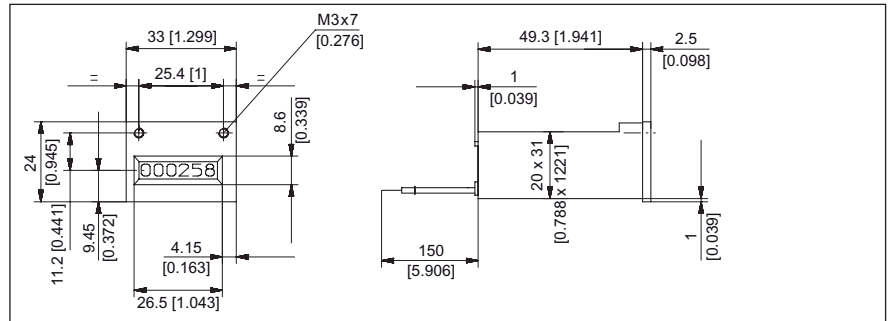

W 16.40 (6-digit)	12 V Art. no.	24 V Art. no.	115 V Art. no.	230 V Art. no.
DC (8 Imp/s)	1.160.401.049	1.160.401.050		
DC (10 Imp/s)	1.160.401.012	1.160.401.013		
AC (10 Imp/s)		1.160.401.051	1.160.401.054	1.160.401.056

Colour of housing black

## Type W 16.50/W17.50

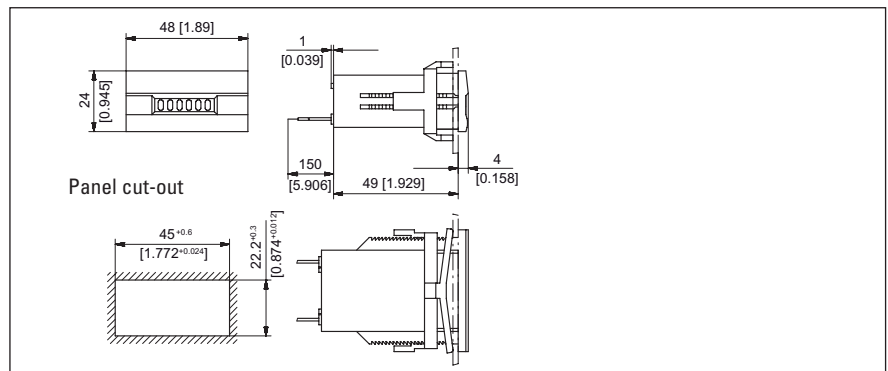

W 16.50 (6-digit)	12 V Art. no.	24 V Art. no.	115 V Art. no.	230 V Art. no.
DC (8 Imp/s)	1.160.500.049.550	1.160.500.050.550		
DC (10 Imp/s)	1.160.500.012.550	1.160.500.013.550		
AC (10 Imp/s)		1.160.500.051.550	1.160.500.054.550	1.160.500.056.550

Colour of housing anthracite

W 17.50 (7-digit)	12 V Art. no.	24 V Art. no.	115 V Art. no.	230 V Art. no.
DC (8 Imp/s)	1.740.500.049.550	1.740.500.050.550		
DC (10 Imp/s)	1.740.500.012.550*	1.740.500.013.550*		
AC (10 Imp/s)		1.740.500.051.550	1.740.500.054.550*	1.740.500.056.550*

## Type W 16.60

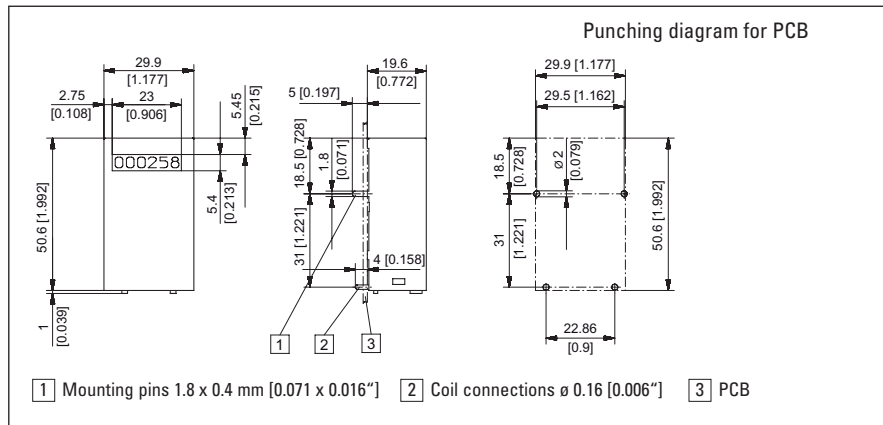

W 16.60 (6-digit)	12 V Art. no.	24 V Art. no.
DC (8 Imp/s)	1.160.601.049	1.160.601.050
DC (10 Imp/s)	1.160.601.012	1.160.601.013

Colour of housing blue (zinc-plated)

## Type W 16.70

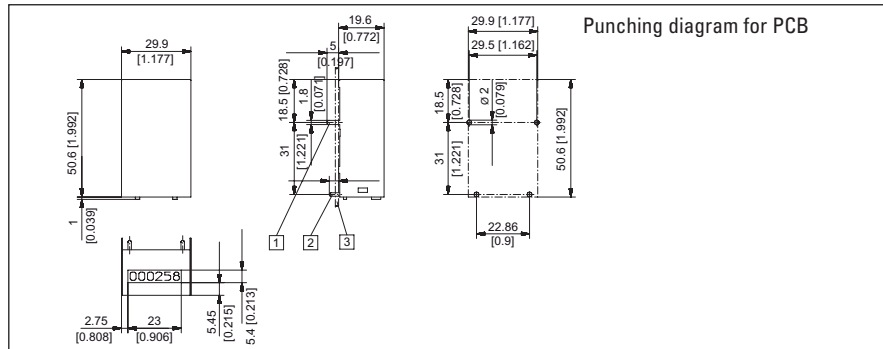

W 16.70 (6-digit)	12 V Art. no.	24 V Art. no.
DC (8 Imp/s)	1.160.701.049	1.160.701.050
DC (10 Imp/s)	1.160.701.012	1.160.701.013

Colour of housing blue (zinc-plated)

## Type W 16.90/W 17.90

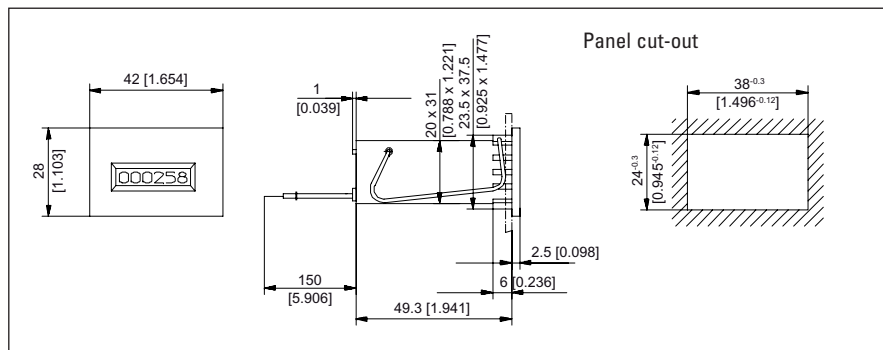

W 16.90 (6-digit)	12 V Art. no.	24 V Art. no.	115 V	230 V
DC (8 Imp/s)	1.160.900.049	1.160.900.050	-	-
DC (10 Imp/s)	1.160.900.012	1.160.900.013	-	-
AC (10 IMP/s)	-	-	1.160.900.054	1.160.900.056

Colour of housing black:  
Art. no. 1.160.901.XXX

W 17.90 (7-digit)	12 V Art. no.	24 V Art. no.	115 V	230 V
DC (8 Imp/s)	1.740.900.049	1.740.900.050	-	-
DC (10 Imp/s)	1.740.900.012	1.740.900.013	-	-
AC (10 IMP/s)	-	-	1.740.900.054	1.740.900.056

Colour of housing black  
not available

## Type W 16.80/W 17.80

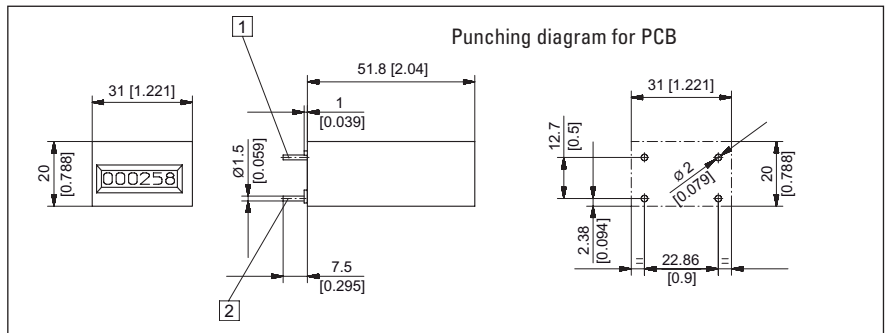

1 Potential free pins 2 Coil connections

W 16.80 (6-digit)	12 V Art. no.	24 V Art. no.	115 V Art. no.	230 V Art. no.
DC (8 Imp/s)	1.160.800.049	1.160.800.050		
DC (10 Imp/s)	1.160.800.012	1.160.800.013		
AC (10 Imp/s)		1.160.800.051	1.160.800.054	1.160.800.056
W 17.80 (7-digit)	12 V Art. no.	24 V Art. no.	115 V Art. no.	230 V Art. no.
DC (10 Imp/s)	1.740.800.012	1.740.800.013		
AC (10 Imp/s)		1.740.800.051	1.740.800.054	1.740.800.056

Colour of housing grey

## Type AW 16.00

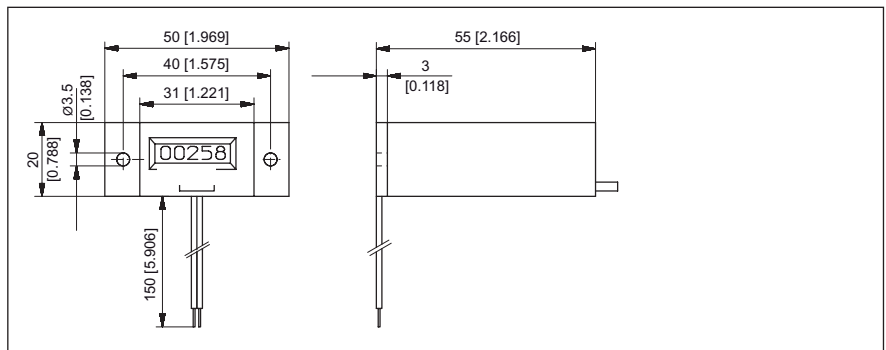

AW 16.00 (6-digit)	12 V Art. no.	24 V Art. no.	115 V Art. no.	230 V Art. no.
DC (8 Imp/s)	1.162.001.049	1.162.001.050		
DC (10 Imp/s)	1.162.001.012	1.162.001.013*		
AC (10 Imp/s)		1.162.001.051	1.162.001.054	1.162.001.056

Colour of housing black

## Type AW 16.80 and AW 16.81

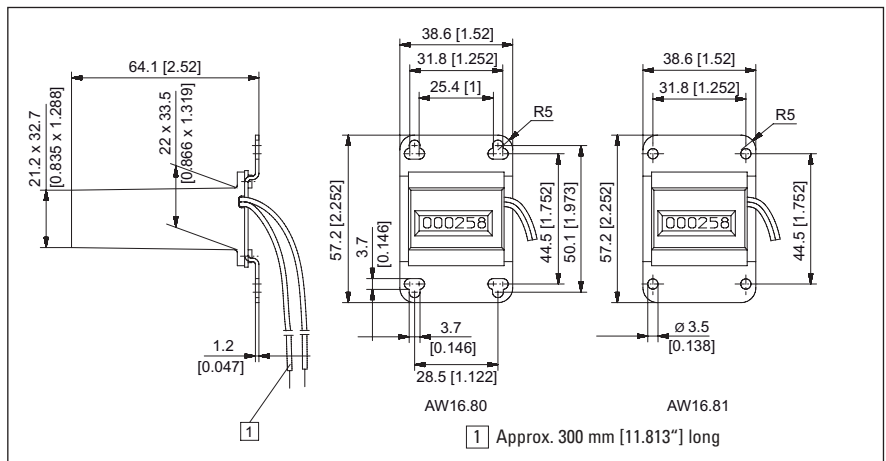

Type	Imp/s	12 V DC Art. no.	24 V DC Art. no.
AW 16.80	10	1.162.800.012	1.162.800.013
AW 16.81	10	1.162.810.012	1.162.810.013

Colour of housing:  
grey glass (Makrolon)

## Totaliser BK 14 and BK 16 with and without reset



- BK 14, 4-digit totaliser with manual reset
- BK 16, 6-digit totaliser without reset
- Very high operating life (200 Mio. pulses)

### Applications:

general counting, time, performance and rate measuring

### Technical data:

Electrical connection:	tin plated round pins $\varnothing$ 1.5 mm [0.059"] with push on connectors
Rated voltage:	type 0/1/a: 12/24/48/115/230 V DC $\pm$ 10 % 24/48/115/230 V AC $\pm$ 10 %
Colour of counter:	grey
Height of figures:	approx. 2 x 4 mm [0.079 x 0.158"]
Colour of figures:	white on black
Shaft:	stainless steel
Mounting position:	any
Operating life:	approx. 200 x 10 <sup>6</sup> pulses
Weight:	without reset 66 g [2.328 oz] with reset 70 g [2.469 oz]

Test voltage:	2000 V ~ effective, according to VDE 0435	
Shock resistance:	3 g at	10 Hz
	6 g at	15 Hz
	10 g	20 ... 300 Hz

### Options:

- Key-Locking zero-reset special key (Order code "vs", e.g. BK 14.11 vs)
- Housing Colour black
- Higher counting speed
- Also with flying leads

### Series:

6 digit without reset	4 digit with	Description
BK 16.10	BK 14.11	flush mount with 2 mounting holes
BK 16.20	BK 14.21	flush mount with spring clip

### Order code:

- Article number
- At different voltages, please give type, voltage, kind of voltage and series e.g. BK 14.21, 12 V AC, type a.

### Counting mechanism:

Voltage	Model	Max. pulse freq.	Min. pulse on time	Min. pulse interval	Pulse ratio	On-time	Power consumption	Max. ripple voltage	Ambient temperature °C [°F]
V DC	0	10/sec	60 ms	40 ms	3:2	100 %	approx. 1W	48 %	-10 ... [14 °F]
	1	25/sec	24 ms	16 ms	3:2	100 %	approx. 2W	48 %	+60 [140 °F]
V AC	a	18/sec	22.2 ms	33.3 ms	2:3	100%	approx. 2.9VA		-10 ... + 55 [14 ... 131 °F]

### Type BK 16.10

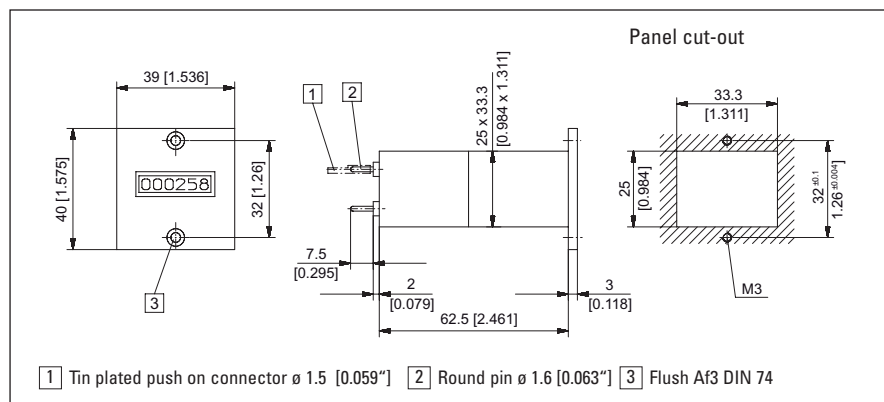

BK 16.10 (6-digit)	12 V	24 V	115 V	230 V
	Art. no.	Art. no.	Art. no.	Art. no.
DC (10 Imp/s)	1.190.100.012	1.190.100.013		
DC (25 Imp/s)	1.190.100.032	1.190.100.033		
AC (18 Imp/s)		1.190.100.061	1.190.100.064	1.190.100.066

## Type BK 16.20

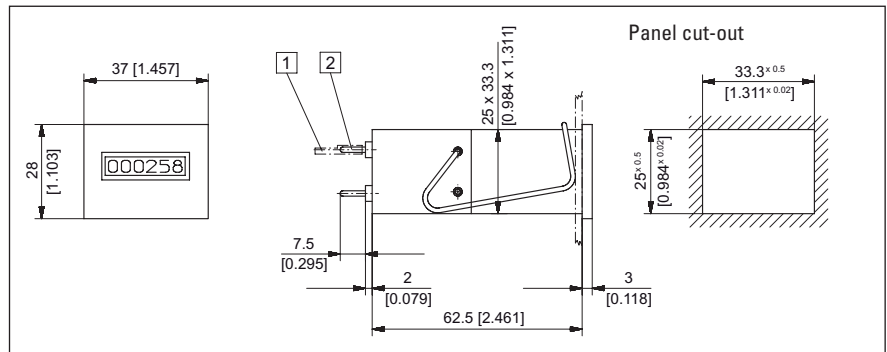

- 1 Tin plated push on connector  $\varnothing$  1.5 [0.059"]
- 2 Round pin  $\varnothing$  1.5 [0.059"] tin

BK 16.20 (6-digit)	12 V Art. no.	24 V Art. no.	115 V Art. no.	230 V Art. no.
DC (10 Imp/s)	1.190.200.012	1.190.200.013		
DC (25 Imp/s)	1.190.200.032	1.190.200.033		
AC (18 Imp/s)		1.190.200.061	1.190.200.064	1.190.200.066

## Type BK 14.11

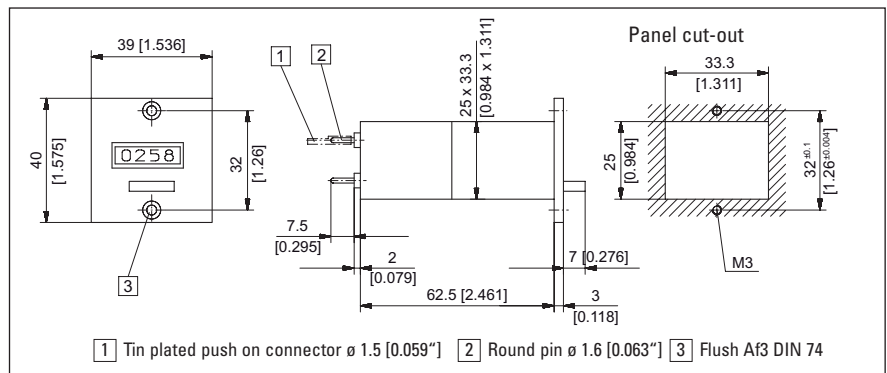

- 1 Tin plated push on connector  $\varnothing$  1.5 [0.059"]
- 2 Round pin  $\varnothing$  1.6 [0.063"]
- 3 Flush Af3 DIN 74

BK 14.11 (4-digit)	12 V Art. no.	24 V Art. no.	115 V Art. no.	230 V Art. no.
DC (10 Imp/s)	1.180.110.012	1.180.110.013*		
DC (25 Imp/s)	1.180.110.032	1.180.110.033		
AC (18 Imp/s)		1.180.110.061	1.180.110.064	1.180.110.066

## Type BK 14.21

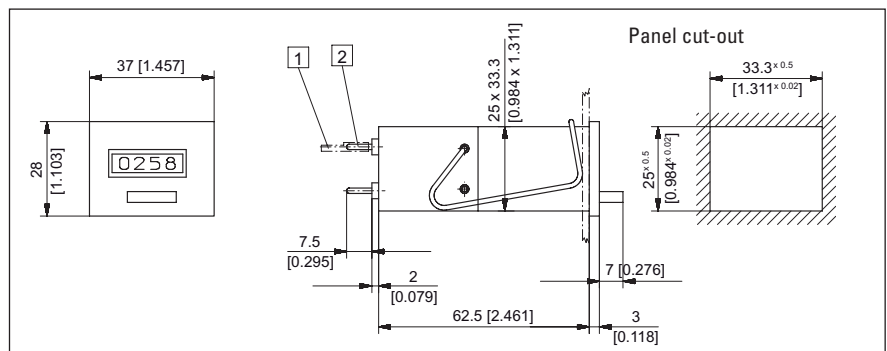

BK 14.21 (4-digit)	12 V Art. no.	24 V Art. no.	115 V Art. no.	230 V Art. no.
DC (10 Imp/s)	1.180.210.012	1.180.210.013*		
DC (25 Imp/s)	1.180.210.032	1.180.210.033		
AC (18 Imp/s)		1.180.210.061	1.180.210.064	1.180.210.066*

## Totaliser B 15 - B 18 with and without reset



- B 15..1 and B 16..1, 5 resp. 6-digit totaliser with manual reset
- B 15..0, B 16..0 and B 18..0, 5, 6 and 8-digit Totaliser without reset
- Counters without front panel fit into front frames F1B and F2B. The latter can accommodate combination of count with dimensions of 50 x 50 mm [1.969 x 1.969"]
- Combined with preset counter of Type series BVa and HVa.
- Very high operating life (200 Mio. pulses)

### Applications:

counting number of pieces, events, periods

### Technical data:

Electrical connection:	pin $\varnothing$ 1.6 mm [0.063] with push on connector (count mechanism) for flying leads 0.5 ... 1.0 mm <sup>2</sup> [322.58 x 645.16 square inch] Flat pin 0.8x2.8 mm [0.315 x 0.11"] (socket box)		
Rated voltage:	type 0/1/a: 12/24/48/115/230 V DC $\pm$ 10 % 24/48/115/230 V AC $\pm$ 10 %		
Colour of counter:	grey		
Height of figures:	B 15	2.4 x 4.5 mm [0.094 x 0.177"]	
	B 16	2 x 4.5 mm [0.079 x 0.177"]	
	B 18	2 x 4 mm [0.079 x 0.158"]	
Colour of figures:	white on black		
Shaft:	stainless steel		
Mounting position:	any		
Operating life:	approx. 200 x 10 <sup>6</sup> pulses		
Weight:	without reset	81 g [2.857 oz]	
	with reset	83 g [2.928 oz]	
	socket box	14 g [0.494 oz]	
Test voltage:	2 000 V ~ effective, according to VDE 0435		
<b>Accessories:</b>			
Transparent cover:	Protection IP 55 according to DIN 400050 from front side when cover is closed. Gasket: oil and gasoline resistant synthetic rubber especially suitable for acids and electrolytes, good resistance to ageing		

Options:	– Colour of housing: black (For Art. no. ref. to type)
	– Electr. connection at counter: flat pins 0.8 x 2.8 mm [0.315 x 1.102"] with push on connectors Art. no. 1.2X7.XXX.XXX Screw terminal 1.2.XXX.XXX.023
	– Connection with flying leads
	– Extended temperature range
	– Key locking zero reset
	– Knob locking with transparent cover a.) Counter with front bezel size No. 3 Art. no. 1.2X0.7XX.XXX b.) Counter with front frame F 1 Art. no. 1.2X1.7XX.XXX
	– Knob locking with transparent cover a.) Counter with front bezel size No. 3 Art. no. 1.2X0.8XX.XXX.XXX
	– Flexible sealing cover K 1 (IP 54) a.) Counter with front bezel size No. 3 Art. no. 1.2X0.6XX.XXX
	Key for reset: G50 265

### Series:

without reset		with reset		Description:
6-digit	8-digit	5-digit	6-digit	
16.00	B 18.00	–	B 16.01	without front bezel, rear mounting plugs into socket box 945.2
B 16.10	B 18.10	B 15.11	B 16.11	panel mount front bezel size No. 1, 2 mounting holes
B 16.20	B 18.20	B 15.21	B 16.21	panel mount with spring clip fastening
B 16.30	B 18.30	–	B 16.31	panel mount front bezel size No. 3, 2 mounting holes
F1 B 16.00	F1 B 18.00	–	F1 B 16.01	panel mount, plugs into frame F1 with socket box 945.2
			Dv B 16.31	panel mount front bezel size No. 3, knob locking transparent cover
			F1 Dv B 16.01	panel mount front frame F1, knob locking transparent cover
			Dvs B 16.31	panel mount, front bezel size No. 3, key locking with transparent cover
			F1 Dvs B 16.01	panel mount front frame F1, key locking transparent cover
			K1 B 16.31	panel mount, front bezel size No. 3, flexible sealing cover K1

### Count mechanism:

Voltage	Mo-del	Max. pulse freq.	Min. pulse on time	Min. pulse interval	Pulse ratio	On time	Power consumption	Max. perm ripple voltage	Ambient temperature °C*	Order code:
V DC	0	10/sec	60 ms	40 ms	3:2	100 %	approx.1W	48 %	-10 [14 °F]	– Article number – For special voltages, please give type, voltage, kind of voltage and series e.g. B 16.31, 4.5 V DC, 0.
	1	25/sec	24 ms	16 ms	3:2	100 %	approx.2W	48 %	+60 [140 °F]	
V AC	a	18/sec	22.2 ms	33.3 ms	2:3	100%	approx.29VA		-10 ... + 55 [14 ... 131°F]	



## Type B 16.00

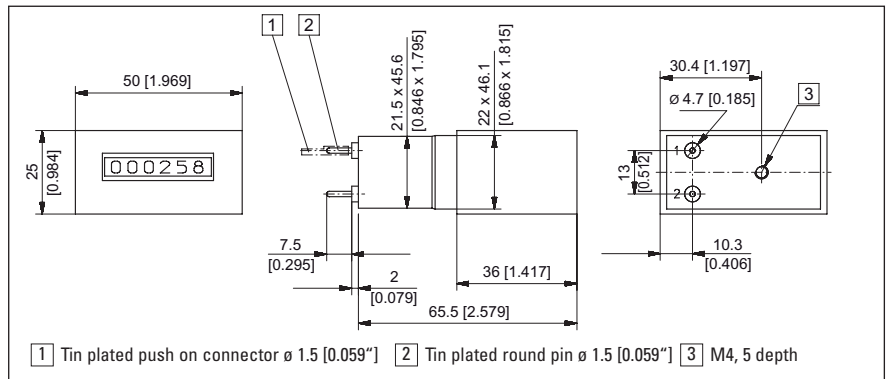

B 16.00 (6-digit)	12 V Art. no.	24 V Art. no.	115 V Art. no.	230 V Art. no.
DC (10 Imp/s)	1.230.002.012	1.230.002.013*		
DC (25 Imp/s)	1.230.002.032	1.230.002.033		
AC (18 Imp/s)		1.230.002.061	1.230.002.064	1.230.002.066

Standard colour: beige

Colour of housing black:  
Art. no. 1.230.001.XXX

## Type B 18.00

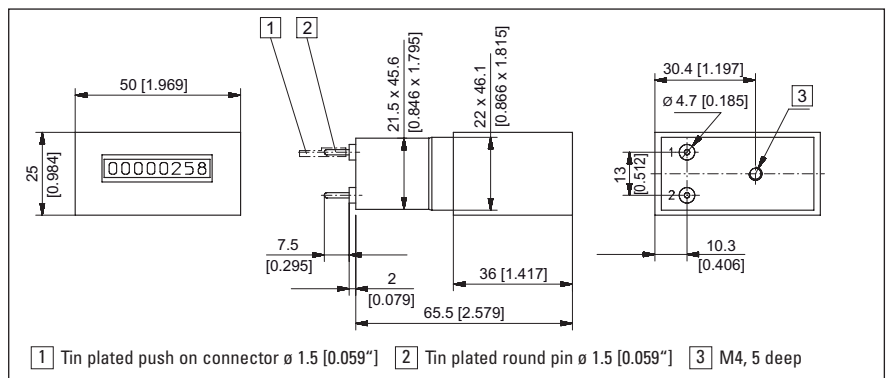

B 18.00 (8-digit)	12 V Art. no.	24 V Art. no.	115 V Art. no.	230 V Art. no.
DC (10 Imp/s)	1.260.002.012	1.260.002.013		
DC (25 Imp/s)	1.260.002.032	1.260.002.033		
AC (18 Imp/s)		1.260.002.061	1.260.002.064	1.260.002.066

Standard colour: beige

Colour of housing black:  
Art. no. 1.260.001.XXX

## Type B 16.10

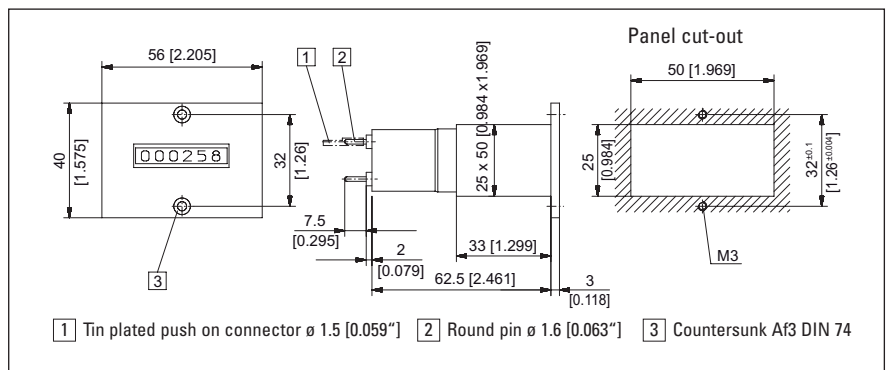

B 16.10 (6-digit)	12 V Art. no.	24 V Art. no.	115 V Art. no.	230 V Art. no.
DC (10 Imp/s)	1.230.100.012	1.230.100.013		
DC (25 Imp/s)	1.230.100.032	1.230.100.033		
AC (18 Imp/s)		1.230.100.061	1.230.100.064	1.230.100.066

Standard colour: grey

## Type B 18.10

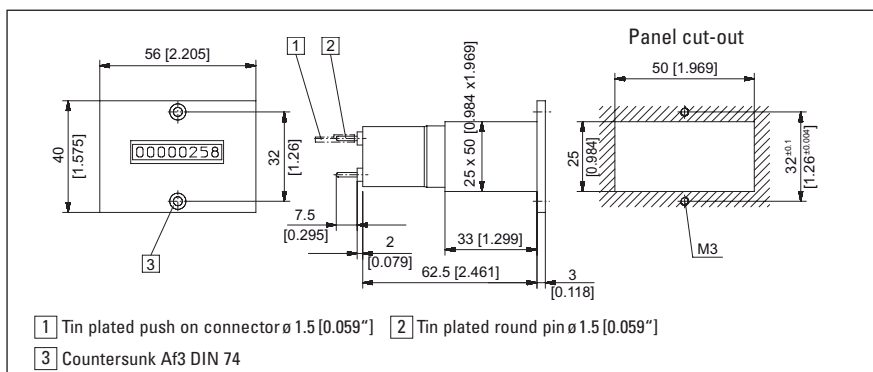

B 18.10 (8-digit)	12 V Art. no.	24 V Art. no.	115 V Art. no.	230 V Art. no.
DC (10 Imp/s)	1.260.100.012	1.260.100.013*		
DC (25 Imp/s)	1.260.100.032	1.260.100.033*		
AC (18 Imp/s)		1.260.100.061	1.260.100.064	1.260.100.066

Standard colour: grey

Colour of housing black:  
Art. no. 1.260.101.XXX

## Type B 16.20

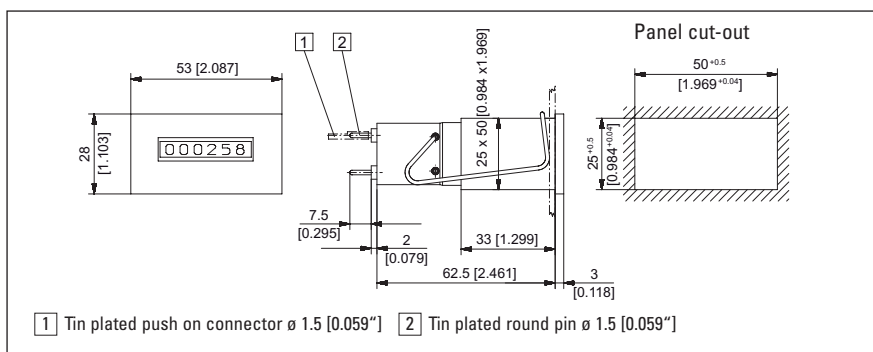

B 16.20 (6-digit)	12 V Art. no.	24 V Art. no.	115 V Art. no.	230 V Art. no.
DC (10 Imp/s)	1.230.200.012	1.230.200.013*		
DC (25 Imp/s)	1.230.200.032	1.230.200.033*		
AC (18 Imp/s)		1.230.200.061	1.230.200.064	1.230.200.066

Standard colour: grey

Colour of housing black:  
Art. no. 1.230.201.XXX

## Type B 18.20

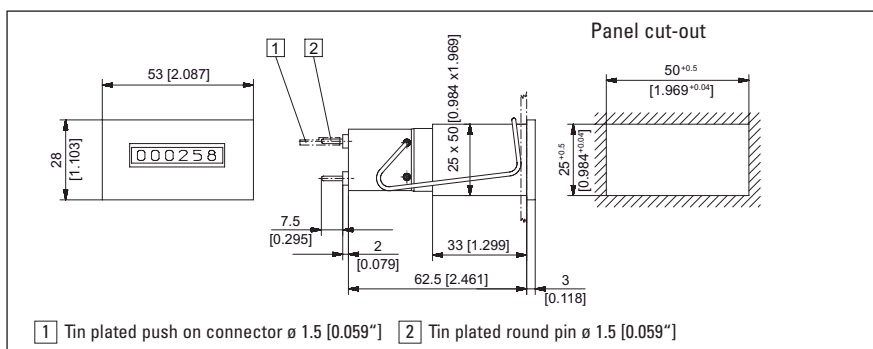

B 18.20 (8-digit)	12 V Art. no.	24 V Art. no.	115 V Art. no.	230 V Art. no.
DC (10 Imp/s)	1.260.200.012	1.260.200.013		
DC (25 Imp/s)	1.260.200.032	1.260.200.033		
AC (18 Imp/s)		1.260.200.061	1.260.200.064	1.260.200.066

Standard colour: grey

Colour of housing black:  
Art. no. 1.260.201.XXX

## Type B 16.30

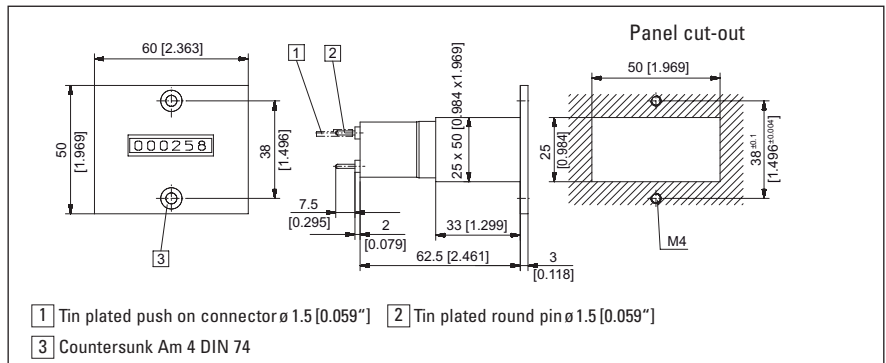

B 16.30 (6-digit)	12 V Art. no.	24 V Art. no.	115 V Art. no.	230 V Art. no.
DC (10 Imp/s)	1.230.300.012	1.230.300.013		
DC (25 Imp/s)	1.230.300.032	1.230.300.033		
AC (18 Imp/s)		1.230.300.061	1.230.300.064	1.230.300.066

Standard colour: grey

Colour of housing black:  
Art. no. 1.230.301.XXX

## Type B 18.30

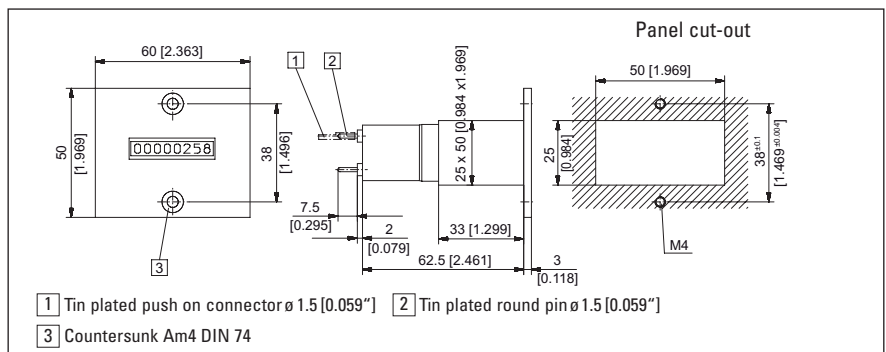

B 18.30 (8-digit)	12 V Art. no.	24 V Art. no.	115 V Art. no.	230 V Art. no.
DC (10 Imp/s)	1.260.300.012	1.260.300.013		
DC (25 Imp/s)	1.260.300.032	1.260.300.033		
AC (18 Imp/s)		1.260.300.061	1.260.300.064	1.260.300.066

Standard colour: grey

Colour of housing black:  
Art. no. 1.260.301.XXX

## Type F1 B 16.00

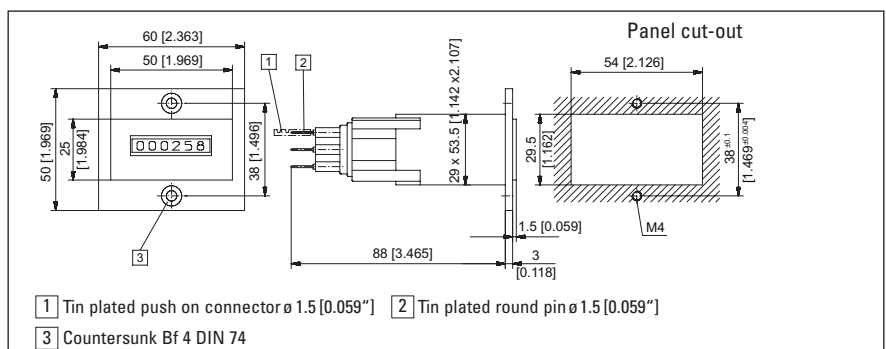

F1 B 16.00 (6-digit)	12 V Art. no.	24 V Art. no.	115 V Art. no.	230 V Art. no.
DC (10 Imp/s)	1.231.502.012	1.231.502.013		
DC (25 Imp/s)	1.231.502.032	1.231.502.033		
AC (18 Imp/s)		1.231.502.061	1.231.502.064	1.231.502.066

Standard colour: beige

Colour of housing black:  
Art. no. 1.231.501.XXX

# Display counter electromechanical



## Type F1 B 18.00

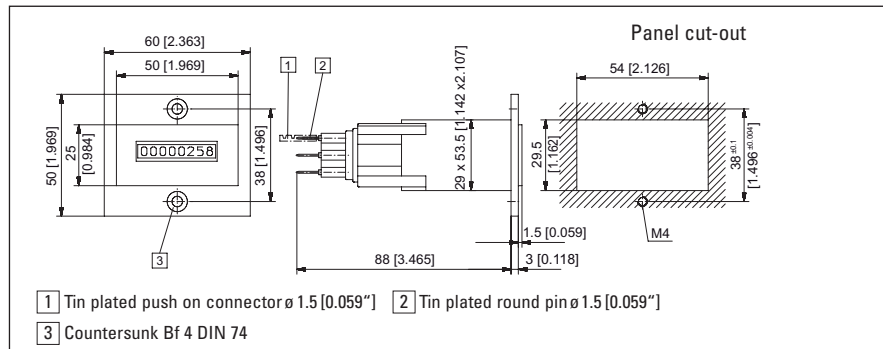

F1 B 18.00 (8-digit)	12 V Art. no.	24 V Art. no.	115 V Art. no.	230 V Art. no.
DC (10 Imp/s)	1.261.502.012	1.261.502.013		
DC (25 Imp/s)	1.261.502.032	1.261.502.033		
AC (18 Imp/s)		1.261.502.061	1.261.502.064	1.261.502.066

Standard colour: beige

Colour of housing black:  
Art. no. 1.261.501.XXX

## Type B 16.01

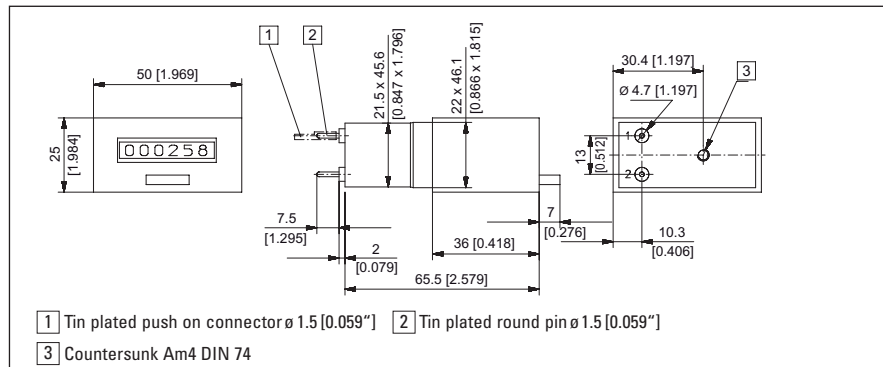

B 16.01 (6-digit)	12 V Art. no.	24 V Art. no.	115 V Art. no.	230 V Art. no.
DC (10 Imp/s)	1.230.012.012	1.230.012.013*		
DC (25 Imp/s)	1.230.012.032	1.230.012.033*		
AC (18 Imp/s)		1.230.012.061	1.230.012.064	1.230.012.066*

Standard colour: beige

Colour of housing black:  
Art. no. 1.230.011.XXX

Additional stock models:

1.230.011.013	24 V DC/0 bw
1.230.011.033	24 V DC/1 bw
1.230.011.061	24 V AC/a bw
1.230.011.066	230 V AC/a bw

\*standard stock model

## Type B 15.11

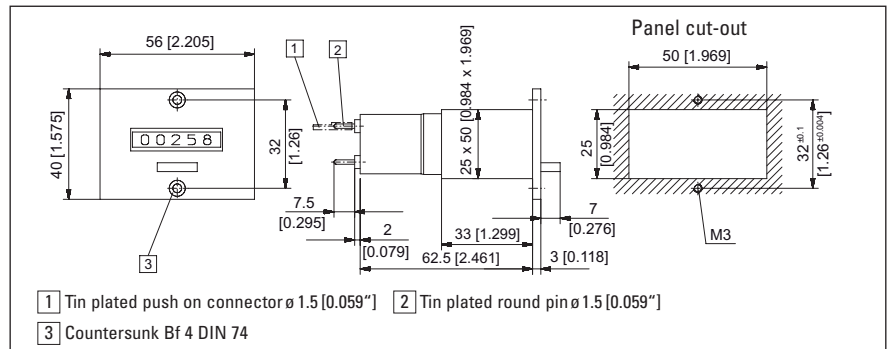

B 15.11 (5-digit)	12 V Art. no.	24 V Art. no.	115 V Art. no.	230 V Art. no.
DC (10 Imp/s)	1.200.110.012	1.200.110.013		
DC (25 Imp/s)	1.200.110.032	1.200.110.033		
AC (18 Imp/s)		1.200.110.061	1.200.110.064	1.200.110.066

Standard colour: grey

## Type B 16.11

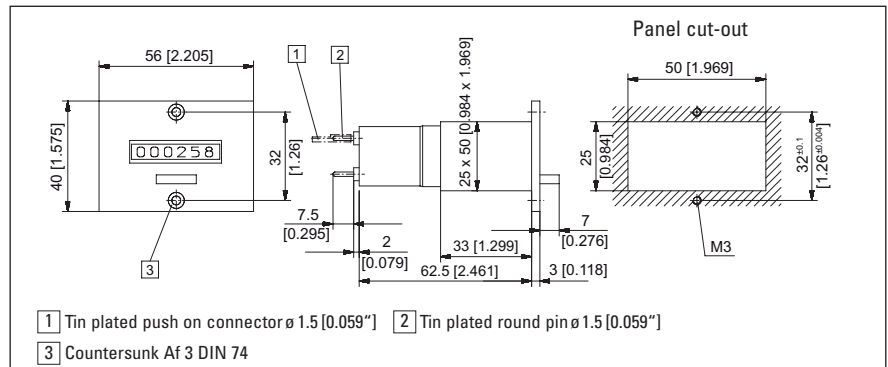

B 16.11 (6-digit)	12 V Art. no.	24 V Art. no.	115 V Art. no.	230 V Art. no.
DC (10 Imp/s)	1.230.110.012	1.230.110.013*		
DC (25 Imp/s)	1.230.110.032	1.230.110.033*		
AC (18 Imp/s)		1.230.110.061	1.230.110.064*	1.230.110.066*

Standard colour: grey

Colour of housing black:

Additional stock models:

1.230.111.033	24 V DC/0 bw
1.230.111.061	24 V DC/1 bw
1.230.111.064	24 V AC/a bw
1.230.116.066	230 V AC/a bw fs

\*standard stock model

## Type B 15.21

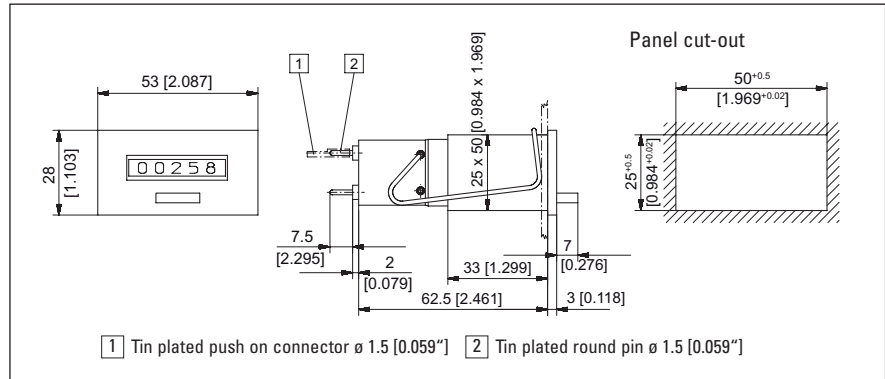

B 15.21 (5-digit)	12 V Art. no.	24 V Art. no.	115 V Art. no.	230 V Art. no.
DC (10 Imp/s)	1.200.210.012	1.200.210.013		
DC (25 Imp/s)	1.200.210.032	1.200.210.033		
AC (18 Imp/s)		1.200.210.061	1.200.210.064	1.200.210.066

Standard colour: grey

## Type B 16.21

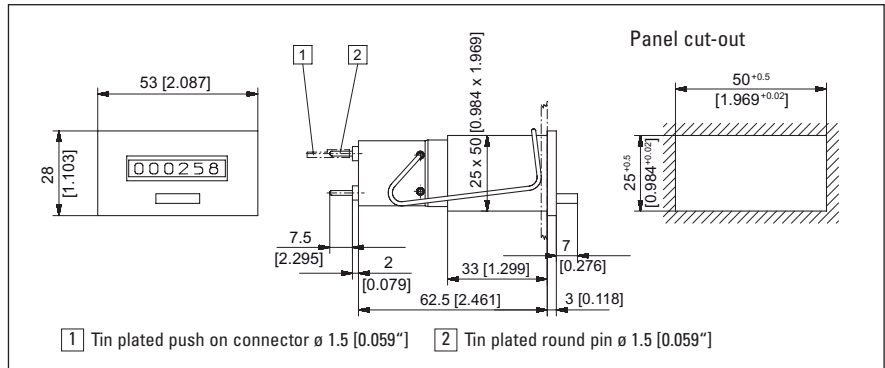

B 16.21 (6-digit)	12 V Art. no.	24 V Art. no.	115 V Art. no.	230 V Art. no.
DC (10 Imp/s)	1.230.210.012	1.230.210.013*		
DC (25 Imp/s)	1.230.210.032	1.230.210.033*		
AC (18 Imp/s)		1.230.210.061	1.230.210.064	1.230.210.066*

Standard colour: grey

Colour of housing black:  
Art. no. 1.230.211.XXX

\*standard stock model

## Type B 16.31

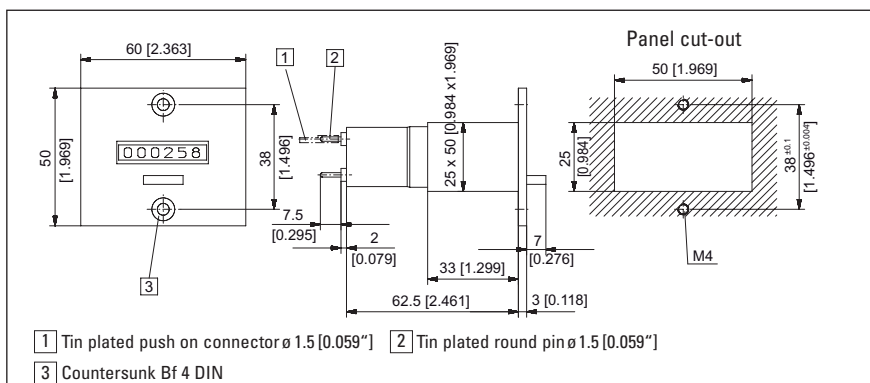

B 16.31 (6-digit)	12 V Art. no.	24 V Art. no.	115 V Art. no.	230 V Art. no.
DC (10 Imp/s)	1.230.310.012	1.230.310.013*		
DC (25 Imp/s)	1.230.310.032	1.230.310.033		
AC (18 Imp/s)		1.230.310.061	1.230.310.064	1.230.310.066

Standard colour: grey

Colour of housing black:  
Art. no. 1.230.311.XXX

\*standard stock model

## Type F1 B 16.01

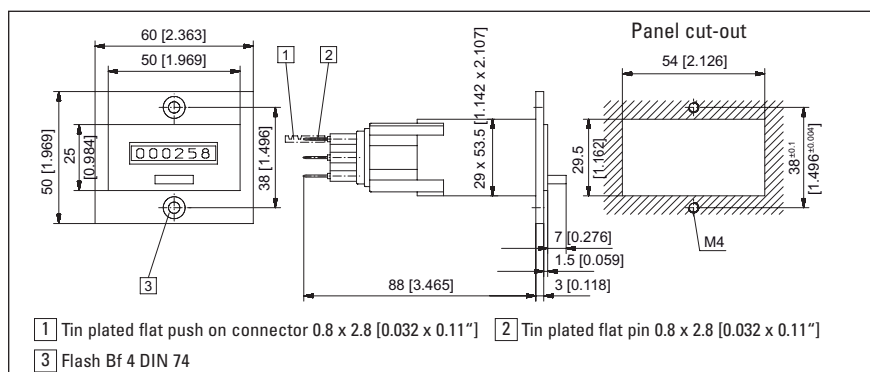

F1 B 16.01 (6-digit)	12 V Art. no.	24 V Art. no.	115 V Art. no.	230 V Art. no.
DC (10 Imp/s)	1.231.512.012	1.231.512.013		
DC (25 Imp/s)	1.231.512.032	1.231.512.033		
AC (18 Imp/s)		1.231.512.061	1.231.512.064	1.231.512.066

Standard colour: beige

Colour of housing black:  
Art. no. 1.231.511.XXX



B 15.21 vs



Dvs B 16.31



Dv B 16.31



K1B 15.31



945.2

## Totaliser MK 14 - MK 18 without zero reset



- 6- or 8-digit totaliser without zero reset
- 4- or 6-digit Totaliser with manual, electrical or manual and electrical reset
- Integrated electrical 0-reset fitted at MK 16
- MK 14: electrical 0-reset to the rear side of counter

### Applications:

registering of pieces, units, events, periods of time

### Technical data:

Count mechanism:	
Electrical connection:	flat pin 0.8 x 2.8 mm [0.032 x 0.11"] with tab receptacles
Rated voltage:	12/24/48/60/115/230 V DC $\pm 10\%$ 24/48/60/115/230 V AC $\pm 10\%$
Height of figures:	4 mm [0.158"]
Housing:	Makrolon, colour grey, similar to RAL 7001
Colour of figures:	white on black
Shaft:	stainless steel
Mounting position:	any
Operating life:	approx. 200 x 10 <sup>6</sup> pulses
Weights:	Zero reset manual electrical MK 14 85 g [2.998 oz] 145 g [5.115 oz] MK 16 100 g [3.527 oz] 140 g [4.938 oz]
Test voltage:	2000 V - effective
Acceleration influence:	3 g up to 10 Hz 6 g up to 15 Hz independent of 10 g 20 – 300 Hz position

Reset magnet:	
Power consumption:	approx. 9 W at DC approx. 12 VA at AC
Rated voltage:	12/24/48/60/115/230 V DC $\pm 10\%$ 24/48/60/115/230 V AC $\pm 10\%$
Permissible residual ripple:	max. 48 %
Min. pulse time:	0.25 sec, during 0.3 sec no count pulse is allowed.
Cycle duration factor:	15 %, max. 1.0 min at MK 16 10 %, max. 40 sec at MK 14
Options:	– Extended temperature range

### Type Series:

zero reset without		zero reset manual		zero reset man. + electr.		Description
6-digit	8-digit	4-digit	6-digit	4-digit	6-digit	
–	MK 18.10	MK 14.11	MK 16.11	–	–	panel mount 2 screw holes
MK 16.20	MK 18.20	MK 14.21	MK 16.21	–	MK 16.23	panel mount with spring clip

### Order code

– Article number  
– For special voltages, please give type, voltage, kind of voltage and series e.g. MK 16.21, 48 V AC, type a.

### Count mechanism:

voltage	Model	Max. pulse freq.	Min. pulse on time	Min. pulse interval	Pulse ratio	On time	Power consumption	Max. perm ripple voltage	Ambient. temperature °C*
V DC	0	10/sec	64 ms	40 ms	3:2	100 %	approx. 1W	48 %	–10 [14 °F]
	1	25/sec	24 ms	16 ms	3:2	100 %	approx. 2W	48 %	+45 [113 °F]
V AC	a	18/sec	22.2 ms	33.3 ms	2:3	100%	approx. 29 VA	-	–10 ... + 45 [14 ... 113 °F]

### Connection diagram: (type: 0 u.1, DC)

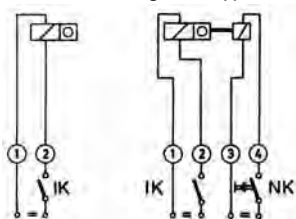

IK = Pulse contact NK = 0 contact

### (type: a, AC)

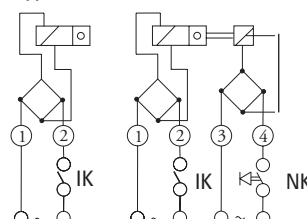

IK = Pulse contact NK = 0 contact

\*non-condensing



## Type MK 16.20

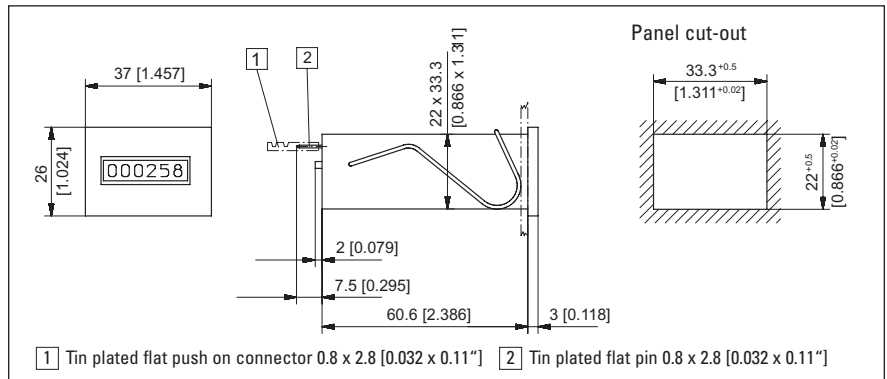

MK 16.20 (6-digit)	12 V Art. no.	24 V Art. no.	115 V Art. no.	230 V Art. no.
DC (10 Imp/s)	1.330.200.012	1.330.200.013		
DC (25 Imp/s)	1.330.200.032	1.330.200.033		
AC (18 Imp/s)		1.330.200.061	1.330.200.064	1.330.200.066

Colour of housing black:  
Art. no. 1.330.201.XXX

## Type MK 18.10

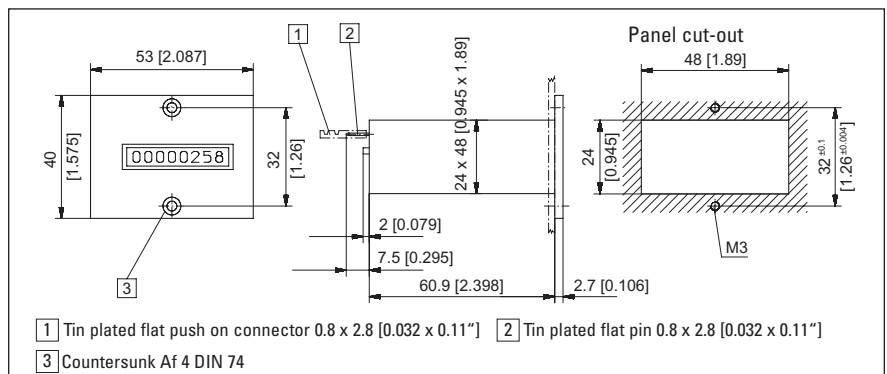

MK 18.10 (8-digit)	12 V Art. no.	24 V Art. no.	115 V Art. no.	230 V Art. no.
DC (10 Imp/s)	1.360.100.012	1.360.100.013		
DC (25 Imp/s)	1.360.100.032	1.360.100.033		
AC (18 Imp/s)		1.360.100.061	1.360.100.064	1.360.100.066

Colour of housing black:  
Art. no. 1.360.101.XXX

## Type MK 18.20

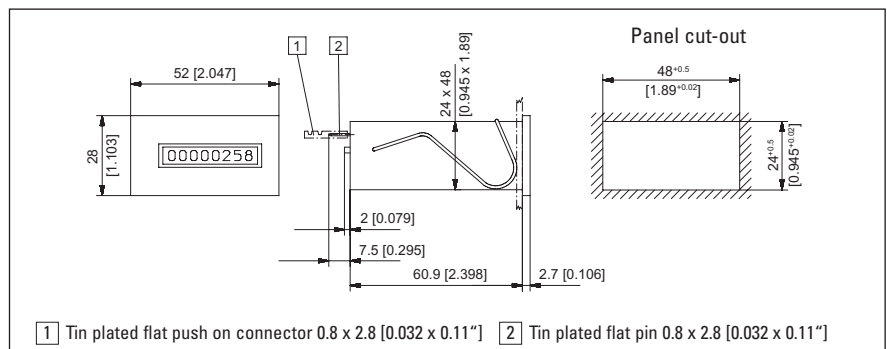

MK 18.20 (8-digit)	12 V Art. no.	24 V Art. no.	115 V Art. no.	230 V Art. no.
DC (10 Imp/s)	1.360.200.012	1.360.200.013		
DC (25 Imp/s)	1.360.200.032	1.360.200.033		
AC (18 Imp/s)		1.360.200.061	1.360.200.064	1.360.200.066

Colour of housing black:  
Art. no. 1.360.201.XXX

## Type MK 14.11

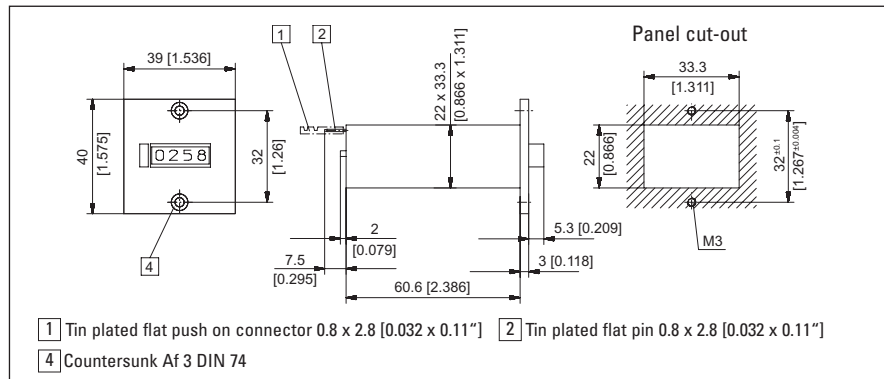

manual 0 reset

MK 14.11 (4-digit)	12 V Art. no.	24 V Art. no.	115 V Art. no.	230 V Art. no.
DC (10 Imp/s)	1.310.110.012	1.310.110.013		
DC (25 Imp/s)	1.310.110.032	1.310.110.033		
AC (18 Imp/s)		1.310.110.061	1.310.110.064	1.310.110.066

Colour of housing black:  
Art. no. 1.310.111.XXX

## Type MK 14.21

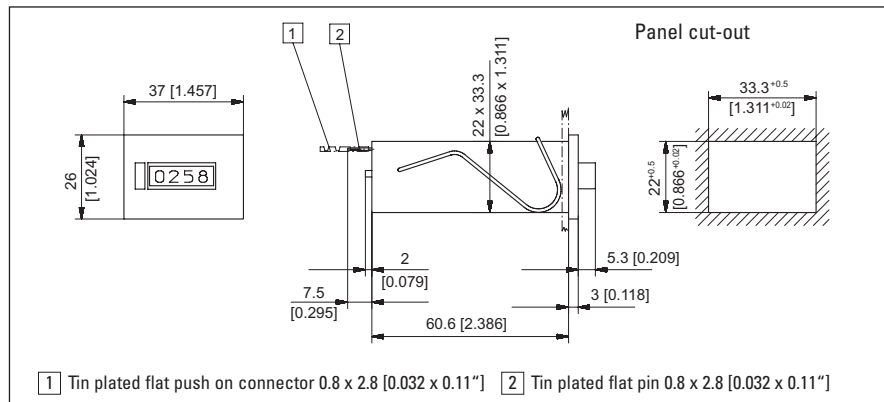

manual 0 reset

MK 14.21 (4-digit)	12 V Art. no.	24 V Art. no.	115 V Art. no.	230 V Art. no.
DC (10 Imp/s)	1.310.210.012	1.310.210.013		
DC (25 Imp/s)	1.310.210.032	1.310.210.033		
AC (18 Imp/s)		1.310.210.061	1.310.210.064	1.310.210.066

Colour of housing black:  
Art. no. 1.310.211.XXX

## Type MK 16.11

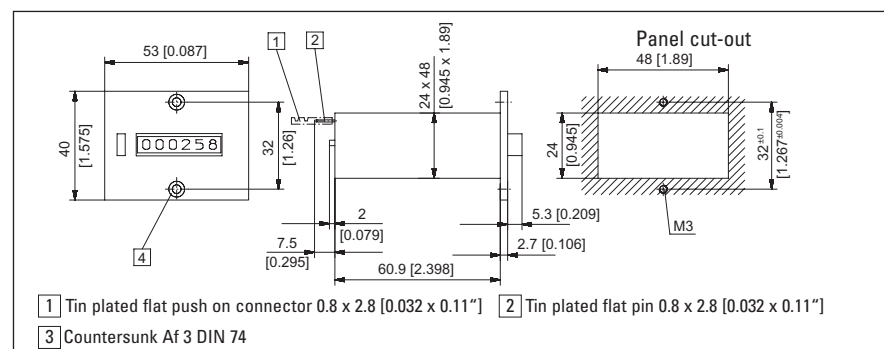

manual 0 reset

MK 16.11 (6-digit)	12 V Art. no.	24 V Art. no.	115 V Art. no.	230 V Art. no.
DC (10 Imp/s)	1.340.110.012	1.340.110.013		
DC (25 Imp/s)	1.340.110.032	1.340.110.033		
AC (18 Imp/s)		1.340.110.061	1.340.110.064	1.340.110.066

Colour of housing black:  
Art. no. 1.340.111.XXX

## Type MK 16.21

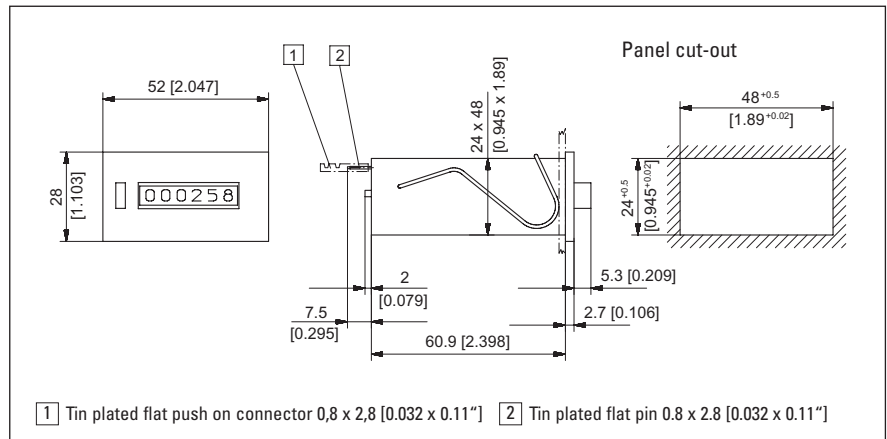

manual 0 reset

MK 16.21 (6-digit)	12 V Art. no.	24 V Art. no.	115 V Art. no.	230 V Art. no.
DC (10 Imp/s)	1.340.210.012	1.340.210.013		
DC (25 Imp/s)	1.340.210.032	1.340.210.033		
AC (18 Imp/s)		1.340.210.061	1.340.210.064	1.340.210.066

Colour of housing black:  
Art. no. 1.340.211.XXX

## Type MK 16.23

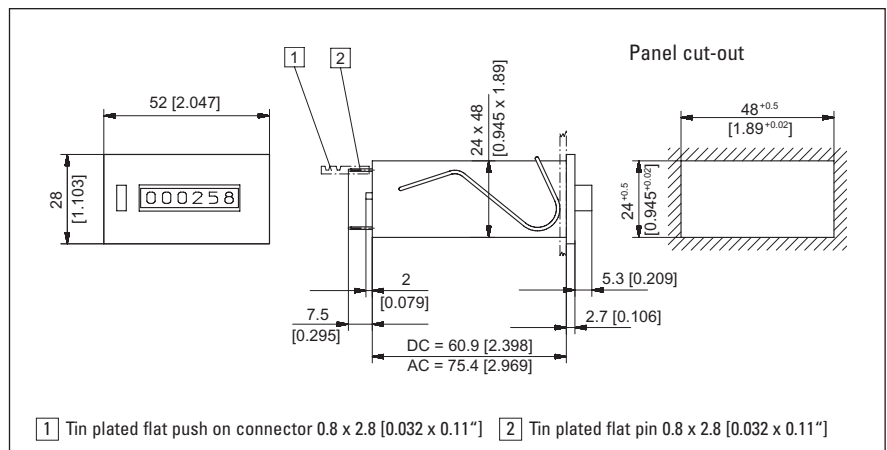

manual and electrical 0 reset

MK 16.23 (6-digit)	12 V Art. no.	24 V Art. no.	115 V Art. no.	230 V Art. no.
DC (10 Imp/s)	1.340.230.012	1.340.230.013		
DC (25 Imp/s)	1.340.230.032	1.340.230.033		
AC (18 Imp/s)		1.340.230.061	1.340.230.064	1.340.230.066

Colour of housing black:  
Art. no. 1.340.231.XXX

## Totaliser E 16 with manual and electrical zero reset



- 6-digit adding pulse counter with manual or manual and electrical zero reset
- The counters have plastic front plates and metal housing

**Application:**  
general event counting

### Technical data:

<b>Count mechanism:</b>	
Electrical connection:	screw terminal
Rated voltage:	12/ <del>24</del> /48/60/115/230 V DC $\pm 10\%$ 24/48/60/115/ <del>230</del> V AC $\pm 10\%$
Height of figures:	4 mm [0.158"]
Colour of front plate:	grey
Colour of figure:	white on black
Mounting position:	any
Operating life:	approx. $250 \times 10^6$ pulses
Weight:	E 16.11      170 g [5.997 oz] E 16.13      230 g [8.113 oz]
Test voltage:	2000 V ~ effective
Acceleration influence:	3 g at 10 Hz 6 g at 15 Hz    independent of position 10 g at 20 ... 300 Hz

<b>Zeroing magnet:</b>	
Power consumption:	approx. 9.5 W at DC approx. 13 VA at AC
Rated voltage:	4/6/12/24/48/60/115/230 V DC $\pm 10\%$ 24/48/60/115/230 V AC $\pm 10\%$
Min pulse on time:	0.15 sec, during 0.2 sec no pulse count is allowed
<b>Options:</b>	
	– count speed 50 Imp/s at DC – key locking reset

### Series:

Zero reset manual	Zero reset manual and electrical	Description
E 16.11	E 16.13	panel mount with 2 fixing holes

**Order code:**  
– Article number  
– For special voltages, please give type, voltage, kind of voltage and series e.g. E 16.11, 48 V AC, type a.

### Count mechanism:

Voltage	Model	Max. pulse freq.	Min. pulse on time	Min. pulse interval	Pulse ratio	On time	Power consumption	Max. perm ripple voltage	Ambient temperature °C
V DC	I	25/sec	24 ms	16 ms	3:2	100 %	approx. 2 W	48 %	-10 ... [14 °F]
V AC	a	18/sec	22.2 ms	33.3 ms	2:3	100%	approx. 3.2 VA		+45 [113 °F]

### Connection diagram: (type: 0 u.1, DC)

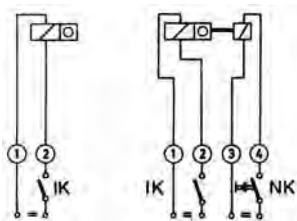

IK = Pulse contact NK = zero contact

### (type: a, AC)

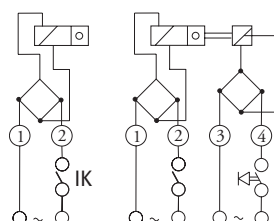

IK = Pulse contact NK = zero contact

## Type E 16.11 and E 16.13

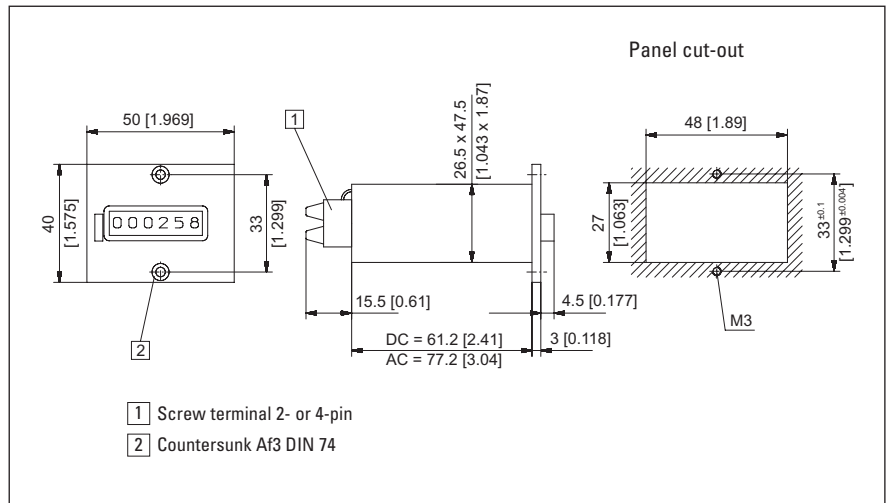

### manual 0 reset

E 16.11 (6-digit)	12 V Art. no.	24 V Art. no.	115 V Art. no.	230 V Art. no.
DC (25 Imp/s)	1.520.110.032	1.520.110.033		
AC (18 Imp/s)		1.520.110.061	1.520.110.064	1.520.110.066

### manual and electrical 0 reset

E 16.13 (6-digit)	12 V Art. no.	24 V Art. no.	115 V Art. no.	230 V Art. no.
DC (25 Imp/s)	1.520.130.032	1.520.130.033		
AC (18 Imp/s)		1.520.130.061	1.520.130.064	1.520.130.066

## Pneumatic Pulse counter PMK 14 - PMK 18



- Low cost pneumatic Totaliser
- PMK 14 and PMK 16 with manual zero reset
- PMK 18 without zero reset
- Counting is effected through a piston driven armature system
- No leakage

### Applications:

pneumatically operated instruments and equipments, use in Ex hazardous areas

### Technical data:

Pneumatic connections with M 5 inner thread, 4 mm [0.158"] depth	
Air purity:	oil free or oil containing, the filter required must eliminate impurities $\geq 40 \mu\text{m}$ .
Mounting position:	any
L signal:	1.5 ... 8 bar $\pm 15 \%$
O signal:	$\leq 0.15$ bar
Max. safe pressure:	9 bar (statical)
Max. pulse frequency:	17 Hz at 1.5 bar 5 Hz at 8 bar depends on tube length
Pulse ratio:	1:1 at max. Pulse frequency
Hose length:	at 50 Hz 0.3 m [0.328 Yard] (transmitter - counter) at 25 Hz 0.4 m [0.438 Yard] at 10 Hz 0.5 m [0.547 Yard]
Height of figures:	4 mm [0.158"]
Colour of figures:	white on black

<b>Counting:</b>	
Connection volume:	0.19 m <sup>3</sup> [11.595 cubic inches]
Options:	<ul style="list-style-type: none"> <li>– Colour of housing: black (Art. no. see type)</li> <li>– Connector for polyamide hose <math>\varnothing 4 \times \varnothing 6</math> mm [<math>\varnothing 0.158 \times \varnothing 0.236</math>"]</li> <li>– Quick connection for tube outside diameter <math>\varnothing 4</math> mm [0.158"]: QSM-M5-4 M140 620</li> </ul>

### Series:

4-digit with 0 reset	6-digit with 0 reset	8-digit without reset	Description
PMK 14.11	PMK 16.11	PMK 18.10	Panel mount 2 screw holes
PMK 14.21	PMK 16.21	PMK 18.20	Panel mount spring clip

### Type PMK 14.11



PMK 14.11, grey:	Art. no. 3.802.110*
PMK 14.11, black:	Art. no. 3.802.111

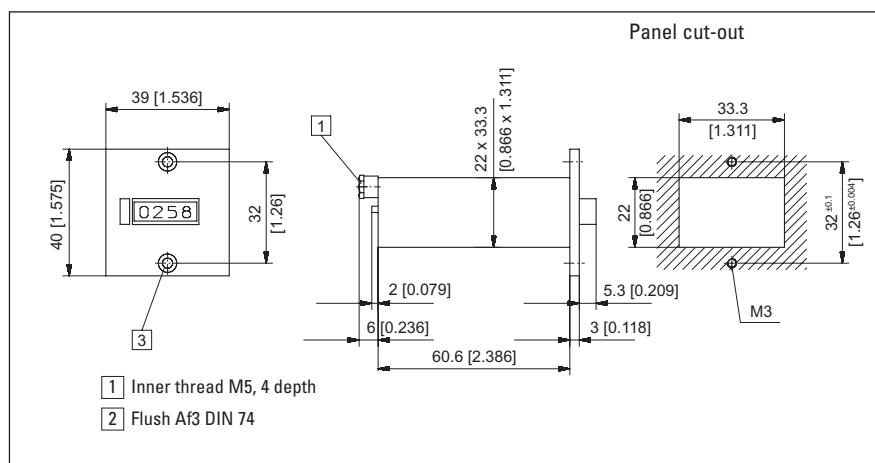

## Type PMK 14.21



PMK 14.21, grey:	Art. no. 3.802.210
PMK 14.21, black:	Art. no. 3.802.211

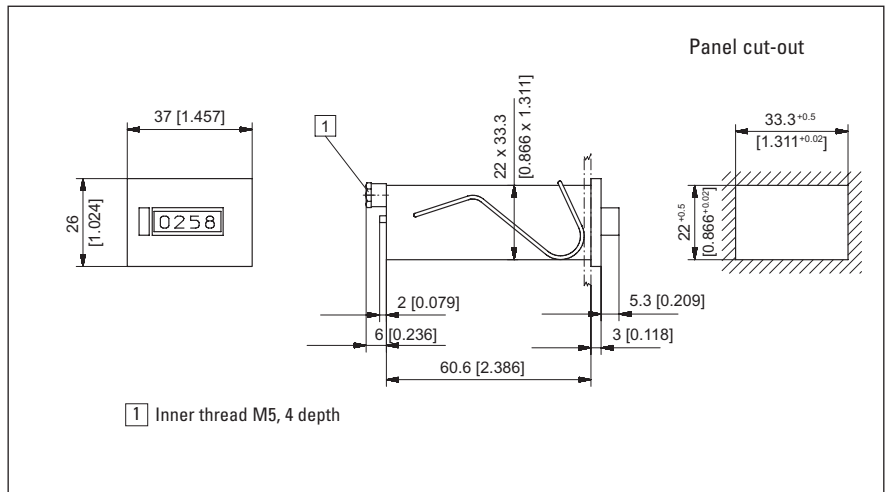

## Type PMK 16.11



PMK 16.11, grey:	Art. no. 3.804.110*
PMK 16.11, black	Art. no. 3.804.111

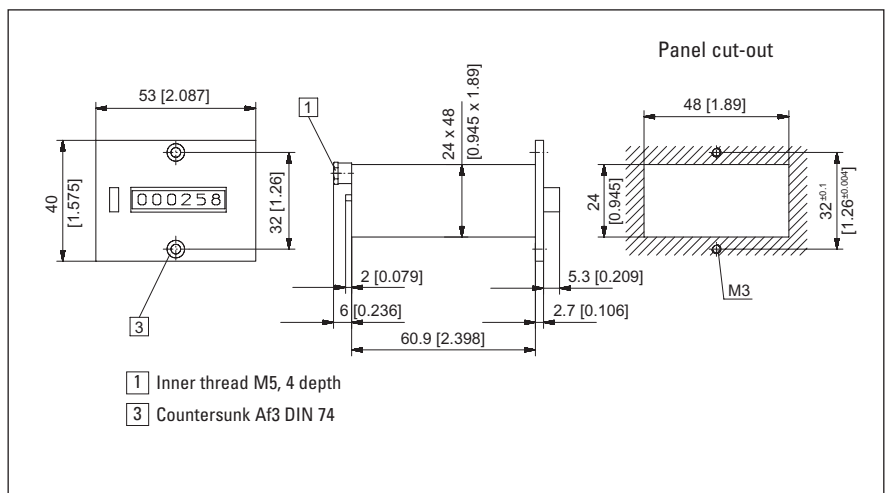

## Type PMK 16.21



PMK 16.21, grey:	Art. no. 3.804.210
PMK 16.21, black	Art. no. 3.804.211

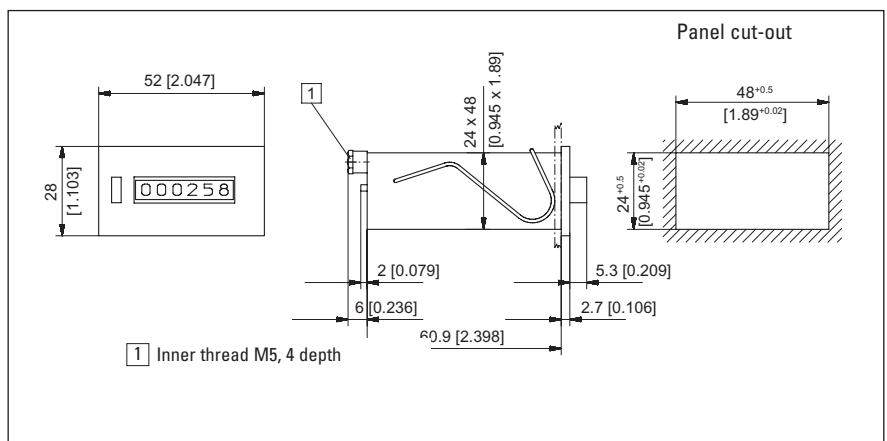

# Display counter pneumatic



## Type PMK 18.10



PMK 18.10, grey:	Art. no. 3.805.100
PMK 18.10, black:	Art. no. 3.805.101

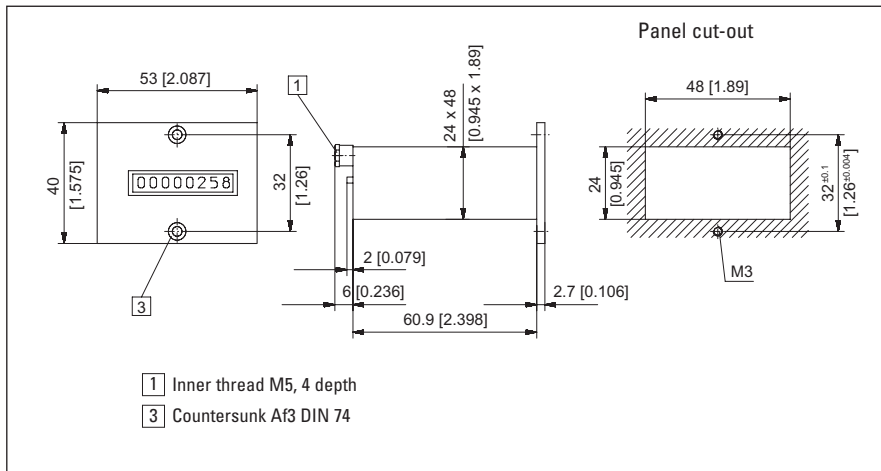

## Type PMK 18.20



PMK 18.20, grey:	Art. no. 3.805.200
PMK 18.20, black:	Art. no. 3.805.201

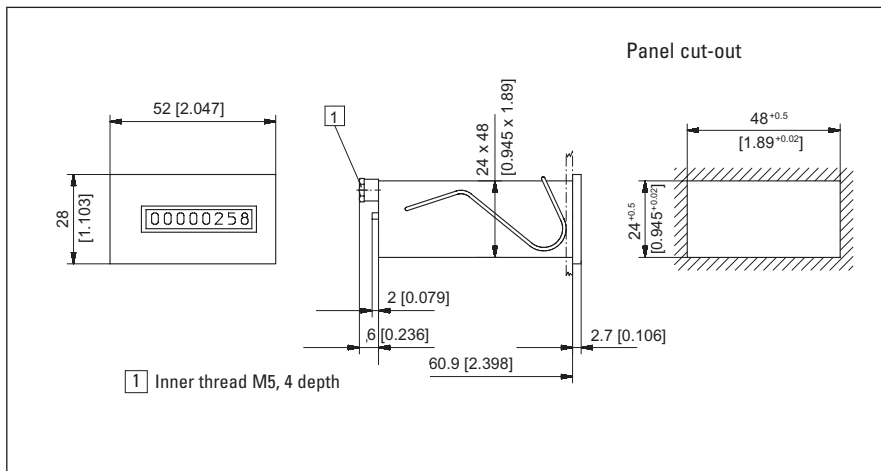



## KWH 17



**NEW**  
5 years warranty



### Product features

- 7-digit drum-type counting mechanism (cyclometer) with pulse control, for installation in kWh meters
- Stepper motor drive
- Each incoming pulse advances the decimal place of the counting mechanism by 1/100 of a revolution

### Your benefit

- **5 year warranty\***  
very reliable: your end product is easier to sell
- Only 25 mW power consumption permits trouble-free PCB mounting
- Data retention on power-failure
- Large digits as with conventional Ferraris meters

### Applications:

module for installation in electro-mechanical kWh meters

\* for fixed installations and use in accordance with the technical data

### Technical data:

Driving mechanism:	stepper motor	Stepper motor
Nominal voltage:	5 V DC $\pm 10\%$	10 V DC $\pm 10\%$
Activation:	rectangular- or needle-shaped pulses	Rectangular- or needle-shaped pulses
Electrical connection:	solder pins	Solder pins
Display:	7-digit display, decimal place with additional 1/100 division Counter reading on delivery: 000 0001 $\pm 3$ digits	
Figures:	white on black	
Coil resistance:	1 k $\Omega$	3.6 k $\Omega$
Power consumption:	25 mW	28 mW
Height of figures:	5 x 3 mm [0.197 x 0.118"]	5 x 3 mm [0.197 x 0.118"]
Ambient temperature:	-20 ... +70 °C [-4 ... 158 °F]	-20 ... +70 °C [-4 ... 158 °F]

### Options:

Different mounting possibilities:	on request
Magnetic shield:	with or without
Alternative operating voltage:	on request
Alternative coil resistance:	on request
Extended temperature range:	-40 ... +90 °C [-40 ... 194 °F]

### Pulse diagrams:

Rectangular shaped pulses

Pulses by capacitor charge or discharge

Recommended Capacitor

5 V DC version 100  $\mu$ F

10 V DC version 33  $\mu$ F

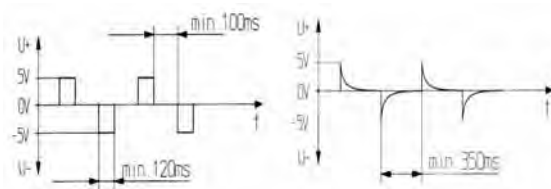

## KWH 17

### Dimensions:

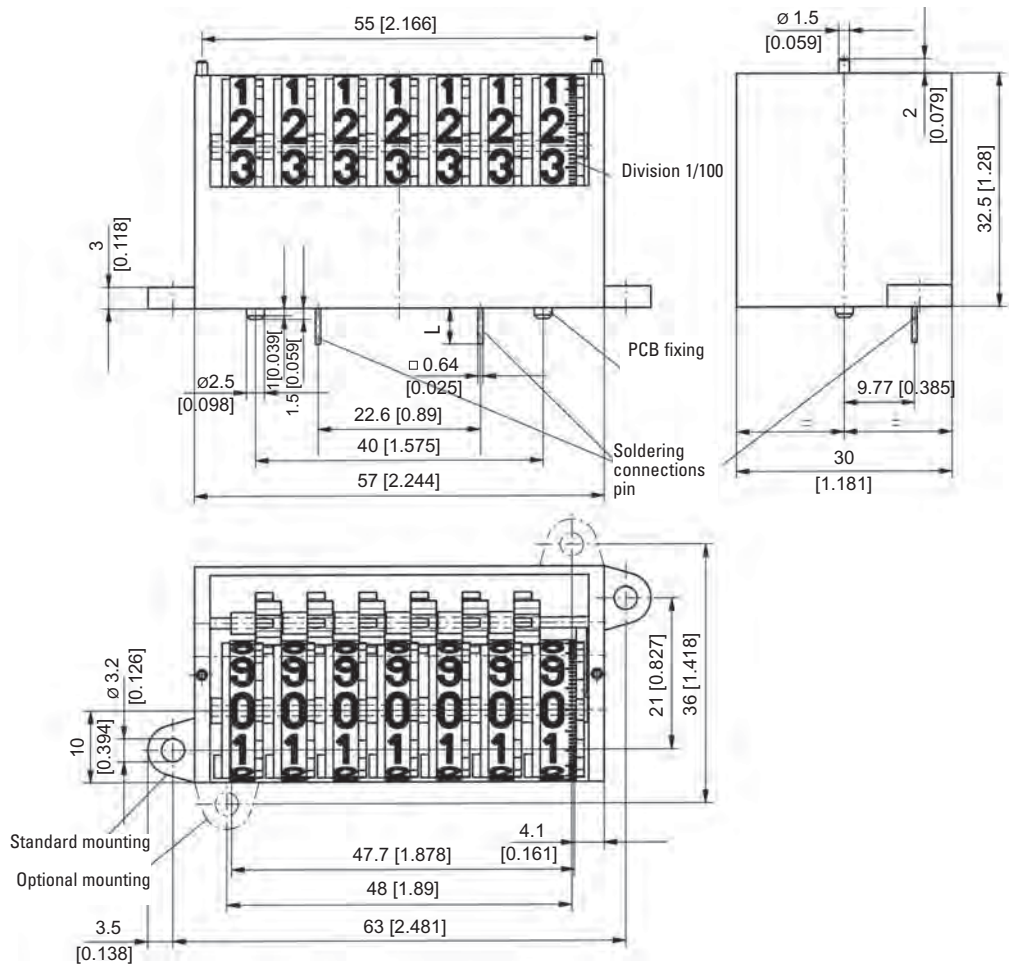

### Order Code:

**1.94X.XXX.XXX.XXX**

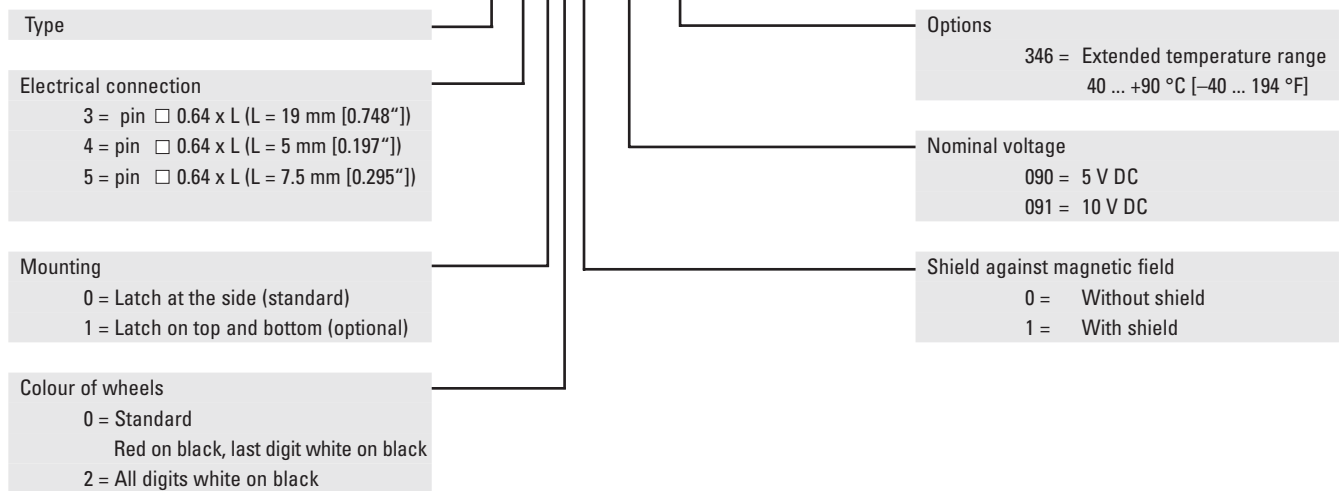

## Pulse counter – Time meter HC 77



- **Combination counter consists of hour meter and adding counter in one**
- Without reset
- High shock resistance
- Magnified figures
- Protection IP 52 front side
- Data retention if power is lost
- Long service life
- UL-approval

### Applications:

general counting,  
service interval for  
measurement systems  
(respiratory ventilators, oxygen  
machines, dialysis machines),  
small appliances, UV lamps,  
display panels in cars

### Technical data:

Electrical connection:	Flat pin 0,8 x 6,3 mm [0.032 x 0.248"] with screw terminal tightening torque max. 0,8 Nm
Power consumption:	10 ... 30 V DC: approx. 1 W 36 ... 80 V DC: approx. 1.65 W 100 ... 130 V DC: approx. 1.75 W 20 ... 30 V AC, 50 Hz: approx. 0.53 VA 42...48 V AC, 50 Hz: approx. 0.53 VA 100...130 V AC, 50 Hz: approx. 1.43 VA 187...264 V AC, 50 Hz: approx. 3.0 VA
Rated voltages:	20 ... 30/42 ... 48/100 ... 130/187 ... 264 V AC 50 or 60 Hz, 10 ... 30/36 ... 80/100 ... 130 V DC
On time:	100 %
Count mode:	adding
Height of figures:	4 x 1.7 mm [0.158 x 0.067"]
Colour of figures:	hour: white on black decimal: red on black
Operating indicator of the running time meter:	
AC:	Fast rotating wheel with red dashes: 99999.99 h
DC:	1/100 h display turns continuously by 1 digit in 36 s: 99999.99 h
Accuracy:	AC: Supply frequency + 30 ms DC: < 0.003 % (24 h)
Reset:	no
Ambient temperature:	-15 ... +50 °C [5 ... 122 °F]
Mounting position:	any
Protection:	IP 65 (from front, when built in)
Colour of housing:	black
Weights:	
HC 77	65 g [2.293 oz]
Plug in frame 55	8 g [0.282 oz]

Plug in frame 72	13 g
Options:	<ol style="list-style-type: none"> <li>1. Colour of housing: grey Art-No. 3.55X.400.XXX</li> <li>2. Flat pin 0.8 x 6.3 mm [0.032 x 0.248"] Art-No.: 3.55X.40X.XXX.011</li> <li>3. Separate connections for running time meter and adding counter. This model is available for AC or DC (not mixed) Adding counter max. 10 Imp/s Electrical connections: 2 x cable 2 x 0.5 mm<sup>2</sup> [0.00077 square yards] NYFAZ, 0.5 m [0.547 yard] long (hour meter cable red/black, adding counter grey cable) Art-No. 3.55X.40X.XXX.060</li> <li>4. Sealed window (IP 65 front) with: <ul style="list-style-type: none"> <li>- Screw terminal: Art-No. 3.55X.40X.XXX.419</li> <li>- Flat pin 0.8 x 6.3 mm [0.032 x 0.248"] Art-No. 3.55X.40X.XXX.062</li> <li>- Separated connections (cable) Art-No. 3.55X.40X.XXX.061</li> </ul> </li> </ol>
Approvals:	UL for USA and Canada E128604
Order information:	Art-No. (for special voltages etc. indicate exact model, voltage and frequency e.g. HC 77, 120 V AC, 60 Hz)

Meter with separate connections (rear view)

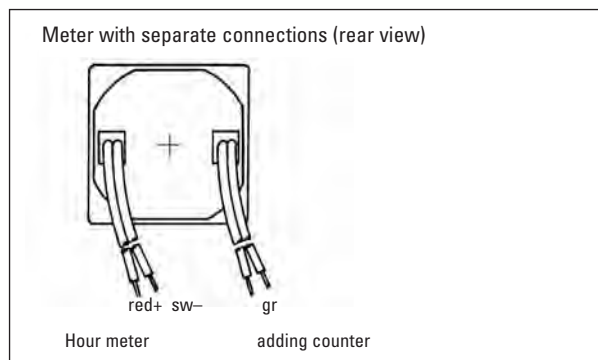

## Pulse counter – Time meter HC 77

### HC 77

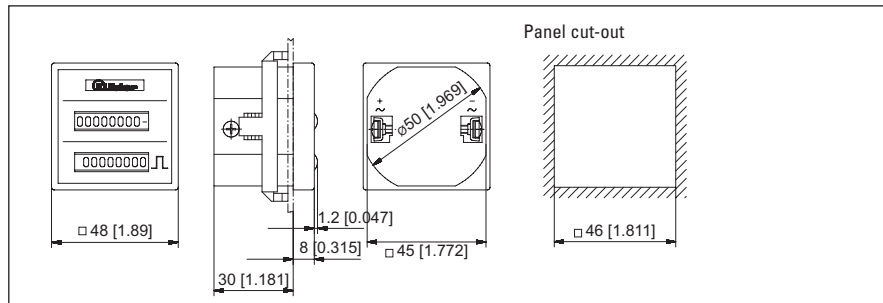

Voltage	Art-No. (AC), 50 Hz	Art-No. (AC), 60 Hz	Art-No. (V DC)
10 ... 30			3.550.401.351
20 ... 30	3.550.401.071	3.550.401.081	
36 ... 80			3.550.401.353
42 ... 48	3.550.401.072	3.550.401.082	
100 ... 130	3.550.401.074	3.550.401.084	3.550.401.381
187 ... 264	3.550.401.075	3.550.401.085	

Colour of housing grey: Art. no.3.550.400.XXX

### HC 77.55

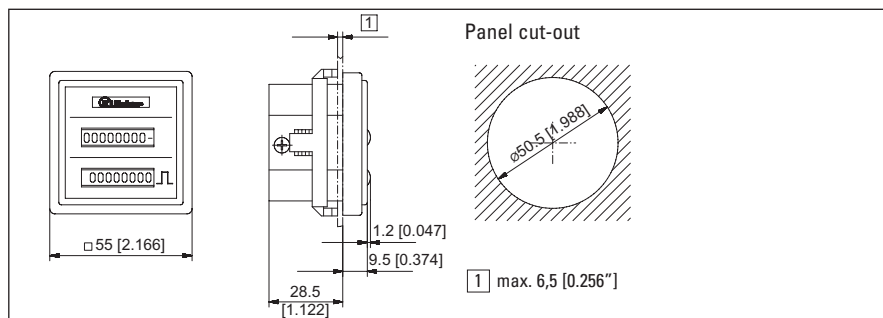

Voltage	Art-No. (AC), 50 Hz	Art-No. (AC), 60 Hz	Art-No. (V DC)
10 ... 30			3.551.401.351
20 ... 30	3.551.401.071	3.551.401.081	
36 ... 80			3.551.401.353
42 ... 48	3.551.401.072	3.551.401.082	
100 ... 130	3.551.401.074	3.551.401.084	3.551.401.381
187 ... 264	3.551.401.075	3.551.401.085	

Colour of housing grey: Art. no. 3.551.400.XXX

### HC 77.72

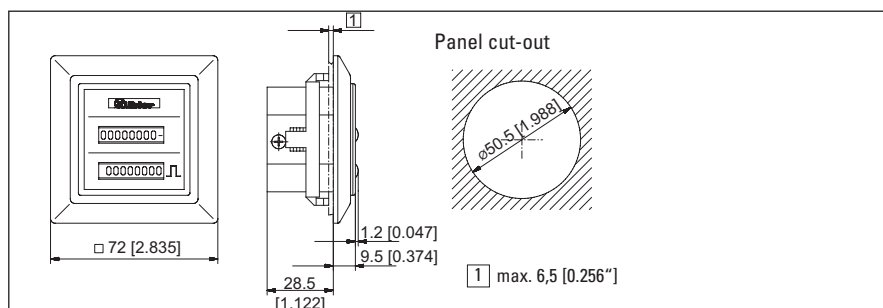

Voltage	Art-No. (AC), 50 Hz	Art-No. (AC), 60 Hz	Art-No. (V DC)
10 ... 30			3.552.201.351
20 ... 30	3.552.401.071	3.552.401.081	
36 ... 80			3.552.201.353
42 ... 48	3.552.401.072	3.552.401.082	
100 ... 130	3.552.401.074	3.552.401.084	3.552.201.381
187 ... 264	3.552.401.075	3.552.401.085	

For panel cut-outs 66 x 66 mm [2.599 x 2.599"] and 68 x 68 mm [2.678 x 2.678"] adapters are available as accessories.

Adapter 66 x 66 mm [2.599 x 2.599"]:

Art. no. T.009.423

Adapter 68 x 68 mm [2.678 x 2.678"]:

Art. no. T.009.420

Colour of housing grey: 3.552.400.XXX

## Pulse counter – Time meter SHC 77



- **Combination counter consists of time meter and adding counter in one**
- Without reset
- High shock resistance
- Magnified figures
- Protection IP 52 front side
- Data retention if power is lost
- Long service life
- UL-approval

### Applications:

general counting, service interval for measurement systems (respiratory ventilators, oxygen machines, dialysis machines), small appliances, UV lamps, display panels in cars.

### Technical data:

Electrical connection:	SHC 77:	Screw terminal tightening torque max. 0,8 Nm
	SHC 77.60:	2 x cable 2 x 0.5 mm <sup>2</sup> NYFAZ, 0.5 m [0.547 square yards] long Hour meter red/black Adding counter grey
Power consumption:	10 ... 30 V DC:	approx. 1 W
	36 ... 80 V DC:	approx. 1.65 W
	100 ... 130 V DC:	approx. 1.75 W
	20 ... 30 V AC, 50 Hz:	approx. 0.53 VA
	42 ... 48 V AC, 50 Hz:	approx. 0.53 VA
	100 ... 130 V AC, 50 Hz:	approx. 1.43 VA
Rated voltages:	20 ... 30/42 ... 48/100 ... 130/187 ... 264 V AC	
	50 or 60 Hz, 10 ... 30/36 ... 80/100 ... 130 V DC	
	On time:	100 %
Count mode:	adding	
Height of figures:	4 x 1.7 mm [0.158 x 0.067"]	
Colour of figures:	Hour meter:	
	Hours: white figures on black	
	1/10 and 1/100 h: red figures on black	
	Adding counter: white figures on black	
Operating indicator of the hour meter:		
AC:	fast rotating wheels with red dashes: 99999.9 h	
DC:	1/100 h display turns continuously by 1 digit per 36 s: 999999.9 h	

Accuracy:	AC: Supply frequency + 30 ms DC: < 0.003 % (24 h)
Reset:	no
Ambient temperature:	-15 ... +50 °C [5 ... 122 °F]
Mounting position:	any
Protection:	IP 52 (from front, when built-in)
Colour of housing:	black
Weights:	SHC 77 85 g [2.998 oz]
	SHC 77.60 105 g [3.704 oz]
Options:	SHC 77 The two meters are connected in parallel, this means, that the adding counter registers the total number of events and the time meter the total operating time of the device.
	SHC 77.60 Hour meter and adding counter have two separate connections. This version is available for either AC or DC version (not mixed)
Applications:	switch cabinets, distribution boxes etc.
Test voltage:	2500V AC, 50 Hz
Order information:	Art. no. (for special voltages etc. exact type, voltage, frequency e.g. SHC 77, 120 V AC, 60 Hz)
Approvals:	UL for USA and Canada E128604

Figure.: SHC 77



SHC 77

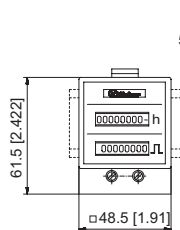

SHC 77.60

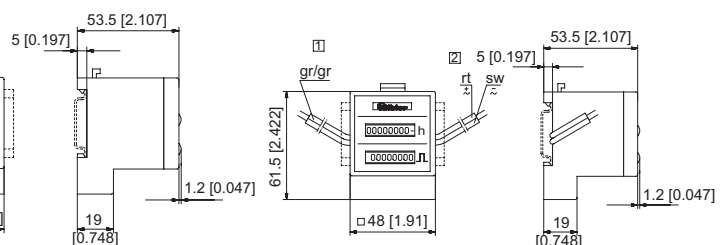

1 Adding counter 2 Hour meter

### SHC 77

Voltage	Art-No. (AC), 50 Hz	Art-No. (AC), 60 Hz	Art-No. (V DC)
10 ... 30			3.553.401.351
20 ... 30	3.553.401.071	3.553.401.081	
36 ... 80			3.553.401.353
42 ... 48	3.553.401.072	3.553.401.082	
100 ... 130	3.553.401.074	3.553.401.084	3.553.401.381
187 ... 264	3.553.401.075	3.553.401.085	

### SHC 77.60 (separate connections)

Voltage	Art-No. (AC), 50 Hz	Art-No. (AC), 60 Hz	Art-No. (V DC)
10 ... 30			3.553.401.351.060
20 ... 30	3.553.401.071.060	3.553.401.081.060	
36 ... 80			3.553.401.353.060
42 ... 48	3.553.401.072.060	3.553.401.082.060	
100 ... 130	3.553.401.074.060	3.553.401.084.060	3.553.401.381.060
187 ... 264	3.553.401.075.060	3.553.401.085.060	

## Energy – Time meter HW 66



Supply voltage AC



Temperature



DIN Front panel



High IP value



no reset



Timer



2 x 6 digit



Energy meter



MID approval - pending

### Innovative:

- Metering of hours run and energy consumption in one compact device
- Wide temperature range
- Panel mounting
- Remote readout via SO outputs on request

### Informative:

- Shows both values in parallel
- Can also be read if no voltage present
- 2 x 6-digit easy-to-read display

### Safe and accurate:

- Tamper-proof fixed installation
- High measuring accuracy
- Can be officially calibrated
- High degree of protection

### Technical data:

#### General

Supply voltage: 115/230 V AC, -20 % / +15 % 50 or 60 Hz single phase (16 A)

Digits: 2 x 6 digit (single units digit red)

Height of figures (optical): 4 x 1.7 mm

Colour of figures: white and red, black ground

Temperature range: -20 to +55 °C

Storage temperature: -25 to +65 °C

Housing: DIN panel-mount 48 x 48 mm, depth 55 mm

Protection: IP 65, DIN 60529 front

Connections: screw terminals touch-safe max. core cross-section 2.5 mm<sup>2</sup>

Connections SO output: screw terminals touch-safe max. core cross-section 2.5 mm<sup>2</sup>

LED function: LED ON, when power supply is connected  
LED blinks, when energy is being measured

#### Energy meter

Accuracy: Class B (1%), acc. to MID (at 50 Hz version)

Current: I<sub>max</sub> = 16 A

Current limits: ≥ 20 mA up to 16 A

Start current: ≥ 20 mA

SO output: 1000 pulses per kWh, 5 ... 30 V DC, I<sub>max</sub> = 20 mA

Standard: EN50470-1, EN50470-3

#### Hour meter

Accuracy: ± 2 %

SO output: 10 pulses/h, 5 ... 30 V DC, I<sub>max</sub> = 20 mA

### Applications:

Dehumidifiers  
Hire equipment and machinery

Air-conditioning  
Production equipment

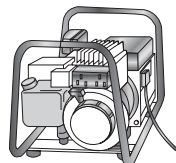
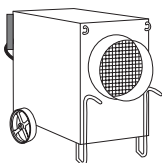

Retro- or standard fitting in dehumidifiers, current generators etc. for the accurate, traceable billing of operating and energy costs

### Order codes:

HW66 230 V AC: 3.563.201.075

HW66 115 V AC: 3.563.201.074

### Delivery includes:

Counter  
Gasket  
Mounting clip

### Dimensions:

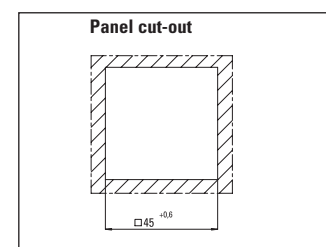
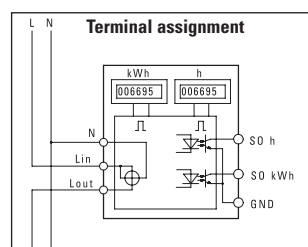
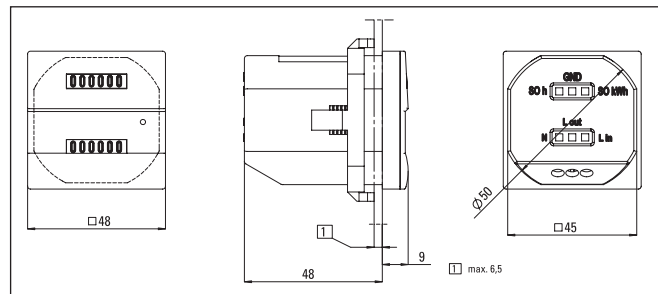

## LCD Display counter **CODIX 130**



- Low-price and high efficiency
- Large 8-digit LCD display, height of the figures 8 mm [0.315"]
- Optional backlighting
- Simple counter for fast and slow count pulses, counting direction switchable via control input
- High voltage input for 10 ... 260 V AC/DC voltage pulses
- Unified Codix design, matches the extensive **CODIX** family
- IP 65
- Screw terminals, RM 5 mm [0.197"]
- Lifetime of the battery approximately 8 years
- Locking of the reset key
- Ambient temperature -10 ... +60 °C [14 ... 140 °F]
- All versions for positive or negative counting edge
- Filter function for bounce-free counting with mechanical contacts.

### Technical data:

Power supply:	non-replaceable lithium battery (lifetime approximately 8 years at 20 °C [68 °F])	<b>Counting inputs:</b>	Counting input of the DC-versions (max. 30 V DC)
Backlighting:	external electrical source 24 V DC +/-20 %, 50 mA	Slow counting input:	max. 30 Hz NPN
Display:	LCD, 8 digits, height of the figures 8 mm [0.315]	Fast counting input:	max. 12 kHz (PNP), 7 kHz (NPN)
Mode:	adding or subtracting (selectable) counting direction differential counting or phase discriminator single or dual evaluation, selectable	Switching level:	NPN: Low: 0 ... 0.7 V, High: 3 ... 30 V DC PNP: Low: 0 ... 0.7 V, High: 4 ... 30 V DC
Display range:	-9999999 ... 99999999, with overflow display	Counting input of the high voltage versions (10 ... 260 V DC/V AC)	Counting input:
Reset:	manual and electrical	Counting input:	Optocoupler input, max. 30 Hz
UL certified:	file: E128604	Min. pulse time:	16 ms
Interference emissions:	EN 55011 Class B, EN 61000-6-2 EN 61010 Section 1 (only AC versions)	Switching level:	Low: 0 ... 2 V DC/V AC, High: 10 ... 260 V DC/V AC
Housing:	dark grey RAL 7021	Counting direction switching (only DC-version)	Mode:
Operating temperature:	-10 ... +55 °C [14 ... 131 °F]	Mode:	see order table
Ambient temperature:	-10 ... +60 °C [14 ... 140 °F]	Contact input:	Open Collector NPN (switching at 0 V DC)
Storage temperature:	-20 ... +70 °C [-4 ... 158 °F]	Switching level:	NPN: Low: 0 ... 0.7 V, High: 3 ... 5 V DC
Protection:	IP 65 front	Reset Input (only DC and high voltage)	Minimum pulse time:
Weight:	approx. 50 g [1.764 oz]	Minimum pulse time:	DC: 50 ms, high voltage: 16 ms
		Contact input DC:	NPN: Low: 0 ... 0.7 V, High: 3 ... 30 V DC
		High voltage input:	10 ... 260 V DC/V AC
		Electrical reset key locking (for DC and AC)	Contact input:
		Contact input:	Open Collector NPN (switching at 0 V)
		Switching level:	NPN: Low: 0 ... 0.7 V, High: 3 ... 5 V DC

## LCD Display counter **CODIX 130**

Connection diagram:

### DC type:

6.130.012.8x0

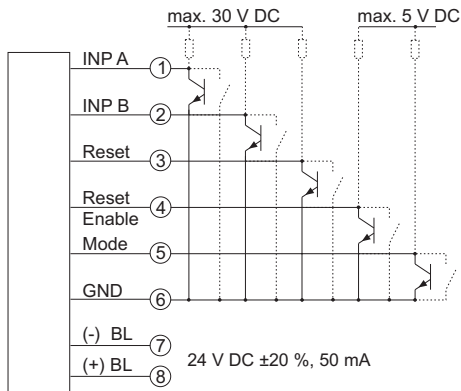

### DC type:

6.130.012.8x2

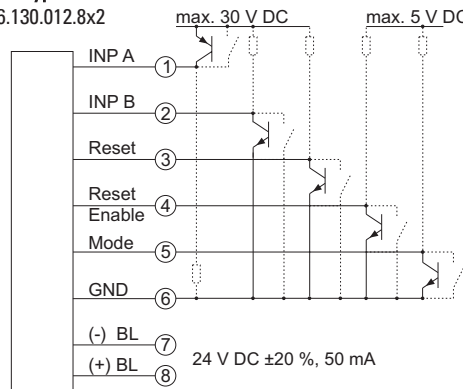

### AC type:

6.130.012.8x3

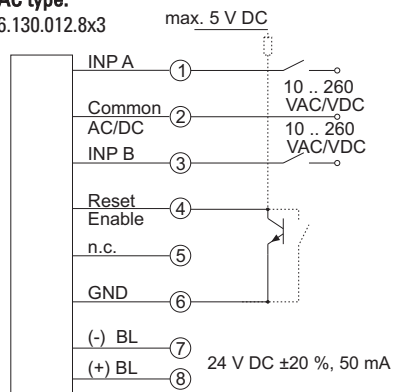

BL = backlight



## LCD Display counter **CODIX 130**

### Dimensions:

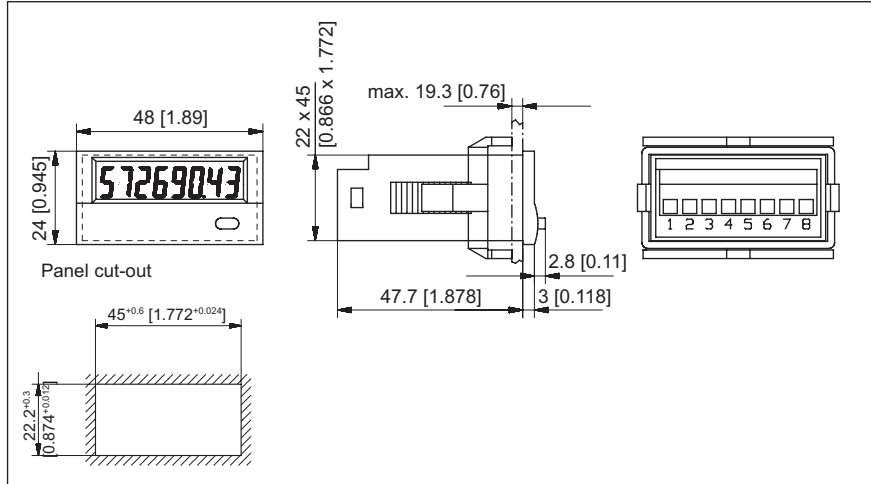

### Dimensions for bezels (included in delivery):

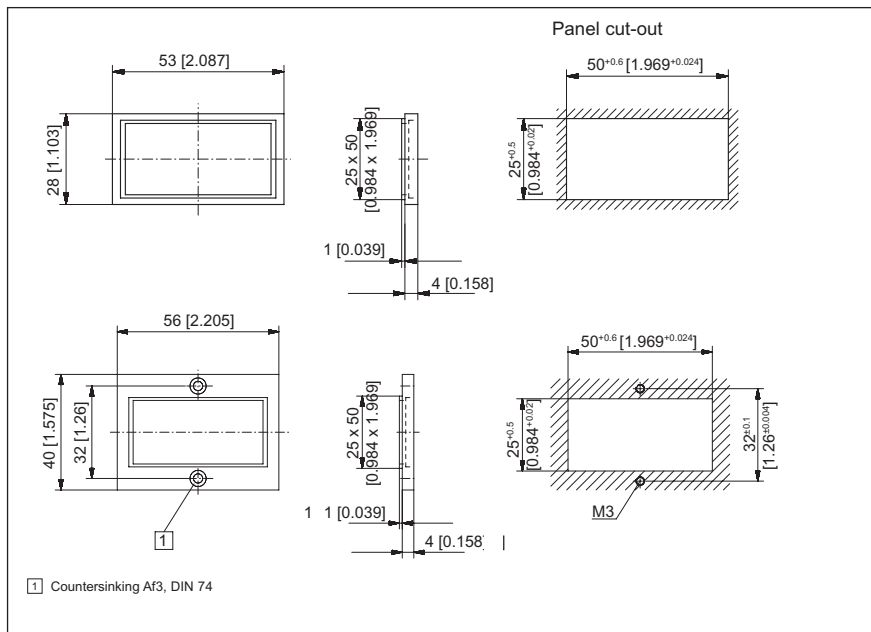

### Delivery specification:

- Digital display
- Panel mounting clip
- Bezel for screw mounting (56 x 40 mm) [2.205 x 1.575"], panel cut out 50 x 25 mm [1.969 x 0.984"]
- Bezel for clip mounting (53 x 28 mm) [2.087 x 1.103"], panel cut out 50 x 25 mm [1.969 x 0.984"]
- Seal
- Operating instructions

### Order information:

Type	Input type	Count input							
		INP A				INP B			
6.130.012.8x0*	Count <sup>1)</sup>	0 ... 0.7 V DC	count	NPN	7 kHz	0 ... 0.7 V DC	count	NPN	30 Hz
6.130.012.8x2*		4 ... 30 V DC	count	PNP	12 kHz	0 ... 0.7 V DC	count	NPN	
6.130.012.8x3*		10 ... 260 V AC/DC	count	AC/DC	30 Hz	10 ... 260 V AC/DC	reset	AC/DC	-

X: 5 = no backlight  
X: 6 = with backlight

1): one-channel, adding or subtracting counting  
\* standard stock model

## LCD Display counter **CODIX 131**



- Low-price and high efficiency
- Large 8-digit LCD display, height of the figures 8 mm [0.315"]
- Optional backlighting
- Various counting modes such as Totalizing, Up/ Down and Difference.
- High voltage input for 10 ... 260 V AC/DC voltage pulses
- Unified Codix design, matches the extensive **CODIX** family
- IP 65
- Screw terminals, RM 5 mm [0.197"]
- Lifetime of the battery approximately 8 years
- Locking of the reset key
- Ambient temperature -10 ... +60 °C [14 °F ... 140 °F]
- All versions for positive or negative counting edge
- Filter function for bounce-free counting with mechanical contacts.

### Technical data:

Power supply:	non-replaceable lithium battery (lifetime approximately 8 years at 20°C [68 °F])
Backlighting:	external electrical source 24 V DC +/- 20 %, 50 mA
Display:	LCD, 8 digits, height of the figures 8 mm [0.315"]
Mode:	adding or subtracting (selectable) counting direction differential counting or phase discriminator single or dual evaluation, selectable
Display range:	-9999999 ... 99999999, with overflow display
Reset:	manual and electrical
UL certified:	File: E128604
Interference emissions:	EN 55011 Class B, EN 61000-6-2 EN 61010 Section 1 (only AC versions)
Housing:	dark grey RAL 7021
Operating temperature:	-10 ... +55 °C [14 ... 131 °F]
Ambient temperature:	-10 ... +60 °C [14 ... 140 °F]
Storage temperature:	-20 ... +70 °C [-4 ... 158 °F]
Protection:	IP 65 front
Weight:	approx. 50 g [1.764 oz]

<b>Counting inputs:</b>	
Counting input of the DC-versions (max. 30 V DC)	
Slow counting input:	max. 30 Hz NPN
Fast counting input:	max. 12 kHz (PNP), 7 kHz (NPN)
Switching level:	NPN: Low: 0 ... 0.7 V, High: 3 ... 30 V DC PNP: Low: 0 ... 0.7 V, High: 4 ... 30 V DC
Counting input of the high voltage versions (10 ... 260 V DC/V AC)	
Counting input:	Optocoupler input, max. 30 Hz
Min. pulse time:	16 ms
Switching level:	Low: 0 ... 2 V DC/V AC, High: 10 ... 260 V DC/V AC
Counting direction switching (only DC-version)	
Mode:	see order table
Contact input:	Open Collector NPN (switching at 0 V DC)
Switching level:	NPN: Low: 0 ... 0.7 V, High: 3 ... 5 V DC
Reset Input (only DC and high voltage)	
Minimum pulse time:	DC: 50 ms, high voltage: 16 ms
Contact input DC:	NPN: Low: 0 ... 0.7 V, High: 3 ... 30 V DC
High voltage input:	10 ... 260 V DC/V AC
Electrical reset key locking (for DC and AC)	
Contact input:	Open Collector NPN (switching at 0 V)
Switching level:	NPN: Low: 0 ... 0.7 V, High: 3 ... 5 V DC

### Connection diagram:

**DC type:**  
6.131.012.8x0

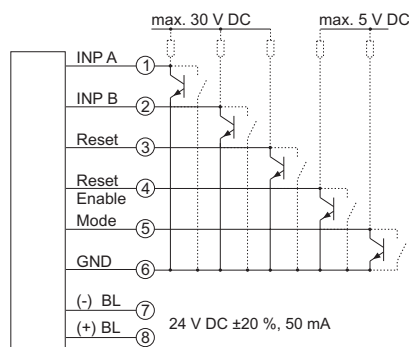

**DC type:**  
6.131.012.8x1

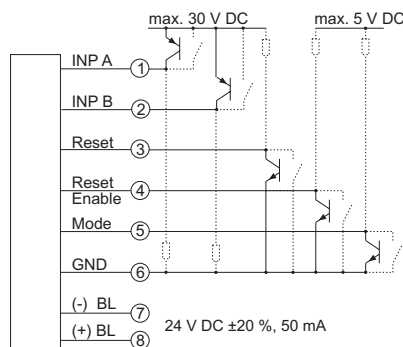

**AC type:**  
6.131.012.8x3

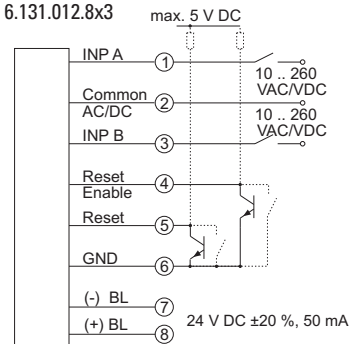

BL = backlight

## LCD Display counter **CODIX 131**

### Dimensions:

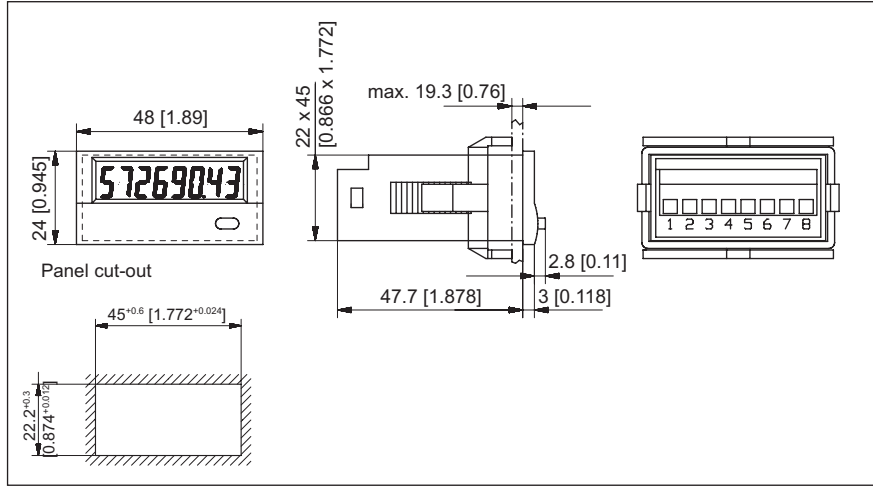

### Dimensions for bezels (included in delivery)

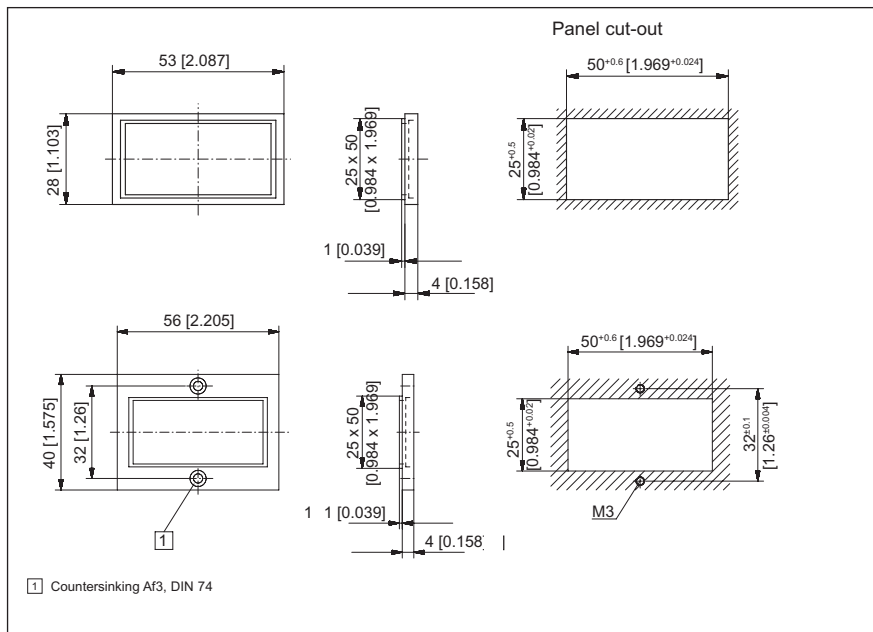

### Delivery specification:

- Digital display
- Panel mounting clip
- Bezel for screw mounting (56 x 40 mm) [2.205 x 1.575"], panel cut out 50 x 25 mm [1.969 x 0.984"]
- Bezel for clip mounting (53 x 28 mm) [2.087 x 1.103"], panel cut out 50 x 25 mm [1.969 x 0.984"]
- Seal
- Operating instructions

### Order information:

Type	Input type	Count inputs							
		INP A				INP B			
6.131.012.8x0*	Cnt.Dir <sup>2)</sup> /Up.Dn <sup>3)</sup>	0 ... 0,7 V DC	count	NPN	7 kHz	0 ... 0,7 V DC	count/direction	NPN	7 kHz
6.131.012.8x1*		4 ... 30 V DC	count	PNP	12 kHz	4 ... 30 V DC	count/direction	PNP	12 kHz
6.131.012.8x3*	Up.Dn <sup>3)</sup>	10 ... 260 V AC/DC	count	AC/DC	30 Hz	10 ... 260 V AC/DC	count	AC/DC	30 Hz

X: 5 = no backlight  
X: 6 = with backlight

2): counting input with counting direction input  
3): one adding and one subtracting counting input (differential mode)

\* standard stock model

## LCD Display counter **CODIX 132**



- Low-price and high efficiency
- Large 8-digit LCD display, height of the figures 8 mm [0.315"]
- Optional backlighting
- Counting mode up /down,
- High voltage input for 10 ... 260 V AC/DC voltage pulses
- Unified Codix design, matches the extensive **CODIX** family
- IP 65
- Screw terminals, RM 5 mm [0.197"]
- Lifetime of the battery approximately 8 years
- Locking of the reset key
- Ambient temperature -10 ... +60 °C [14 ... 140 °F]
- All versions for positive or negative counting edge
- Filter function for bounce-free counting with mechanical contacts.

### Technical data:

Power supply:	non-replaceable lithium battery (lifetime approximately 8 years at 20 °C [68 °F])	Protection:	IP 65 front side
Backlighting:	external electrical source 24 V DC +/-20 %, 50 mA	Weight:	approx. 50 g [1.764 oz]
Display:	LCD, 8 digits, height of the figures 8 mm [0.315"]	<b>Counting inputs:</b>	
Mode:	adding or subtracting (selectable) counting direction differential counting or phase discriminator single or dual evaluation, selectable	Counting input of the high voltage versions (10 ... 260 V DC/V AC)	
Display range:	-9999999 ... 99999999, with overflow display	Counting input:	Optocoupler input, max. 30 Hz
Reset:	manual and electrical	Min. pulse time:	16 ms
UL certified:	File: E128604	Switching level:	Low: 0 ... 2 V DC/V AC, High: 10 ... 260 V DC/V AC
Interference emissions:	EN 55011 Class B, EN 61000-6-2 EN 61010 Section 1 (only AC versions)	Reset Input (only DC and high voltage)	
Housing:	dark grey RAL 7021	Minimum pulse time:	DC: 50 ms, high voltage: 16 ms
Operating temperature:	-10 ... +55 °C [14 ... 131 °F]	Contact input DC:	NPN: Low: 0 ... 0.7 V, High: 3 ... 30 V DC
Ambient temperature:	-10 ... +60 °C [14 ... 140 °F]	High voltage input:	10 ... 260 V DC/V AC
Storage temperature:	-20 ... +70 °C [-4 ... 158 °F]	Electrical reset key locking (for DC and AC)	
		Contact input:	Open Collector NPN (switching at 0 V)
		Switching level:	NPN: Low: 0 ... 0.7 V, High: 3 ... 5 V DC

### Connection diagram:

AC type:  
6.132.012.8x3

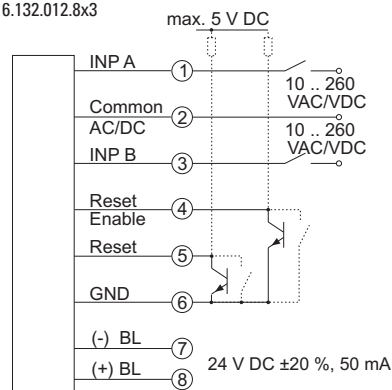

BL = backlight

## LCD Display counter **CODIX 132**

### Dimensions:

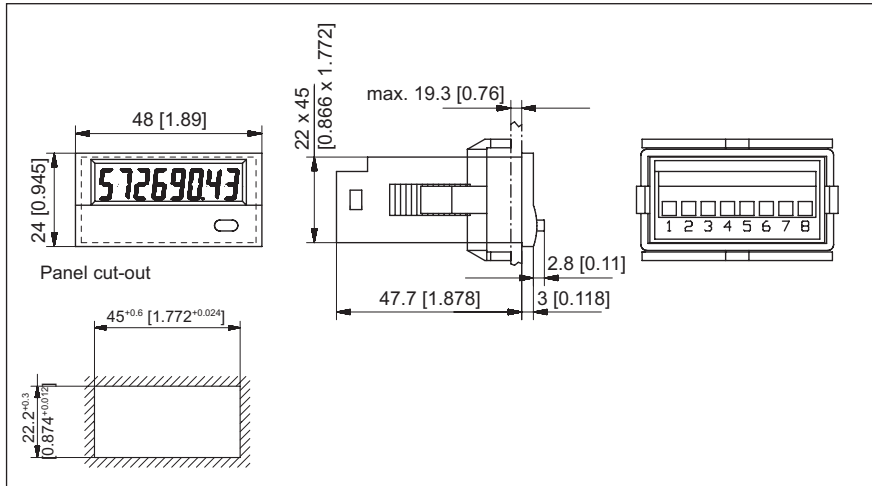

### Dimensions for bezels (included in delivery)

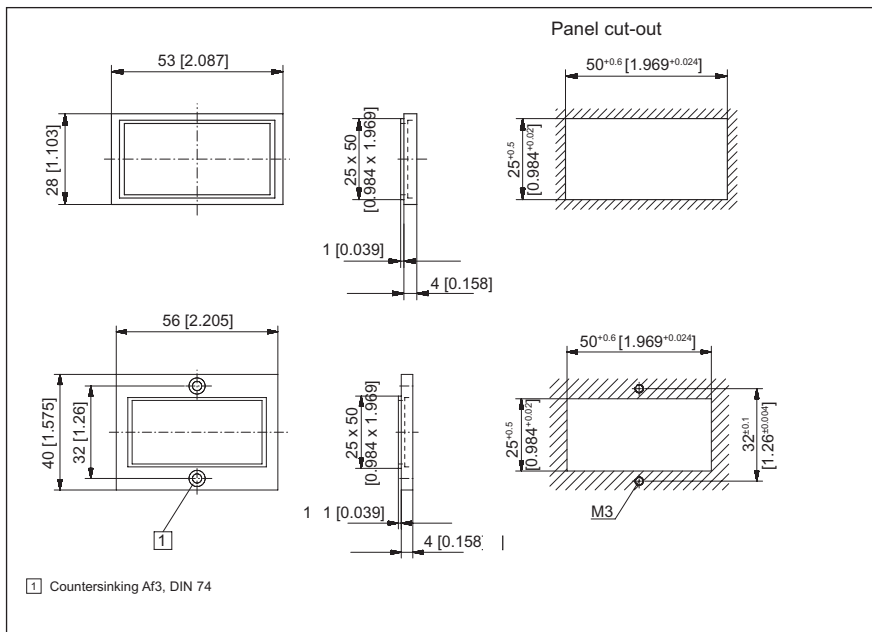

### Delivery specification:

- Digital display
- Panel mounting clip
- Bezel for screw mounting (56 x 40 mm) [2.205 x 1.575"], panel cut out 50 x 25 mm [1.969 x 0.984"]
- Bezel for clip mounting (53 x 28 mm) [2.087 x 1.103"], panel cut out 50 x 25 mm [1.969 x 0.984"]
- Seal
- Operating instructions

### Order information:

Type	Input type	Count inputs							
		INP A				INP B			
6.132.012.8x3*	Cnt.Dir <sup>2)</sup>	10 ... 260 V AC/DC	direction	AC/DC	30 Hz	10 ... 260 V AC/DC	count	AC/DC	30 Hz

X: 5 = no backlight  
X: 6 = with backlight

2): counting input with counting direction input  
\* standard stock model

## LCD Display counter **CODIX 133**



- Low-price and high efficiency
- Large 8-digit LCD display, height of the figures 8 mm [0.315"]
- Optional backlighting
- Counting modes include phase discriminator (quadrature) counting (also with pulse doubling) for connection to incremental encoders
- Unified Codix design, matches the extensive **CODIX** family
- IP 65
- Screw terminals, RM 5 mm [0.197"]
- Lifetime of the battery approximately 8 years
- Locking of the reset key
- Ambient temperature -10 ... +60 °C [14 ... 140 °F]
- All versions for positive or negative counting edge

### Technical data:

Power supply:	non-replaceable lithium battery (lifetime approximately 8 years at 20 °C [68 °F])
Backlighting:	external electrical source 24 V DC +/-20 %, 50 mA
Display:	LCD, 8 digits, height of the figures 8 mm [0.315"]
Mode:	adding or subtracting (selectable) counting direction differential counting or phase discriminator single or dual evaluation, selectable
Display range:	-9999999 ... 99999999, with overflow display
Reset:	manual and electrical
UL certified:	File: E128604
Interference emissions:	EN 55011 Class B, EN 61000-6-2 EN 61010 Section 1 (only AC versions)
Housing:	dark grey RAL 7021
Operating temperature:	-10 ... +55 °C [14 ... 131 °F]
Ambient temperature:	-10 ... +60 °C [14 ... 140 °F]
Storage temperature:	-20 ... +70 °C [-4 ... 158 °F]
Protection:	IP 65 front side
Weight:	approx. 50 g [1.764 oz]

<b>Counting inputs:</b>	
Counting input of the DC-versions (max. 30 V DC)	
Slow counting input:	max. 30 Hz NPN
Fast counting input:	max. 12 kHz (PNP), 7 kHz (NPN)
Switching level:	NPN: Low: 0 ... 0.7 V, High: 3 ... 30 V DC PNP: Low: 0 ... 0.7 V, High: 4 ... 30 V DC
Switching	x1 or x2 evaluation
Contact input:	Open Collector NPN (switching at 0 V DC)
Switching level:	NPN: Low: 0 ... 0.7 V, High: 3 ... 5 V DC
Reset Input (only DC and high voltage)	
Minimum pulse time:	DC: 50 ms, high voltage: 16 ms
Contact input DC:	NPN: Low: 0 ... 0.7 V, High: 3 ... 30 V DC
Electrical reset key locking (for DC and AC)	
Contact input:	Open Collector NPN (switching at 0 V)
Switching level:	NPN: Low: 0 ... 0.7 V, High: 3 ... 5 V DC

### Connection diagram:

**DC type:**  
6.133.012.8x0

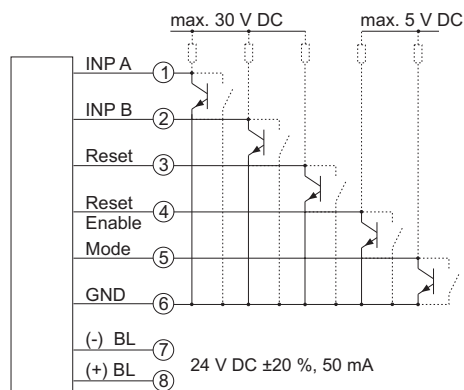

**DC type:**  
6.133.012.8x1

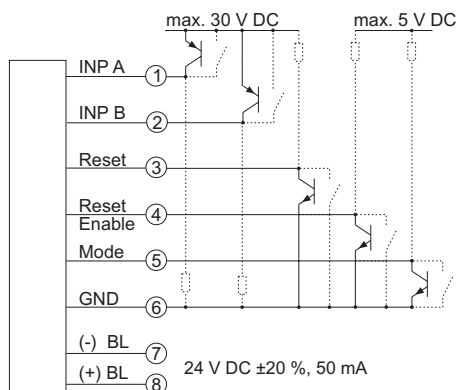

## LCD Display counter **CODIX 133**

### Dimensions:

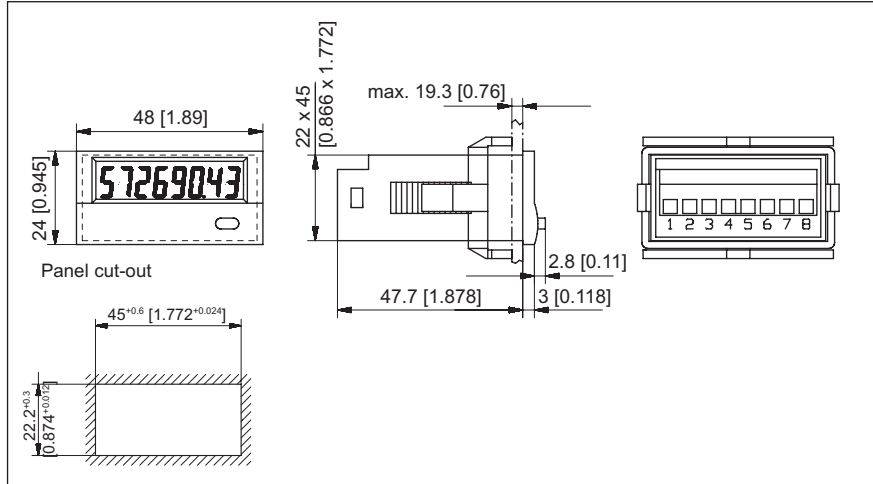

### Dimensions for bezels (included in delivery)

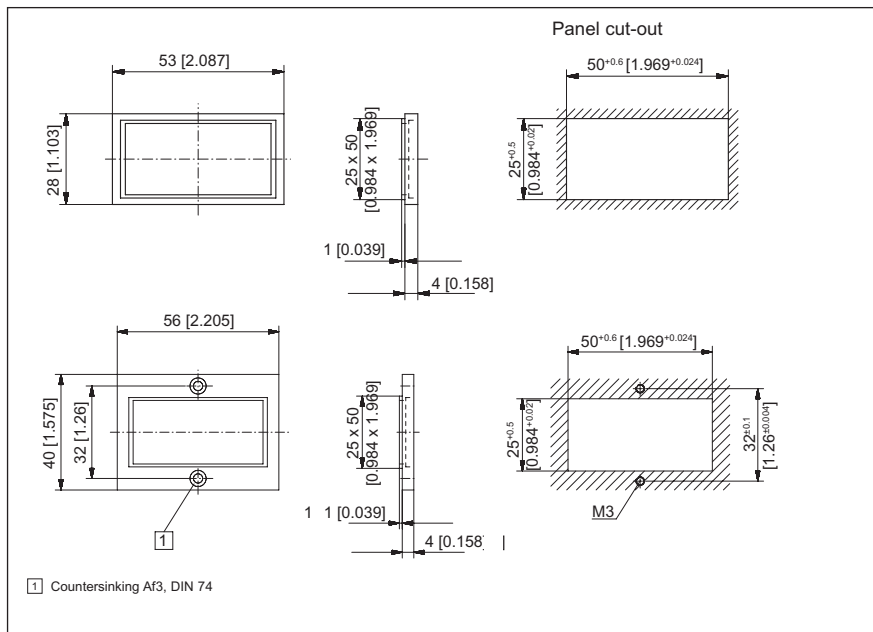

### Delivery specification:

- Digital display
- Panel mounting clip
- Bezel for screw mounting (56 x 40 mm) [2.205 x 1.575"], panel cut out 50 x 25 mm [1.969 x 0.984"]
- Bezel for clip mounting (53 x 28 mm) [2.087 x 1.103"], panel cut out 50 x 25 mm [1.969 x 0.984"]
- Seal
- Operating instructions

### Order information:

Type	Input type	Count inputs							
		INP A				INP B			
6.133.012.8x0*	Quad <sup>4</sup> /Quad <sup>25</sup>	0 ... 0.7 V DC	channel A	NPN	3 kHz	0 ... 0.7 V DC	channel B	NPN	3 kHz
6.133.012.8x1*		4 ... 30 V DC	channel A	PNP	6 kHz	4 ... 30 V DC	channel B	PNP	6 kHz

X: 5 = no backlight  
X: 6 = with backlight

4) Phase discriminator for incremental encoders with x1 evaluation

5) Phase discriminator for incremental encoders with x2 evaluation  
\* standard stock model

## Totaliser **CODIX 520**

- Simple programmable pulse counter Codix 520
- Single channel totaliser



Power supply  
DC



Front bezel  
dimensions

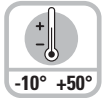

Wide temper-  
ature range



High IP  
protection  
rating



Menu-driven  
programming



Operation  
with gloves



Input type

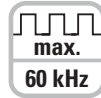

Pulse counter/  
Totaliser

### Powerful

- **Fast count input**  
Input frequency max. 60 kHz
- **Robust housing**  
IP 65 protection
- **LED display**  
Very bright, 8 mm high
- **Simple totalizing and quantity counters**  
Single channel count input and reset input  
Programmable for positive (PNP) or negative (NPN) switching input pulses  
Fast count input with an input frequency of max. 60 kHz, can be damped to 30 Hz for mechanical contacts
- **Fast start-up time**  
Detects incoming pulses just 16 ms after being switched on – so no pulses are lost with a simultaneous motor start-up



### User-friendly

- **Big keys**  
Can also be operated when using gloves
- **Easy to programme**  
Easy menu-driven programming and operation  
Possibility to enter the programming mode during operation, with authentication query

### Universal

- **Programmable decimal point**  
Can be set between 0.0 and 0.000
- **Manual or electrical reset**  
Tamper-proof, due to lockable reset function
- **DC power supply**
- **Inputs**  
As an alternative to the HTL inputs, devices with a 5 VDC input trigger level are available, for use as parallel displays for PLCs

### Applications for Pulse Counters/ Totalisers

- Simple count tasks such as quantity and piece counting
- Accessories, OEM equipment or retrofitting to production machines
- Piece counting on die cutters, presses, extruders, woodworking machines, drilling machines, pick-and-place machines, guillotines, special-purpose vehicles etc.

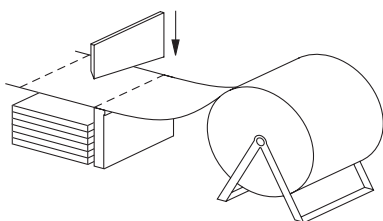

Piece-counting

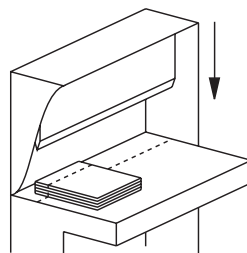

Number of cuts

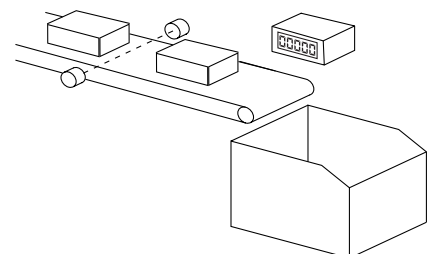

Piece-counting on conveyor



## Totaliser **CODIX 520**

### Technical data:

Supply voltage:	10 ... 30 V DC, with reverse polarity protection	Level of inputs:	Low: 0 ... 0.2 x U <sub>B</sub> [V DC] High: 0.6 x U <sub>B</sub> ... 30 V DC
Current consumption:	max. 40 mA	Level of inputs:	Low: 0 ... 2 V DC High: 4 ... 30 V DC
Display:	6-digit red 7-segment LED; 8 mm [0.315"] high	5 V version	High: 4 ... 30 V DC
Data backup:	EEPROM	EMC:	according to EC EMC directive 89/36/EWG
Housing:	dimension 48 x 24 mm [1.89 x 0.945"] according to DIN 43 700; RAL 7021, grey	Immunity to interference:	EN 61000-6-4/EN 55011 class B
Polarity of inputs:	programmable, npn or pnp for all inputs	Emitted interference:	EN 61000-6-2
Input resistance:	approx. 5 kΩ	Ambient temperature:	-10 ... +50 °C [14 ... 122 °F]
Counting frequency:	60 kHz, can be damped to 30 Hz	Storage temperature:	-25 ... +70 °C [-13 ... 158 °F]
Reset time:	5 ms	Protection:	IP 65 front side
		Weight:	approx. 50 g [1.764 oz]

### Block diagram:

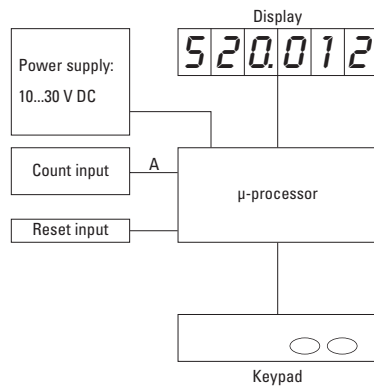

### Dimensions:

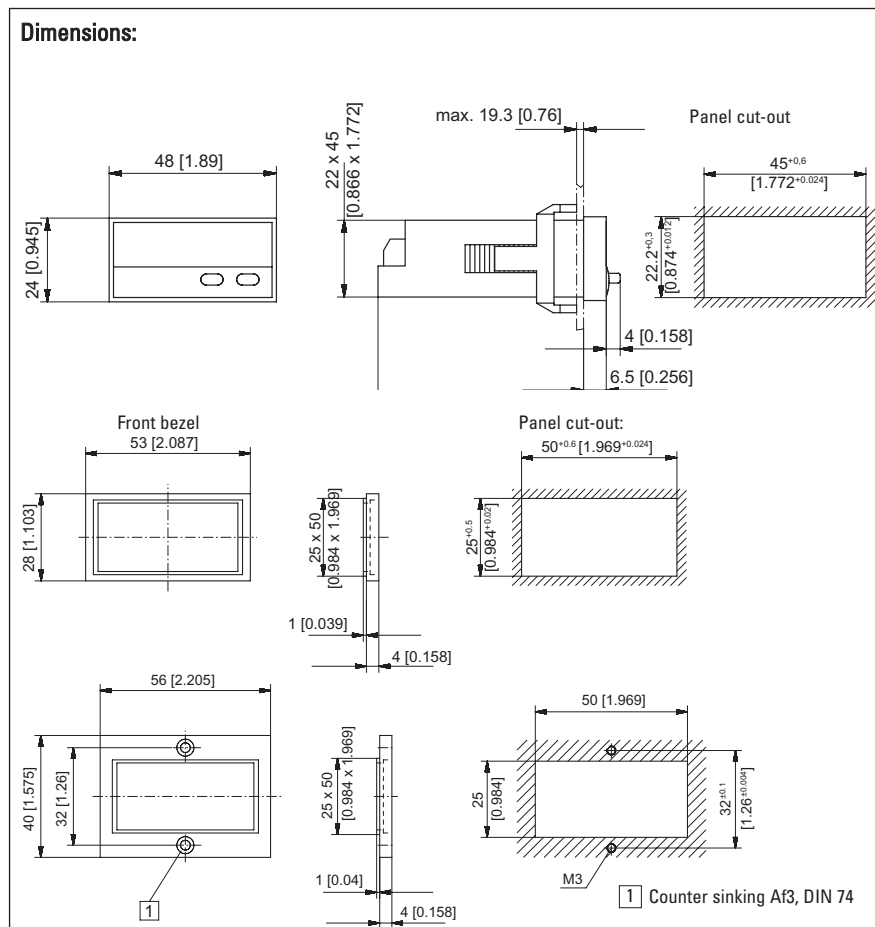

### Connections:

- 1 10 ... 30 VDC
- 2 0 V GND
- 3 INP
- 4 -
- 5 Reset

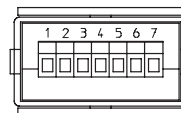

### Delivery specifications:

- 1 Digital display
- 1 Panel mounting clip
- 1 Bezel for screw mounting, panel cut out 50 x 25 mm [1.969 x 0.984"]
- 1 Bezel for clip mounting, panel cut out 50 x 25 mm [1.969 x 0.984"]
- 1 Seal
- 1 Multilingual operating instructions

### Order code:

6.520.012.3X0

Input switch level  
0 = Standard\*  
A = 5 V level

\* standard stock model

## Position indicator or totaliser **CODIX 521**

### 4 count modes:

- Count with direction
- Count difference
- Count sum of 2 inputs
- Phase discriminator (quadrature) x1, x2 and x4

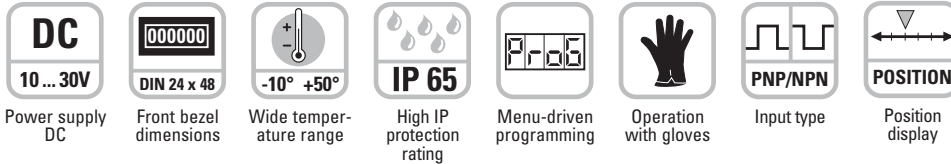

### Powerful

- **Fast count input**  
Input frequency max. 60 kHz
- **Robust housing**  
IP 65 protection
- **LED display**  
Very bright, 8 mm high
- **Position, difference, adding or detection of count direction**  
Programmable for positive (PNP) or negative (NPN) switching input pulses  
Fast count input with an input frequency of max. 60 kHz, can be damped to 30 Hz for mechanical contacts
- **Fast start-up time**  
Detects incoming pulses just 16 ms after being switched on – so no pulses are lost with a simultaneous motor start-up



### User-friendly

- **Big keys**  
Can also be operated when using gloves
- **Easy to programme**  
Easy menu-driven programming and operation  
Possibility to enter the programming mode during operation, with authentication query

### Universal

- **Individually programmable scaling**  
Multiplication and division factor (0.0001 to 99.9999), to display corresponding engineering units, e.g. position in 1/10 mm and speed in RPM
- **4 different count input modes**  
2-channel input for detecting count direction, difference or adding mode, quadrature x1, x2 or x4
- **Programmable setpoint**
- **DC power supply**
- **Inputs**  
As an alternative to the HTL inputs, devices with a 5 VDC input trigger level are available, for use as parallel displays for PLCs.
- **Optional output**  
As zero signal

## Applications for Position Displays and Totalisers

- Positioning tasks on processing machines, such as sawing machines, milling machines, bending and folding machines, etc.
- Production data acquisition by means of piece counting (using difference or adding)
- Totalizing flow, quantity and other scaleable media
- Counting tasks such as quantity and piece counting
- Accessories, OEM equipment or retrofitting to production machines
- Piece counting on die cutters, presses, extruders, woodworking machines, drilling machines, pick-and-place machines, guillotines, special-purpose vehicles etc.

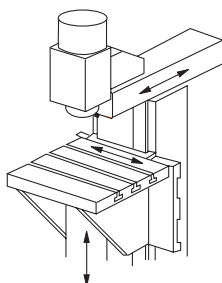

Position on milling machine

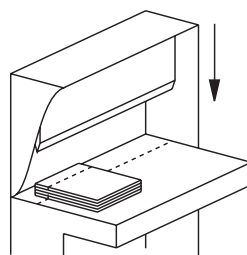

Position or quantity

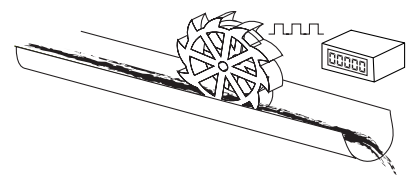

Flow rate

## Position indicator or totaliser **CODIX 521**

### Technical data:

Supply voltage:	10 ... 30 V DC, with reverse polarity protection	Level of inputs:	Low: 0 ... 0.2 x U <sub>B</sub> [V DC] High: 0.6 x U <sub>B</sub> ... 30 V DC
Current consumption:	max. 50 mA	Level of inputs:	Low: 0 ... 2 V DC High: 4 ... 30 V DC
Display:	6 digit red 7-segment LED; 8 mm [0.315"] high	5 V version	High: 4 ... 30 V DC
Data backup:	EEPROM	Optocoupler output:	Max. 30 V, 10 mA
Housing:	Dimension 48 x 24 mm [1.89 x 0.945"] according to DIN 43 700; RAL 7021, grey	EMC:	according to EC EMC directive 89/36/EWG
Polarity of inputs:	programmable, npn or pnp for all inputs	Immunity to interference:	EN 61000-6-4/EN 55011 class B
Input resistance:	approx. 5 kΩ	Emitted interference:	EN 61000-6-2
Counting frequency:	60 kHz, can be damped to 30 Hz	Ambient temperature:	-10 ... +50 °C [14 ... 122 °F]
Reset time:	5 ms	Storage temperature:	-25 ... +70 °C [-13 ... 158 °F]
		Protection:	IP65 front side
		Weight:	approx. 50 g [1.764 oz]

### Block diagram:

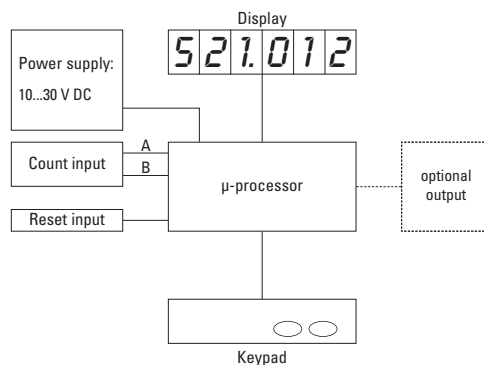

### Dimensions:

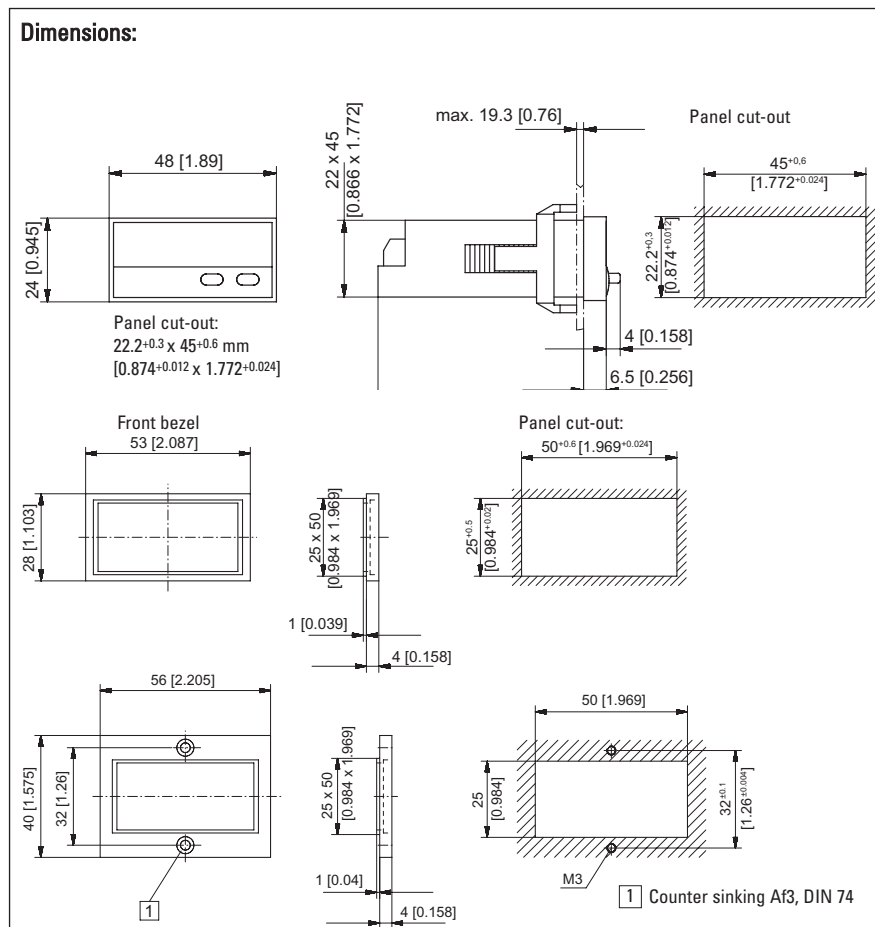

### Connections:

without optocoupler

- 1 10 ... 30 V DC
- 2 0 V GND
- 3 INP A
- 4 INP B
- 5 Reset



### Connections:

with optocoupler

- 1 10 ... 30 V DC
- 2 0 V GND
- 3 INP A
- 4 INP B
- 5 RESET
- 6 Emitter
- 7 Collector

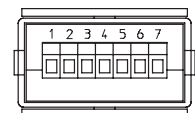

### Delivery specifications:

- 1 Digital display
- 1 Panel mounting clip
- 1 Bezel for screw mounting, panel cut out 50 x 25 mm [1.969 x 0.984"]
- 1 Bezel for clip mounting, panel cut out 50 x 25 mm [1.969 x 0.984"]
- 1 Seal
- 1 Multilingual operating instructions

### Order code:

6.521.01X.3X0

- Input switch level
- 0 = Standard\*
- A = 5 V
- Output
- 1 = Optocoupler
- 2 = No output

\* standard stock model

## Multifunction display **CODIX 524**

programmable as:

- Pulse counter
- Position display
- Frequency / speed display
- Timer/ short time meter

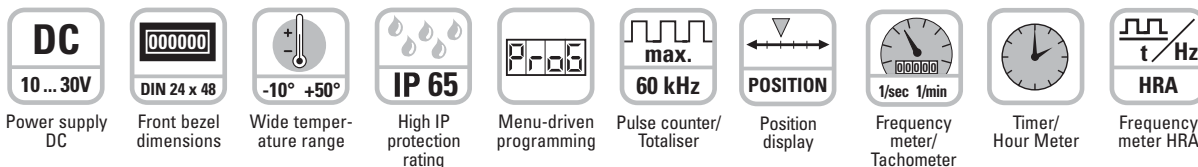

### Powerful

- **Fast count input**  
Input frequency max. 60 kHz
- **Robust housing**  
IP 65 protection
- **LED display**  
Very bright, 8 mm high
- **HRA – High Rate Accuracy System**  
Frequencies up to 38 Hz are calculated using time-interval (period duration) measurement.  
Frequencies > 38 Hz are calculated using a special time base (gate time) measurement. A very high accuracy of > 0.1% is achieved, even with very short gate times. The resulting measurement is available after a max. of 50 ms.
- **Fast start-up time**  
Detects incoming pulses just 16 ms after being switched on – so no pulses are lost with a simultaneous motor start-up



### User-friendly

- **Big keys**  
Can also be operated when using gloves
- **Easy to programme**  
Easy menu-driven programming and operation  
Possibility to enter the programming mode during operation, with authentication query

### Universal

- **Individually programmable scaling**  
Multiplication and division factor (0.0001 to 99.9999), to display corresponding engineering units, e.g. position in 1/10 mm and speed in RPM
- **4 different count input modes**  
2-channel input for detecting count direction, difference or adding mode, quadrature x1, x2 or x4
- **Frequency measurement**  
Display in 1/min or 1/sec
- **Time counting**  
Pulse width or time interval measurement in hours, minutes or seconds, as well as real-time display
- **DC power supply**
- **Inputs**  
As an alternative to the HTL inputs, devices with a 5 VDC input trigger level are available, for use as parallel displays for PLCs.
- **Optional output**  
Zero signal for position and count, zero-speed monitoring, 1 Hz clock pulse for active time measurement

### Applications for Multi-function Display

- Counting tasks such as quantity and piece counting, measuring and recording of speed and of operating and processing times
- Piece counting or tool-life measurement on die cutters, presses, extruders, wood-working machines, drilling machines,

- pick-and-place machines, guillotines, special-purpose vehicles etc.
- Positioning tasks on processing machines, such as sawing machines, milling machines, bending and folding machines, etc.

- Production data acquisition by means of piece counting (using difference or adding), or measurement of production times or production speeds
- Totalizing flow, quantity and other scaleable media, or display of current flow rates

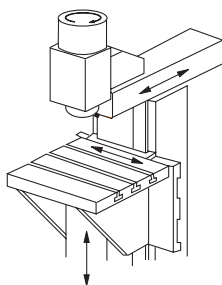

Position or rotary speed on milling machine

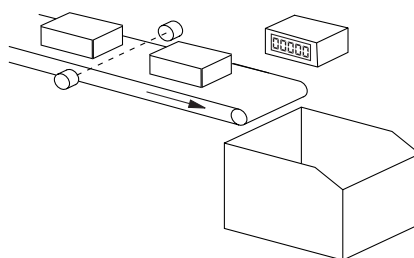

Piece count on conveyor or production speed

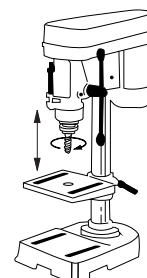

Drilling machine head, speed or drilling depth

## Multifunction display *CODIX 524*

### Technical data:

Supply voltage:	10 ... 30 V DC, with reverse polarity protection	Level of inputs:	Low: 0 ... 0.2 x U <sub>B</sub> [V DC] High: 0.6 x U <sub>B</sub> ... 30 V DC
Current consumption:	max. 50 mA	Level of inputs:	Low: 0 ... 2 V DC
Display:	6 digit red 7-segment LED; 8 mm [0.315"] high	5 V version:	High: 4 ... 30 V DC
Data backup:	EEPROM	Optocoupler output:	Max. 30 V, 10 mA
Housing:	dimension 48 x 24 mm [1.89 x 0.945"] according to DIN 43 700; RAL 7021, grey	Accuracy:	tachometer: <0.1 % timer: 50 ppm
Polarity of inputs:	programmable, npn or pnp for all inputs	EMC:	according to EC EMC directive 89/36/EWG
Input resistance:	approx. 5 kΩ	Immunity to interference:	EN 61000-6-4/EN 55011 class B
Counting frequency:	60 kHz, can be damped to 30 Hz	Emitted interference:	EN 61000-6-2
Display range timer:	0.001 s ... 999999 h	Ambient temperature:	-10 ... +50 °C [14 ... 122 °F]
Reset time:	5 ms	Storage temperature:	-25 ... +70 °C [-13 ... 158 °F]
		Protection:	IP 65 front side
		Weight:	approx. 50 g [1.764 oz]

### Block diagram:

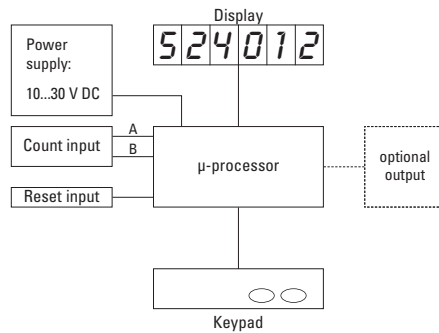

### Dimensions:

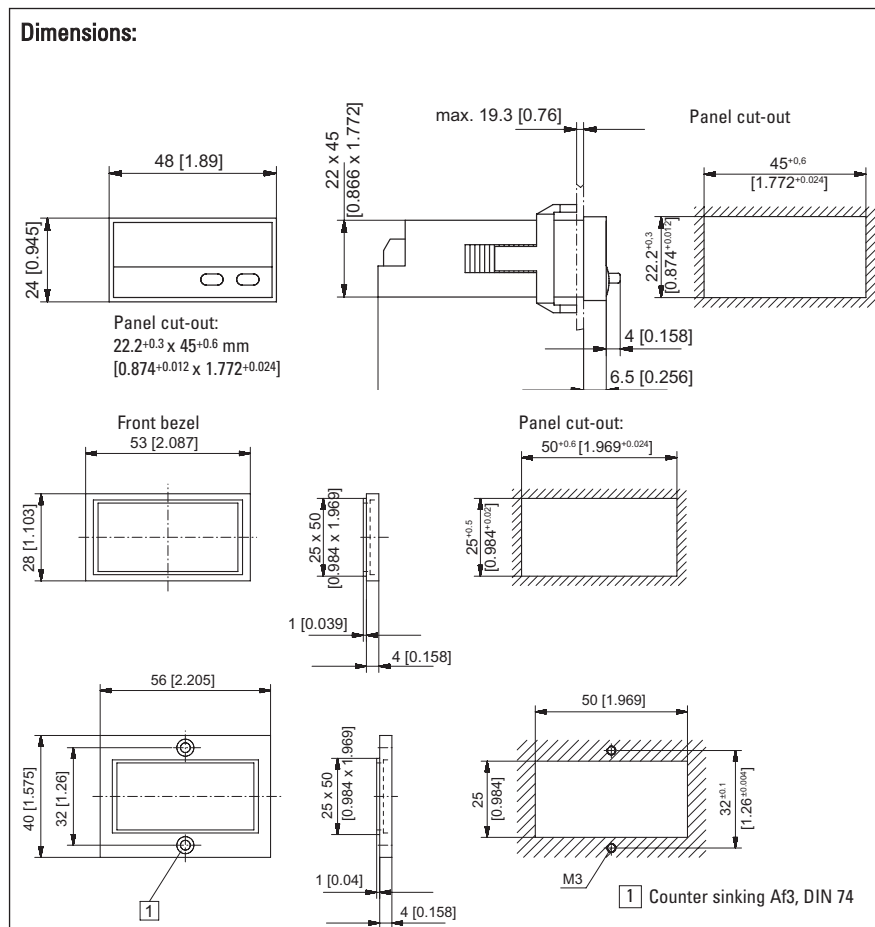

### Connections:

without optocoupler

- 1 10 ... 30 V DC
- 2 0 V GND
- 3 INP A
- 4 INP B
- 5 Reset

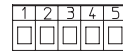

### Connections:

with optocoupler

- 1 10 ... 30 V DC
- 2 0 V GND
- 3 INP A
- 4 INP B
- 5 RESET
- 6 Emitter
- 7 Collector

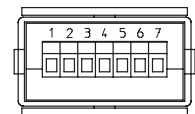

### Delivery specifications:

- 1 Digital display
- 1 Panel mounting clip
- 1 Bezel for screw mounting, panel cut out 50 x 25 mm [ 1.969 x 0.984"]
- 1 Bezel for clip mounting, panel cut out 50 x 25 mm [1.969 x 0.984"]
- 1 Seal
- 1 Multilingual operating instructions

### Order code:

6.524.01X.3X0

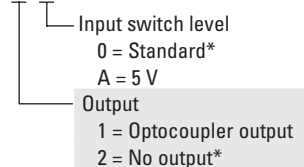

\* standard stock model

## Universal with dual functions **CODIX 52U**

**4 dual functions in one device**  
 > solves all applications where 2 different values must be displayed simultaneously.

- Counter with 2 totalizing ranges
- Totaliser and time counter
- Totaliser and frequency counter
- Timer with 2 time ranges

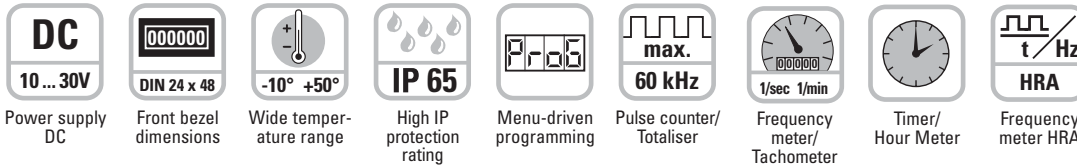

### Powerful

- **Fast count input**  
Input frequency max. 60 kHz
- **Robust housing**  
IP 65 protection
- **LED display**  
Very bright, 8 mm high
- **HRA – High Rate Accuracy System**  
Frequencies up to 38 Hz are calculated using time-interval (period duration) measurement.  
Frequencies > 38 Hz are calculated using a special time base (gate time) measurement. A very high accuracy of > 0.1% is achieved, even with very short gate times. The resulting measurement is available after a max. of 50 ms.
- **Fast start-up time**  
Detects incoming pulses just 16 ms after being switched on – so no pulses are lost with a simultaneous motor start-up



### User-friendly

- **Big keys**  
Can also be operated when using gloves
- **Easy to programme**  
Easy menu-driven programming and operation  
Possibility to enter the programming mode during operation, with authentication query  
Pressing the right key switches between displays

### Universal

- **Individually programmable scaling**  
Multiplication and division factor (0.0001 to 99.9999), to display corresponding engineering units, e.g. position in 1/10 mm and speed in RPM.
- **Separate factors for frequency- and pulse counting**
- **DC power supply**
- **Inputs**  
As an alternative to the HTL inputs, devices with a 5 VDC input trigger level are available, for use as parallel displays for PLCs
- **Timer specials**  
Timer or hours-run meter with various Start Stop measurements, time range settings in hours, minutes or seconds, with decimal point. Resolutions up to 1/1000 can be programmed

### Applications for dual functions

- **Pulse and frequency (speed)**  
e.g. production data acquisition: total piece count and speed on OEM equipment, flow rate measuring systems – total flow and current flow
- **2 pulse counters**  
Measurement of batch and total piece count, or of daily production count and total count values

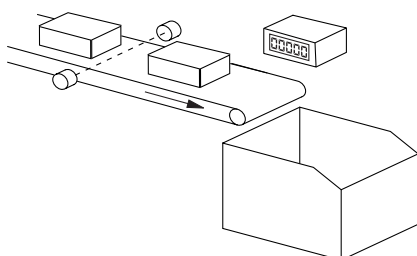

Piece count on conveyor and production speed

- **Pulse and time (Maintenance counter)**  
Used in the lift industry as trip counters and hours-run meters and on production machines for piece and time counting, flow and time measurement, materials handling time and quantities

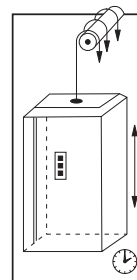

Trip counter and hours-run

- **2 timers**  
Measurement of total time and order-specific times, maintenance intervals and total time, time of day and total time.

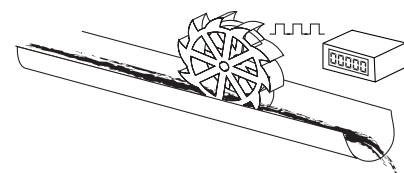

Flow rate and total volume

## Universal with dual functions **CODIX 52U**

### Technical data:

Supply voltage:	10 ... 30 V DC, with reverse polarity protection	Level of inputs:	Low: 0 ... 0.2 x U <sub>B</sub> [V DC] High: 0.6 x U <sub>B</sub> ... 30 V DC
Current consumption:	max. 40 mA	Level of inputs: 5 V version	Low: 0 ... 2 V DC High: 4 ... 30 V DC
Display:	6-digit red 7-segment LED; 8 mm [0.315"] high	Optocoupler output:	Max. 30 V, 10 mA
Data backup:	EEPROM	Accuracy:	<0.1 % (Frequency display, tachometer)
Housing:	dimension 48 x 24 mm [1.89 x 0.945"] according to DIN 43 700; RAL 7021, grey	EMC:	according to EC EMC directive 89/36/EWG
Polarity of inputs:	programmable, npn or pnp for all inputs	Immunity to interference:	EN 61000-6-4/EN 55011 class B
Input resistance:	approx. 5 kΩ	Emitted interference:	EN 61000-6-2
Display range:	0.001 s ... 999999 h	Ambient temperature:	-10 ... +50 °C [14 ... 122 °F]
Reset time:	5 ms	Storage temperature:	-25 ... +70 °C [-13 ... 158 °F]
		Protection:	IP 65 front side
		Weight:	approx. 50 g [1.764 oz]

### Block diagram:

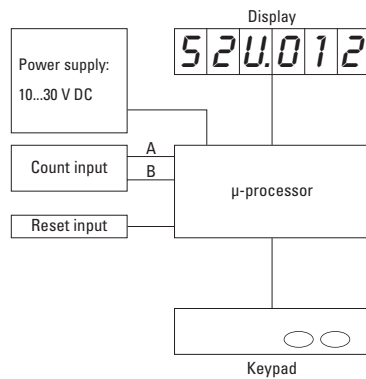

### Dimensions:

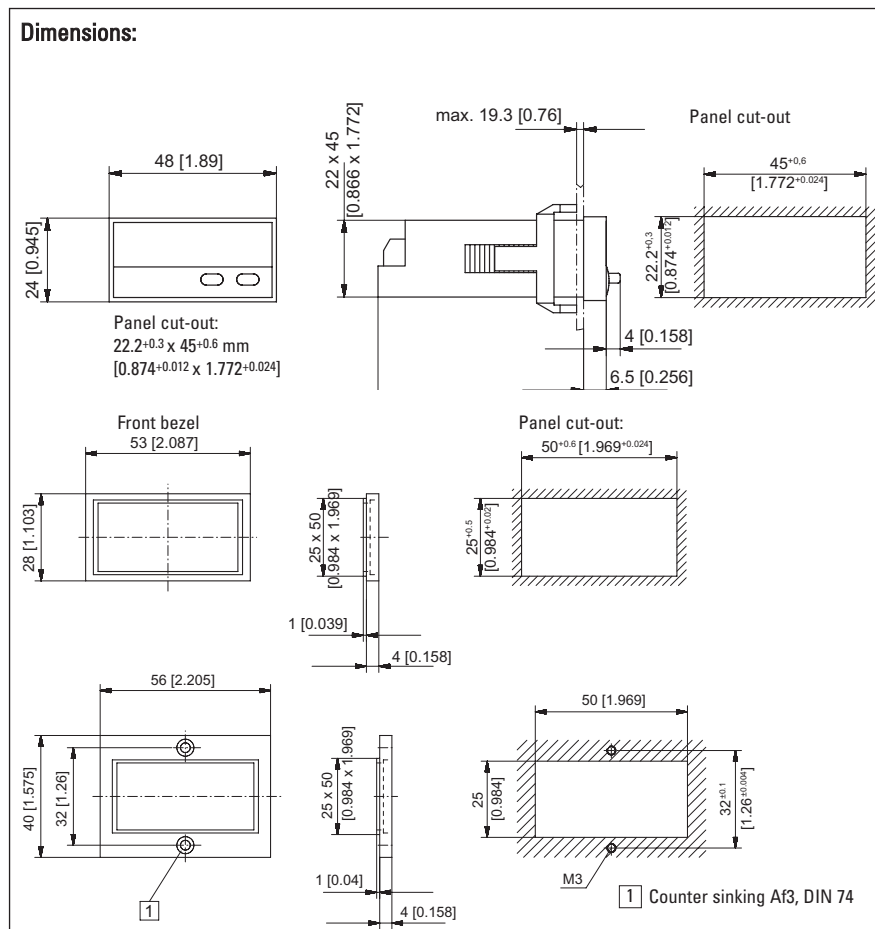

### Connections:

without optocoupler

- 1 10 ... 30 V DC
- 2 0 V GND
- 3 INP A
- 4 INP B
- 5 Reset

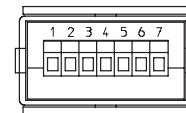
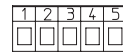

### Delivery specifications:

- 1 Digital display
- 1 Panel mounting clip
- 1 Bezel for screw mounting, panel cut out 50 x 25 mm [ 1.969 x 0.984"]
- 1 Bezel for clip mounting, panel cut out 50 x 25 mm [1.969 x 0.984"]
- 1 Seal
- 1 Multilingual operating instructions

### Order code:

6.52U.012.3X0

Input switch level  
0 = Standard\*  
A = 5 V

\* standard stock model

## Position and Frequency display **CODIX 52P**

separate inputs for frequency and position

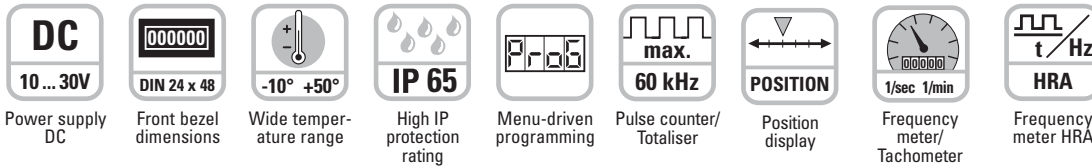

### Powerful

- **Fast count input**  
Input frequency max. 60 kHz
- **Robust housing**  
IP 65 protection
- **LED display**  
Very bright, 8 mm high
- **HRA – High Rate Accuracy System**  
Frequencies up to 38 Hz are calculated using time-interval (period duration) measurement.  
Frequencies > 38 Hz are calculated using a special time base (gate time) measurement. A very high accuracy of > 0.1% is achieved, even with very short gate times. The resulting measurement is available after a max. of 50 ms.
- **Fast start-up time**  
Detects incoming pulses just 16 ms after being switched on – so no pulses are lost with a simultaneous motor start-up



### User-friendly

- **Big keys**  
Can also be operated when using gloves
- **Easy to programme**  
Easy menu-driven programming and operation  
Possibility to enter the programming mode during operation, with authentication query  
Pressing the right key switches between displays

### Universal

- **Individually programmable scaling**  
Multiplication and division factor (0.0001 to 99.9999), to display corresponding engineering units, e.g. position in 1/10 mm and speed in RPM.
- **Separate factors and inputs for frequency- and pulse counting**
- **4 different count input modes for the position display**  
2-channel input for detecting count direction, difference or adding mode, quadrature x1, x2 or x4. 1 separate input for rotary speed and speed, display in 1/min or 1/sec
- **DC supply**
- **Inputs**  
As an alternative to the HTL inputs, devices with a 5 VDC input trigger level are available, for use as parallel displays for PLCs.

### Applications for Frequency and Position Display/ Totaliser

Position and rotary speed applications, e.g.

- OEM equipment or retrofitting to drilling machines
- OEM equipment on flow measuring plant, e.g. total flow and current flow

- Total piece count and pieces per minute, where the pulse counting occurs in the add/subtract mode, in order to deduct reject parts

- Production data acquisition: total piece count and production speed, or absolute distance traversed and current speed

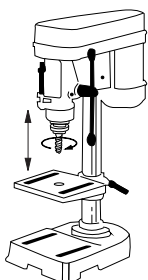

Rotary speed and drilling depth

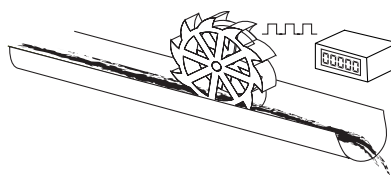

Flow rate and total volume

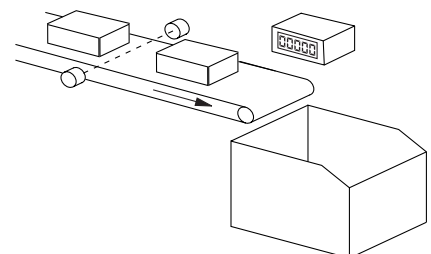

Piece count on conveyor and production speed



## Position and Frequency display **CODIX 52P**

### Technical data:

Supply voltage:	10 ... 30 V DC, with reverse polarity protection	Level of inputs:	Low: 0 ... 0.2 x U <sub>B</sub> [V DC] High: 0.6 x U <sub>B</sub> ... 30 V DC
Current consumption:	max. 40 mA	Level of inputs:	Low: 0 ... 2 V DC High: 4 ... 30 V DC
Display:	6 digit red 7-segment LED; 8 mm [0.315"] high	5 V version	High: 4 ... 30 V DC
Data backup:	EEPROM	Accuracy:	<0.1 % (Frequency display, tachometer)
Housing:	dimension 48 x 24 mm [1.89 x 0.945"] according to DIN 43 700; RAL 7021, grey	EMC:	according to EC EMC directive 89/36/EWG
Polarity of inputs:	programmable, npn or pnp for all inputs	Immunity to interference:	EN 61000-6-4/EN 55011 class B
Input resistance:	approx. 5 kΩ	Emitted interference:	EN 61000-6-2
Counting frequency:	30 kHz, can be damped to 30 Hz	Ambient temperature:	-10 ... +50 °C [14 ... 122 °F]
Reset time:	5 ms	Storage temperature:	-25 ... +70 °C [-13 ... 158 °F]
		Protection:	IP 65 front side
		Weight:	approx. 50 g [1.764 oz]

### Block diagram:

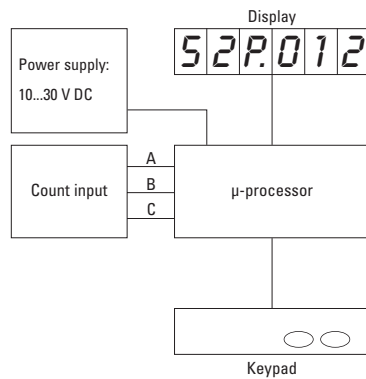

### Dimensions:

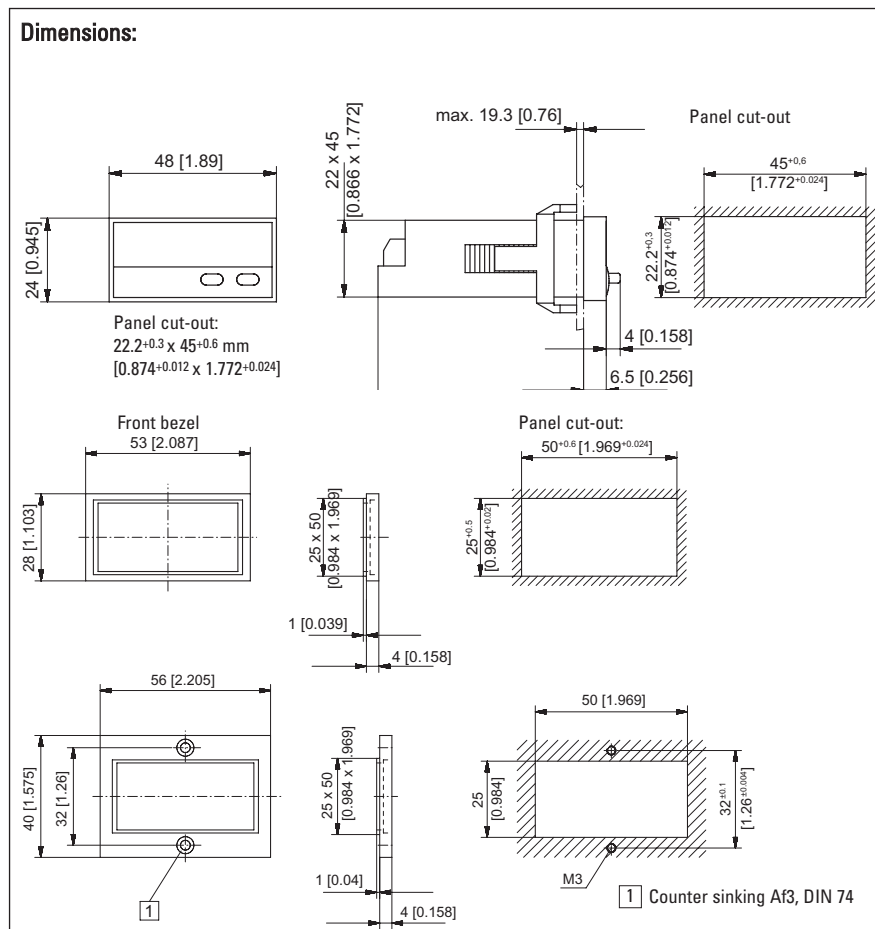

### Connections:

without optocoupler

- 1 10 ... 30 V DC
- 2 0 V GND
- 3 INP A
- 4 INP B
- 5 Reset

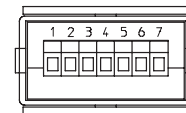
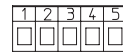

### Delivery specifications:

- 1 Digital display
- 1 Panel mounting clip
- 1 Bezel for screw mounting, panel cut out  
50 x 25 mm [ 1.969 x 0.984"]
- 1 Bezel for clip mounting, panel cut out  
50 x 25 mm [1.969 x 0.984"]
- 1 Seal
- 1 Multilingual operating instructions

### Order code:

6.52P.012.3X0

Input switch level

0 = Standard\*

A = 5 V

\* standard stock model

## Totaliser *CODIX 540*

- Simple programmable pulse counter Codix 520
- Single channel totaliser

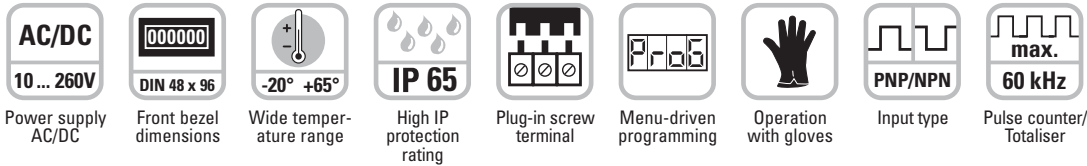

### Powerful

- **Fast count input**  
Input frequency max. 60 kHz
- **Robust housing**  
IP 65 protection
- **LED display**  
Very bright, 14 mm high
- **Simple totalizing and quantity counters**  
Single channel count input and reset input  
Programmable for positive (PNP) or negative (NPN) switching input pulses  
Fast count input with an input frequency of max. 60 kHz, can be damped to 30 Hz for mechanical contacts
- **Fast start-up time**  
Detects incoming pulses just 16 ms after being switched on – so no pulses are lost with a simultaneous motor start-up



### User-friendly

- **Big keys**  
Can also be operated when using gloves
- **Easy to programme**  
Easy menu-driven programming and operation  
Possibility to enter the programming mode during operation, with authentication query

### Universal

- **Programmable decimal point**  
Can be set between 0.0 and 0.000
- **Manual or electrical reset**  
Tamper-proof, due to lockable reset function
- **AC or DC power supply**  
With sensor power supply
- **Inputs**  
As an alternative to the HTL inputs, devices with a 5 VDC input trigger level are available, for use as parallel displays for PLCs

## Applications for Pulse Counters/ Totalisers

- Simple count tasks such as quantity and piece counting
- Accessories, OEM equipment or retrofitting to production machines
- Piece counting on die cutters, presses, extruders, woodworking machines, drilling machines, pick-and-place machines, guillotines, special-purpose vehicles etc.

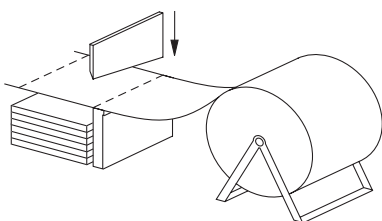

Piece-counting

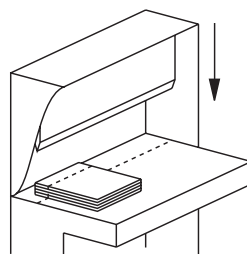

Number of cuts

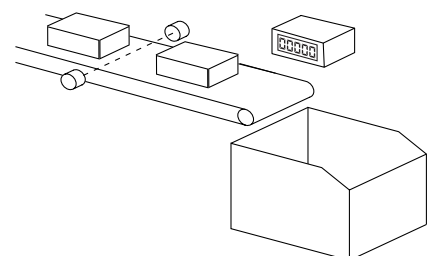

Piece-counting on conveyor

## Totaliser **CODIX 540**

### Technical data:

Supply voltage( $U_B$ ):	10 ... 30 V DC, with reverse polarity protection 90 ... 260 V AC
Current consumption:	max. 50 mA, 6 VA
Display:	6-digit red 7-segment LED display; 14 mm [0.551"] high
Data backup:	EEPROM
Housing:	dimension 48 x 24 mm [1.89 x 0.945"] according to DIN 43 700; RAL 7021, grey
Polarity of Inputs:	programmable, npn or pnp for all inputs
Input resistance:	approx. 5k $\Omega$
Counting frequency*:	max. 60 kHz, can be damped to 30 Hz, depending on operating mode
Reset time:	5 ms
Input switching level (standard version):	DC-version: Low: 0 ... 0.2 [0 ... 0.008"] x $U_B$ [V DC] High: 0.6 [0.024"] x $U_B$ ... 30 V DC

	AC-version
	Low 0 ... 4 V DC
	High 12 ... 30 V DC
Input switching level (5 V version):	Low 0 ... 2 V DC High 4 ... 30 V DC
Voltage output for sensors:	24 V DC $\pm$ 15 %/100 mA for AC-version
Ambient temperature:	-20 ... +65 °C [-4 °F ... 149 °F] non-condensing
Storage temperature:	-25 ... +70 °C [-13 °F ... 158 °F]
EMC:	according to EC EMC directive 89/36/EWG
Immunity to interference:	EN 61000-6-4/EN 55011 class B
Emitted interference:	EN 61000-6-2
Protection:	IP 65 front side
Weight:	approx. 150 g [5.291 oz]

\*for further specifications please refer to the manual

### Block diagram:

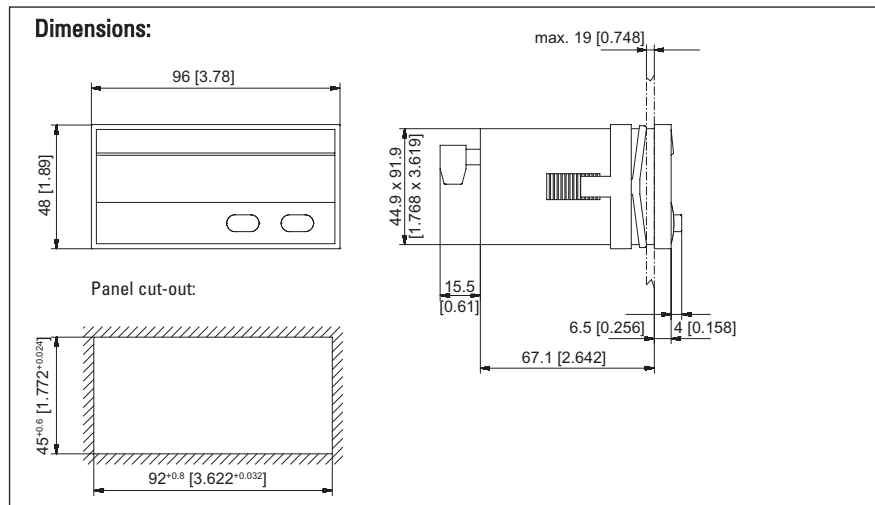
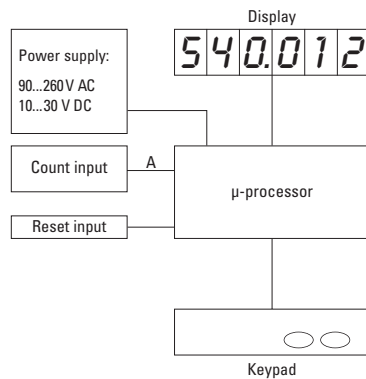

### Order code:

**6.540.012.XX0**

Input switching level  
0 = Standard level\*  
A = 5 V level

Voltage supply  
0 = 90 ... 260 V AC\*  
3 = 10 ... 30 V DC\*

\*standard stock model

### Connections:

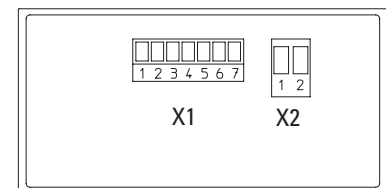

#### Connection: X2

Pin	AC-version	DC-version
1	90 ... 260 V AC	0 V DC (GND)
2	90 ... 260 V AC	10 ... 30 V DC

#### Connection X1

Pin	AC-version	DC-version
1	n.c.	
2	n.c.	
3	Reset	
4	n.c.	
5	INP	
6	GND out	n.c.
7	+24 Vout	n.c.

**Delivery specification:** Multilingual operating instructions  
Digital display  
Mounting clip  
Seal

## Position indicator or totaliser **CODIX 541**

### 4 count modes:

- Count with direction
- Count difference
- Count sum of 2 inputs
- Phase discriminator (quadrature) x1, x2 and x4

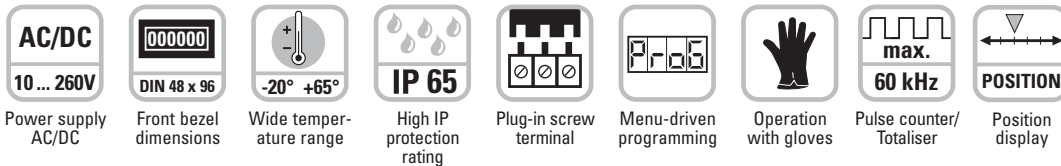

### Powerful

- **Fast count input**  
Input frequency max. 60 kHz
- **Robust housing**  
IP 65 protection
- **LED display**  
Very bright, 14 mm high
- **Position, difference, adding or detection of count direction**  
Programmable for positive (PNP) or negative (NPN) switching input pulses  
Fast count input with an input frequency of max. 60 kHz, can be damped to 30 Hz for mechanical contacts
- **Fast start-up time**  
Detects incoming pulses just 16 ms after being switched on – so no pulses are lost with a simultaneous motor start-up



### User-friendly

- **Big keys**  
Can also be operated when using gloves
- **Easy to programme**  
Easy menu-driven programming and operation  
Possibility to enter the programming mode during operation, with authentication query

### Universal

- **Individually programmable scaling**  
Multiplication and division factor (0.0001 to 99.9999), to display corresponding engineering units, e.g. position in 1/10 mm and speed in RPM.
- **4 different count input modes**  
2-channel input for detecting count direction, difference or adding mode, quadrature x1, x2 or x4
- **Programmable setpoint**
- **AC or DC power supply**  
With sensor power supply
- **Inputs**  
As an alternative to the HTL inputs, devices with a 5 VDC input trigger level are available, for use as parallel displays for PLCs.
- **Optional output**  
As zero signal

## Applications for Position Displays and Totalisers

- Positioning tasks on processing machines, such as sawing machines, milling machines, bending and folding machines, etc.
- Production data acquisition by means of piece counting (using difference or adding)
- Totalizing flow, quantity and other scaleable media
- Counting tasks such as quantity and piece counting
- Accessories, OEM equipment or retrofitting to production machines
- Piece counting on die cutters, presses, extruders, woodworking machines, drilling machines, pick-and-place machines, guillotines, special-purpose vehicles etc.

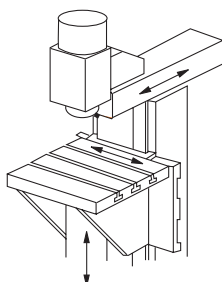

Position on milling machine

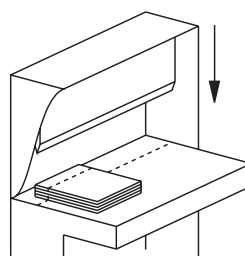

Position or quantity

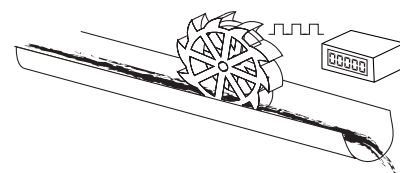

Flow rate

## Position indicator or totaliser **CODIX 541**

### Technical data:

Supply voltage:	10 ... 30 V DC, with reverse polarity protection 90 ... 260 V AC
Current consumption:	max. 50 mA, 6 VA
Display:	6-digit 7-segment red LED display; 14 mm [0.551"] high
Data backup:	EEPROM
Housing:	dimension 96 x 48 mm [3.78 x 1.89"] according to DIN 43 700; RAL 7021, grey
Polarity of Inputs:	programmable, npn or pnp for all inputs
Input resistance:	approx. 5 k $\Omega$
Counting frequency*:	max. 60 kHz, can be damped to 30 Hz, depending on operating mode at position display max. 25 kHz
Reset time:	5 ms
Input switching level (standard version):	DC-version Low: 0 ... 0.2 x U <sub>B</sub> [V DC] High: 0.6 x U <sub>B</sub> ... 30 V DC

### AC-version

	Low 0 ... 4 V DC
	High 12 ... 30 V DC
Input switching level (5 V version):	Low 0 ... 2 V DC High 4 ... 30 V DC
Voltage supply for sensors:	24 V DC $\pm$ 15 %/100 mA for AC version
Max power consumption	max. 30 V, 10 mA
Optocouplers:	
Ambient temperature:	-20 ... +65 °C [-4 ... 149 °F] non-condensing
Storage temperature:	-25 ... +70 °C [-13 ... 158 °F]
EMC:	according to EC EMC directive 89/36/EWG
Emitted interference:	EN 61000-6-4/EN 55011 class B
Immunity to interference:	EN 61000-6-2
Protection:	IP 65 front side
Weight:	approx. 150 g [5.291 oz]

\*for further specifications please refer to the manual

### Block diagram:

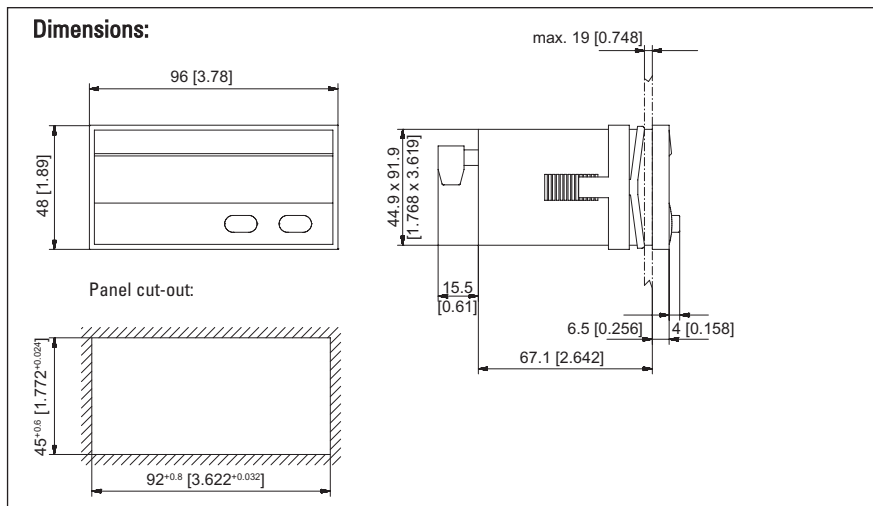
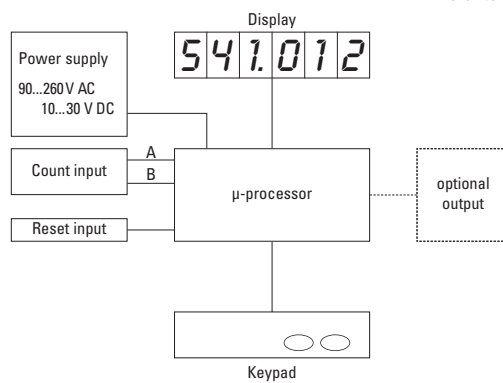

### Order code:

**6.541.01X.XX0**

Output 1 = Optocoupler output 2 = No output	Input switching level 0 = Standard level* A = 5 V level	Voltage supply 0 = 90 ... 260 V AC* 3 = 10 ... 30 V DC*
---	---	---

\* standard stock model

### Connections:

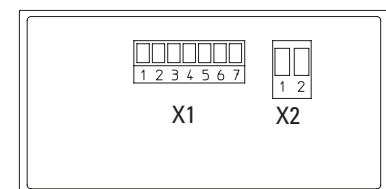

### Connection X2:

Pin	AC-version	DC-version
1	90 ... 260 V AC	0 V DC (GND)
2	90 ... 260 V AC	10 ... 30 V DC

### Connection X1:

Pin	AC-version	DC-version
1	Optocoupler-output Emitter	
2	Optocoupler-output Collector	
3	Set	
4	INP B	
5	INP A	
6	GNDout	n.c.
7	+24 Vout	n.c.

**Delivery specification:** Seal  
Digital display Multilingual operating instructions  
Mounting clip

## Multifunction display *CODIX 544*

programmable as:

- Pulse counter
- Position display
- Frequency / speed display
- Timer/ short time meter



Power supply  
AC/DC



Front bezel  
dimensions

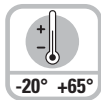

Wide temper-  
ature range



High IP  
protection  
rating



Plug-in screw  
terminal



Menu-driven  
programming

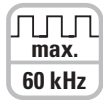

Pulse counter/  
Totaliser

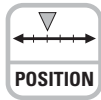

Position  
display



Frequency  
meter/  
Tachometer



Timer/  
Hour Meter



Frequency  
meter HRA

### Powerful

- **Fast count input**  
Input frequency max. 60 kHz
- **Robust housing**  
IP 65 protection
- **LED display**  
Very bright, 14 mm high
- **HRA – High Rate Accuracy System**  
Frequencies up to 38 Hz are calculated using time-interval (period duration) measurement.  
Frequencies > 38 Hz are calculated using a special time base (gate time) measurement. A very high accuracy of > 0.1% is achieved, even with very short gate times. The resulting measurement is available after a max. of 50 ms.
- **Fast start-up time**  
Detects incoming pulses just 16 ms after being switched on – so no pulses are lost with a simultaneous motor start-up



### User-friendly

- **Big keys**  
Can also be operated when using gloves
- **Easy to programme**  
Easy menu-driven programming and operation  
Possibility to enter the programming mode during operation, with authentication query

### Universal

- **Individually programmable scaling**  
Multiplication and division factor (0.0001 to 99.9999), to display corresponding engineering units, e.g. position in 1/10 mm and speed in RPM
- **4 different count input modes**  
2-channel input for detecting count direction, difference or adding mode, quadrature x1, x2 or x4
- **Frequency measurement**  
Display in 1/min or 1/sec
- **Time counting**  
Pulse width or time interval measurement in hours, minutes or seconds, as well as real-time display
- **AC or DC power supply**  
With sensor power supply
- **Inputs**  
As an alternative to the HTL inputs, devices with a 5 VDC input trigger level are available, for use as parallel displays for PLCs.
- **Optional output**  
Zero signal for position and count, zero-speed monitoring, 1 Hz clock pulse for active time measurement

### Applications for Multi-function Display

- Counting tasks such as quantity and piece counting, measuring and recording of speed and of operating and processing times
- Piece counting or tool-life measurement on die cutters, presses, extruders, wood-working machines, drilling machines,

- pick-and-place machines, guillotines, special-purpose vehicles etc.
- Positioning tasks on processing machines, such as sawing machines, milling machines, bending and folding machines, etc.

- Production data acquisition by means of piece counting (using difference or adding), or measurement of production times or production speeds.
- Totalizing flow, quantity and other scaleable media, or display of current flow rates.

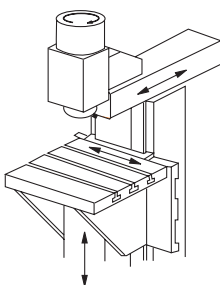

Position or rotary speed on milling machine

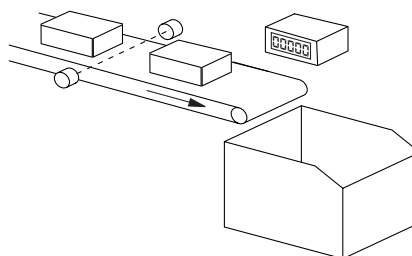

Piece count on conveyor or production speed

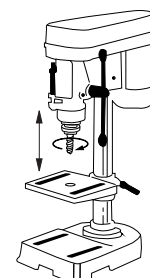

Drilling machine head, speed or drilling depth

## Multifunction display **CODIX 544**

### Technical data:

Supply voltage:	10 ... 30 V DC, with reverse polarity protection 90 ... 260 V AC
Current consumption:	max. 50 mA, 6 VA
Display:	6-digit 7-segment red LED display; 14 mm high [0.551"]
Data backup:	EEPROM
Housing:	dimension 96 x 48 mm [3.78 x 1.89"] according to DIN 43 700; RAL 7021, grey
Polarity of Inputs:	programmable, npn or pnp for all inputs
Input resistance:	approx. 5 kΩ
Counting frequency*:	60 kHz, can be damped to 30 Hz depending on operating mode at position display max. 25 kHz
Reset time:	5 ms
Display range timer:	0.001 s ... 999999 h
Input switching level (standard version):	DC-version Low: 0 ... 0.2 [0 ... 0.008"] x U <sub>B</sub> [V DC] High: 0.6 x [0.024"] U <sub>B</sub> ... 30 V DC

	AC-version
	Low 0 ... 4 V DC
	High 12 ... 30 V DC
Input switching level (5 V version):	Low: 0 ... 2 V DC High: 4 ... 30 V DC
Voltage supply for sensors:	24 V DC ±15 %/100 mA at AC-versions
Accuracy:	Tachometer: <0,1 % Timer < 50 ppm
Ambient temperature:	-20 ... +65 °C [-4 ... 149 °F]
Storage temperature:	-25 ... +70 °C [-13 ... 158 °F]
EMC:	according to EC EMC directive 89/36/EWG
Emitted interference:	EN 61000-6-4/EN 55011 class B
Immunity to interference:	EN 61000-6-2
Protection:	IP65 from front
Weight:	approx. 150 g [5.291 oz]

\*for further specifications please refer to the manual

### Block diagram:

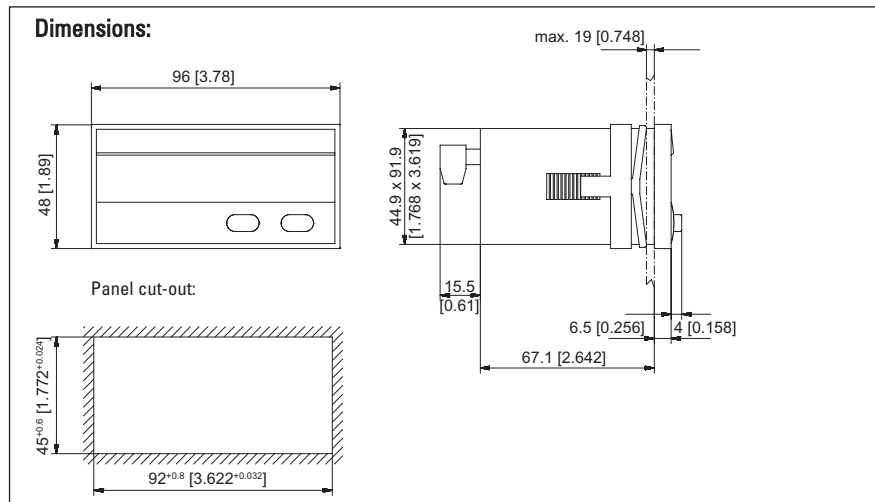
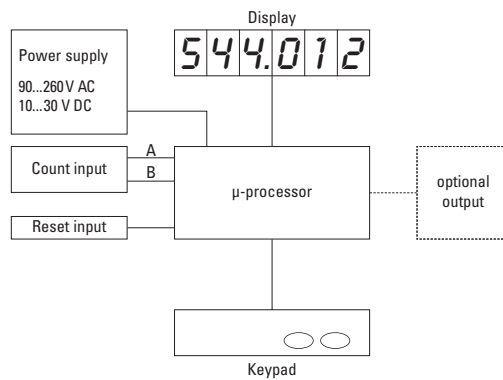

### Order code:

**6.544.01X.XX0**

Output  
1 = Optocoupler output\*  
2 = No output

Input switching level  
0 = Standard level\*  
A = 5 V level

Voltage supply  
0 = 90 ... 260 V AC\*  
3 = 10 ... 30 V DC

\* standard stock model

### Connections:

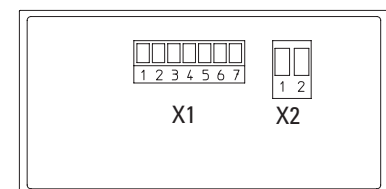

#### Connection: X2:

Pin	AC-version	DC-version
1	90 ... 260 V AC	0 V DC (GND)
2	90 ... 260 V AC	10 ... 30 V DC

#### Connection X1:

Pin	AC-version	DC-version
1	Optocoupler-output Emitter	
2	Optocoupler-output Collector	
3	Set	
4	INP B	
5	INP A	
6	GNDout	n.c.
7	+24 Vout	n.c.

**Delivery specification:** Seal  
Digital display Multilingual operating instructions  
Mounting clip

## Universal with dual functions **CODIX 54U**

**4 dual functions in one device**  
 > solves all applications where 2 different values must be displayed simultaneously.

- Counter with 2 totalizing ranges
- Totaliser and time counter
- Totaliser and frequency counter
- Timer with 2 time ranges

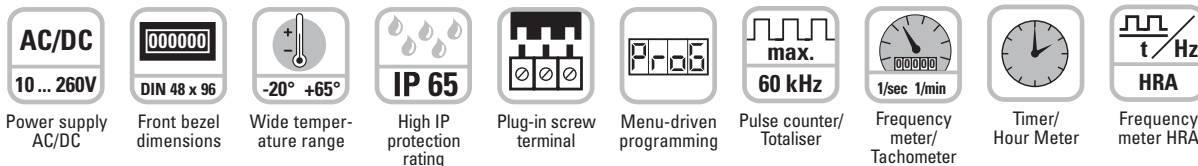

### Powerful

- **Fast count input**  
Input frequency max. 60 kHz
- **Robust housing**  
IP 65 protection
- **LED display**  
Very bright, 14 mm high
- **HRA – High Rate Accuracy System**  
Frequencies up to 38 Hz are calculated using time-interval (period duration) measurement.  
Frequencies > 38 Hz are calculated using a special time base (gate time) measurement. A very high accuracy of > 0.1% is achieved, even with very short gate times. The resulting measurement is available after a max. of 50 ms.
- **Fast start-up time**  
Detects incoming pulses just 16 ms after being switched on – so no pulses are lost with a simultaneous motor start-up



### User-friendly

- **Big keys**  
Can also be operated when using gloves
- **Easy to programme**  
Easy menu-driven programming and operation  
Possibility to enter the programming mode during operation, with authentication query  
Pressing the right key switches between displays

### Universal

- **Individually programmable scaling**  
Multiplication and division factor (0.0001 to 99.9999), to display corresponding engineering units, e.g. position in 1/10 mm and speed in RPM
- **Separate factors for frequency- and pulse counting**
- **AC or DC power supply**  
With sensor power supply
- **Inputs**  
As an alternative to the HTL inputs, devices with a 5 VDC input trigger level are available, for use as parallel displays for PLCs
- **Timer specials**  
Timer or hours-run meter with various Start Stop measurements, time range settings in hours, minutes or seconds, with decimal point. Resolutions up to 1/1000 can be programmed

### Applications for dual functions

- **Pulse and frequency (speed)**  
e.g. production data acquisition: total piece count and speed on OEM equipment, flow rate measuring systems – total flow and current flow
- **2 pulse counters**  
Measurement of batch and total piece count, or of daily production count and total count values

- **Pulse and time (Maintenance counter)**  
Used in the lift industry as trip counters and hours-run meters and on production machines for piece and time counting, flow and time measurement, materials handling time and quantities

- **2 timers**  
Measurement of total time and order-specific times, maintenance intervals and total time, time of day and total time.

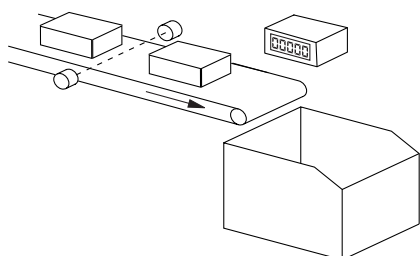

Piece count on conveyor and production speed

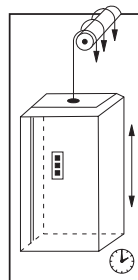

Trip counter and hours-run

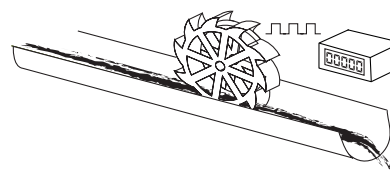

Flow rate and total volume



## Universal with dual functions **CODIX 54U**

### Technical data:

Supply voltage:	10 ... 30 V DC, with reverse polarity protection 90 ... 260 V AC
Current consumption:	max. 50 mA, 6 VA
Display:	6-digit 7-segment red LED display; 14 mm [0.551"] high
Data backup:	EEPROM
Housing:	Dimension 96 x 48 mm [3.78 x 1.89"] according to DIN 43 700; RAL 7021, grey
Polarity of Inputs:	programmable, npn or pnp for all inputs
Input resistance:	approx. 5 k $\Omega$
Counting frequency*:	60 kHz, can be damped to 30 Hz depending on operating mode
Display range:	0.001 s ... 999999 h
Reset time:	5 ms
Input switching level (standard version):	DC-version: Low: 0 ... 0.2 [0 ... 0.008"] x U <sub>B</sub> [V DC] High: 0.6 [0.024"] x U <sub>B</sub> ... 30 V DC

AC-version:	Low 0 ... 4 V DC High 12 ... 30 V DC
Input switching level (5 V version):	Low 0 ... 2 V DC High 4 ... 30 V DC
Voltage supply for sensors:	24 V DC $\pm$ 15 %/100 mA at AC version
Accuracy:	<0.1 % (Frequency display/Rate meter) <50 ppm (Timer)
Ambient temperature:	-20 ... +65 °C [-4 ... 149 °F] non-condensing
Storage temperature:	-25 ... +70 °C [-13 ... 158 °F]
EMC:	according to EC EMC directive 89/36/EWG
Emitted interference:	EN 61 000-6-4/EN 55 011 class B
Immunity to interference:	EN 61 000-6-2
Protection:	IP65 from front
Weight:	approx. 150 g [5.291 oz]

\*for further specifications please refer to the manual

### Block diagram:

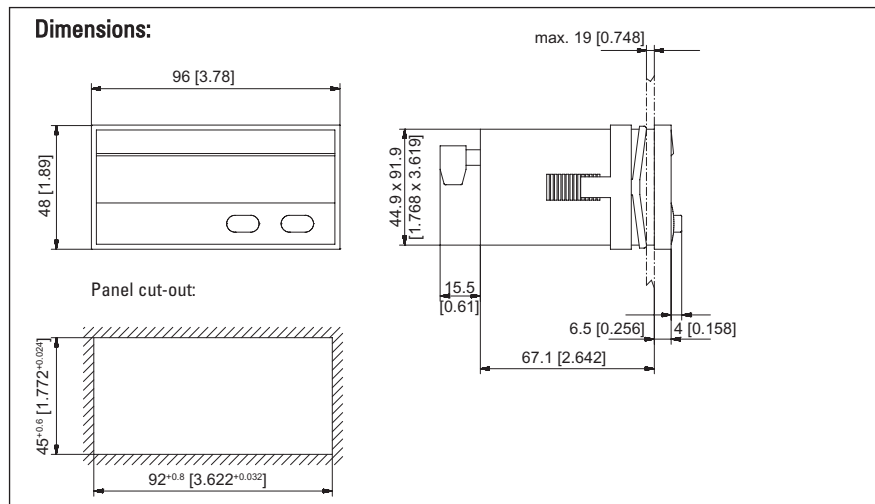
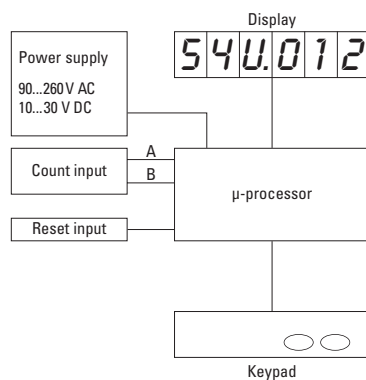

### Order code:

6.54U.012.XX0

Input switching level  
0 = Standard\*  
A = 5 V level

Power supply  
0 = 90 ... 260 V AC\*  
3 = 10 ... 30 V DC  
\* standard stock model

### Connections:

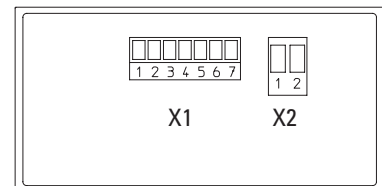

#### Connection: X2

Pin	AC-version	DC-version
1	90 ... 260 V AC	0 V DC (GND)
2	90 ... 260 V AC	10 ... 30 V DC

#### Connection: X1

Pin	AC-Version	DC-Version
1	n.c.	
2	n.c.	
3	Reset	
4	INP B	
5	INP A	
6	GNDout	n.c.
7	+24 Vout	n.c.

**Delivery specification:**  
Digital display  
Mounting clip

Seal  
Multilingual operating instructions

## Position and Frequency display **CODIX 54P**

separate inputs for frequency and position

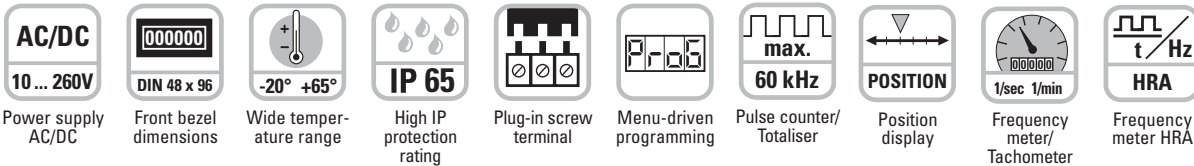

### Powerful

- **Fast count input**  
Input frequency max. 60 kHz
- **Robust housing**  
IP 65 protection
- **LED display**  
Very bright, 14 mm high
- **HRA – High Rate Accuracy System**  
Frequencies up to 38 Hz are calculated using time-interval (period duration) measurement.  
Frequencies > 38 Hz are calculated using a special time base (gate time) measurement. A very high accuracy of > 0.1% is achieved, even with very short gate times. The resulting measurement is available after a max. of 50 ms.
- **Fast start-up time**  
Detects incoming pulses just 16 ms after being switched on – so no pulses are lost with a simultaneous motor start-up



### User-friendly

- **Big keys**  
Can also be operated when using gloves
- **Easy to programme**  
Easy menu-driven programming and operation  
Possibility to enter the programming mode during operation, with authentication query  
Pressing the right key switches between displays

### Universal

- **Individually programmable scaling**  
Multiplication and division factor (0.0001 to 99.9999), to display corresponding engineering units, e.g. position in 1/10 mm and speed in RPM.
- **Separate factors and inputs for frequency- and pulse counting**
- **4 different count input modes for the position display**  
2-channel input for detecting count direction, difference or adding mode, quadrature x1, x2 or x4. 1 separate input for rotary speed and speed, display in 1/min or 1/sec
- **AC or DC power supply**  
With sensor power supply
- **Inputs**  
As an alternative to the HTL inputs, devices with a 5 VDC input trigger level are available, for use as parallel displays for PLCs

## Applications for Frequency and Position Display/ Totaliser

Position and rotary speed applications, e.g.

- OEM equipment or retrofitting to drilling machines
- OEM equipment on flow measuring plant, e.g. total flow and current flow
- Total piece count and pieces per minute, where the pulse counting occurs in the add/subtract mode, in order to deduct reject parts
- Production data acquisition: total piece count and production speed, or absolute distance traversed and current speed

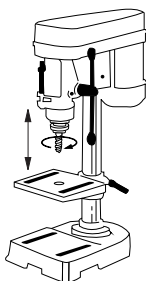

Rotary speed and drilling depth

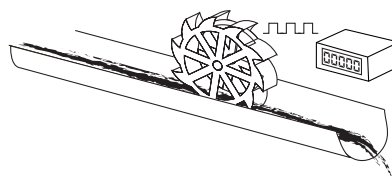

Flow rate and total volume

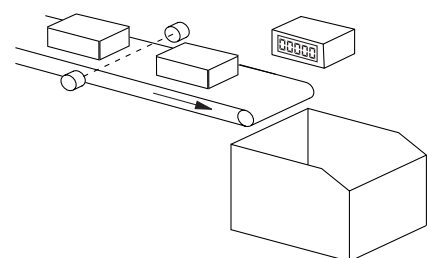

Piece count on conveyor and production speed

## Position and Frequency display **CODIX 54P**

### Technical data:

Supply voltage:	10 ... 30 V DC, with reverse polarity protection 90 ... 260 V AC
Current consumption:	max. 50 mA, 6 VA
Display:	6-digit 7-segment red LED display; 14 mm [0.551"] high
Data backup:	EEPROM
Housing:	Dimension 96 x 48 mm [3.78 x 1.89"] according to DIN 43 700; RAL 7021, grey
Polarity of Inputs:	programmable, npn or pnp for all inputs
Input resistance:	approx. 5 kΩ
Counting frequency*:	30 kHz, can be damped to 30 Hz depending on operating mode
Reset time:	5 ms
Input switching level (standard version):	DC-version: Low: 0 ... 0.2 [0 ... 0.008"] x U <sub>B</sub> [V DC] High: 0.6 [0.024"] x U <sub>B</sub> ... 30 V DC

AC-version:	Low 0 ... 4 V DC High 12 ... 30 V DC
Input switching level (5 V version):	Low 0 ... 2 V DC High 4 ... 30 V DC
Accuracy:	<0.1 % (Frequency display/Rate meter)
Voltage supply for sensors:	24 V DC ±15 %/100 mA at AC version
Ambient temperature:	-20 ... +65 °C [-4 ... 149 °F] non-condensing
Storage temperature:	-25 ... +70 °C [-13 ... 158 °F]
EMC:	according to EC EMC directive 89/36/EWG
Emitted interference:	EN 61000-6-4/EN 55011 class B
Immunity to interference:	EN 61000-6-2
Protection:	IP65 from front
Weight:	approx. 150 g [5.291 oz]

\*for further specifications please refer to the manual

### Block diagram:

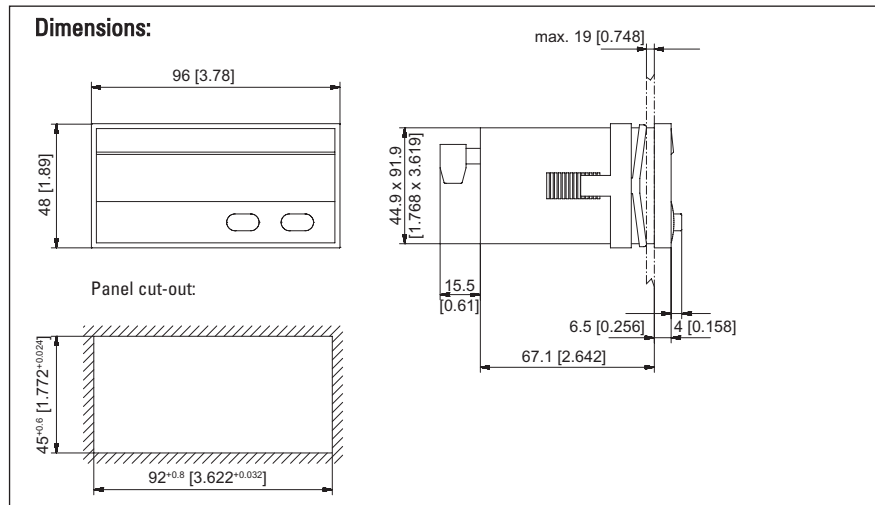
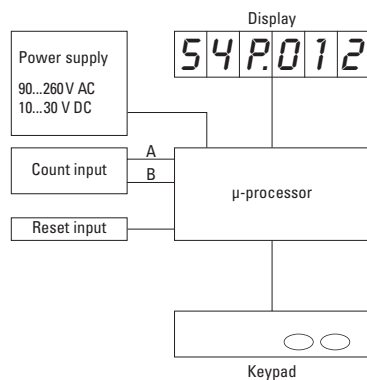

### Order code:

**6.54P.012.XX0**

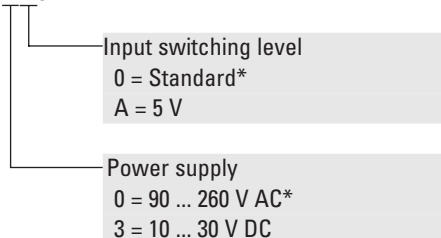

\* standard stock model

### Connections:

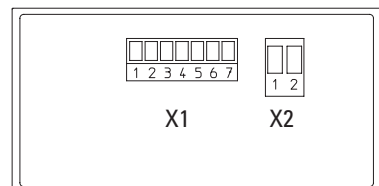

#### Connection: X2

Pin	AC-version	DC-version
1	90 ... 260 V AC	0 V DC (GND)
2	90 ... 260 V AC	10 ... 30 V DC

#### Connection: X1

Pin	AC-Version	DC-Version
1	n.c.	
2	n.c.	
3	INP C (Frequency)	
4	INP B (Count)	
5	INP A (Count)	
6	GNDout	n.c.
7	+24 Vout	n.c.

### Delivery specification:

- Digital display
- Mounting clip
- Seal
- Multilingual operating instructions

## LCD Counter Module 190



- Counting frequency up to 10 kHz
- 7-digit display, height 6 mm [0.236"]
- Non-volatile memory (no battery, EEPROM)
- High reliability
- Low operating current
- Wide operating voltage and temperature range
- Very high shock and vibration specs
- Low cost and small size

### Technical features for LCD Counter Module Type 190:

Supply:	1. 4.75 ... 15 V DC 2. 9 ... 60 V DC reverse polarity protection
Current consumption:	1. 8 mA at 4.75 ... 15 V DC 2. 6 mA at 9 ... 60 V DC
Count and reset input:	High 4 ... 60 V DC, Low: 0 ... 0,7 V DC
Max. count frequency:	10 kHz (edge triggered)
Display:	7-digit display, figure height 6 mm [0.236"]
Data backup:	EEPROM
Colour:	black
Working temperature:	-20 ... +85 °C [-4 ... 185 °F]
Operating temperature:	-40 ... +80 °C [-40 ... 176 °F]
Storage temperature:	-50 ... +90 °C [-58 ... 194 °F]

Emitted interference:	EN 61 000-6-3, EN 55 011 Class B
Immunity to interference:	EN 61 000-6-2
Weight:	approx. 8 g [0.282 oz]
Memory capacity:	CMOS EEPROM. non-volatile memory has data retention in excess of 10 years.
Shock resistance acc. to DIN-IEC 68-2-27:	550 m/s <sup>2</sup> , 11 ms
Vibration resistance acc. to DIN-IEC 68-2-6:	50 ... 200 m/s <sup>2</sup> , 10 ... 80 Hz
Needs protection from:	inductive stress peaks, high energy noise, fields switching, alternator load dump

### Dimensions:

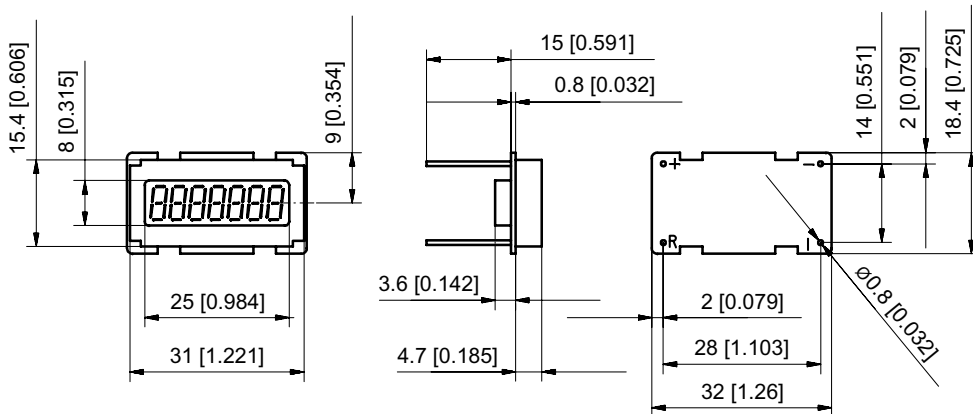

### Connecting diagram:

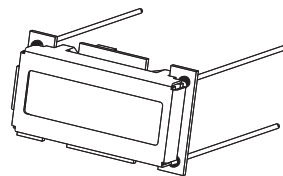
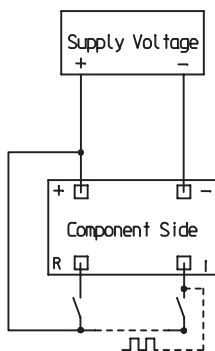

### Order code:

LCD count module type 190:  
 4.75 ... 15 V DC Order-No.: 6.190.012.F00  
 Art-No.: 162 135  
 9 ... 60 V DC Order-No.: 6.190.012.G00  
 Art-No.: 162 136

### Delivery specifications:

- LCD Counter Module Type 190
- Operating instructions

## LCD Counter Module 192



- Non-volatile memory (no battery)
- High reliability
- Low cost and small size
- Low operating current
- Wide operating voltage and temperature range
- Very high shock and vibration specs
- Solid state electronics



### Technical features for LCD Counter Module Type 192:

Supply:	4.5 ... 28 V DC	Humidity:	95 % RH +32 C for 2 hours
Current consumption:	3 mA maximum at 8 ... 24 V DC 10 mA at 28 V DC	EMC:	according to EC EMC directive 89/36/EWG
Count and reset input:	8 ... 28 V DC	Emitted interference:	EN 61000-6-3/EN 55011 Class B
Max. Count frequency:	100 Hz	Immunity to interference:	EN 61000-6-2
Display:	6-digit display, figure height 5 mm [0.197"]	Weight:	approx. 8 g [0.282 oz]
Data backup:	EEPROM	Memory capacity:	CMOS EEPROM. non-volatile memory has data retention in excess of 10 years without power.
Housing:	Dimensions 19 x 33 mm [0.748 x 1.299"]	Needs protection from:	inductive stress peaks, high energy noise, fields switching, alternator load dump
Colour:	black		
Operating temperature:	-40 ... +85 °C [-40 ... 185 °F]		

### Dimensions:

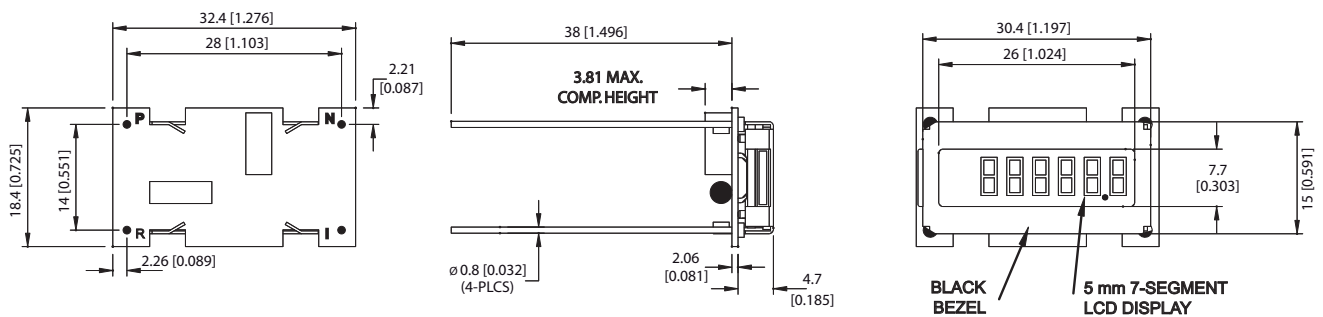

### Connecting diagram:

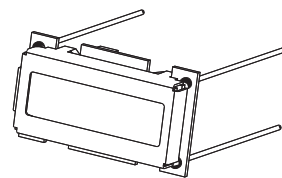
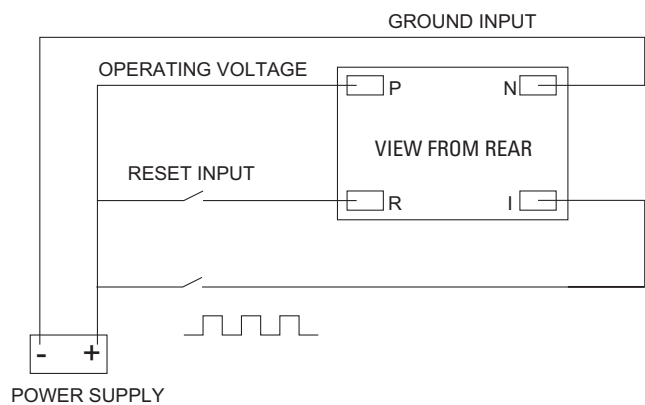

**Order code:**  
LCD Counter Module Type 192:  
Order-No.: 6.192.012.300\*

**Delivery specifications:**  
– LCD Counter Module Type 192  
– Operating instructions

\* standard stock model

## 4 digit LCD module 166



- 4-digit LCD totaliser for panel mounting
- Removable housing for special applications
- Power supply from replaceable lithium battery, 3 ... 4 years at 20 °C [68 °F]
- Max. count frequency 18 Hz by contact

**Applications:**  
 devices without power supply  
 easy counting  
 self powered device  
 vending machines  
 gaming machines  
 printers and copiers

### Technical data:

Power supply:	1.5 V lithium battery Type 386 or SR 43	Interference emission:	EN 50081-2/EN 55011 class B
Battery operating life:	3 ... 4 Years at 20 °C [68 °F]	Interference resistance:	EN 6100-6-2 EN 50081-1
Display:	LCD 4-digit, 6 mm [0.236"] high	Working temperature:	0 ... +50 °C [32 ...122 °F]
Count range:	9999 with zero blanking	Storage temperature:	-10 ... +60 °C [14 ... 140 °F]
Count input:	max. count frequency 18 Hz counting by closed contact	Housing:	clear and black
0 reset:	quick removal or the battery or connect the two pins on the back of the unit	Protection:	IP 40
		Weight:	7.5 g [0.265 oz]
		Electrical connections:	Flying leads 18 cm [0.591 feet] long

### Dimensions:

without housing

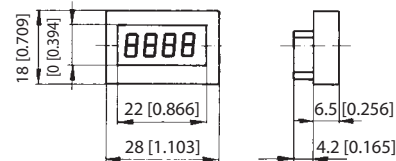

Flying leads  
180 mm [7.087"] long

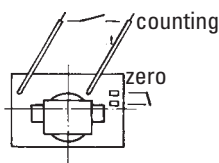

### Application

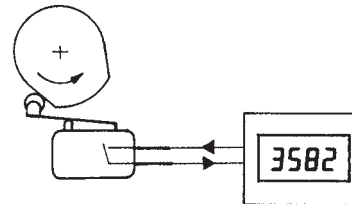

Control with contact

with housing

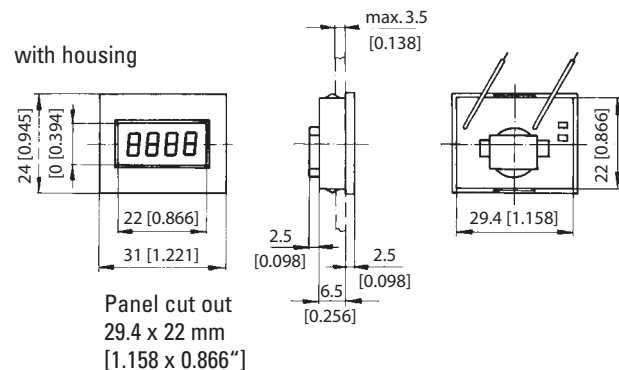

### Order code:

Art. no.: 0.166.012.830\*

### Delivery specification:

LCD module  
 Operating manual

\* standard stock model

## 6 digit LCD module 167/168



- 6-digit LCD display counter for panel or PCB mount (removable mounting)
- 3 V DC power supply
- Current consumption <math>< 5 \mu\text{A}</math> (- Inputs TTL/CMOS compatible
- Electrical zero reset

### Type 167:

count mode: adding

### Type 168:

count mode: adding/subtracting

1 count input

1 direction input

### Applications:

simple counting  
position-, length- and distance  
measurement, PCB counter

### Technical data:

Power supply:	2.6 ... 3.4 VDC
Current consumption:	typical 5 $\mu\text{A}$ , 10 $\mu\text{A}$ at 10 kHz
Display:	LCD, 6-digit, 6 mm [0.236"] high
Count range:	999 999
Overflow	
Type 167:	from 999 999 to zero
Type 168:	adding from 999 999 to zero subtracting from zero to 999 999
Count input:	max. count frequency 10 kHz min. pulse time 50 $\mu\text{s}$ negative triggered (NPN)
0 reset:	min. pulse time 15 ms negative triggered (NPN)

Direction input (Only Type 168): switch to 0 V or negative triggered (NPN)

Open input: count mode adding

Input to zero: 0 V: count mode subtract.

Interference resistance: EN 50081-1

Emitted interference: EN 55022 class B

Working temperature:  $-10 \dots +60 \text{ }^\circ\text{C}$  [ $14 \dots 140 \text{ }^\circ\text{F}$ ]

Storage temperature:  $-10 \dots +60 \text{ }^\circ\text{C}$  [ $14 \dots 140 \text{ }^\circ\text{F}$ ]

Housing: clear and black

Protection: IP 40

Weight: 7.5 g [0.265 oz]

Electrical connection: PCB pin  $\varnothing$  0.4 mm [0.016"]

### Dimensions:

without housing

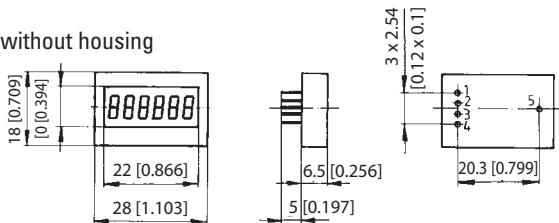

with housing

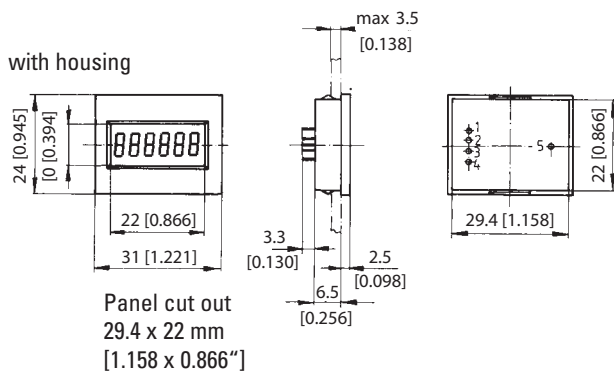

### Applications:

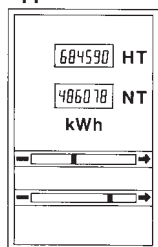

kWh counter

7/2007

### Connections:

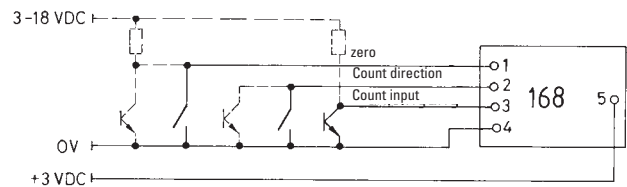
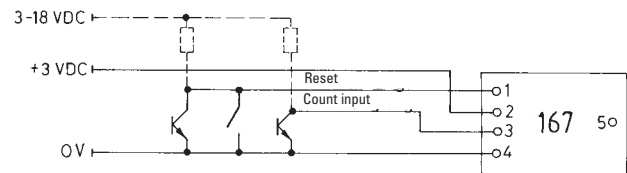

Pin-No.	Function	
	Type 167	Type 168
1	Reset	Reset
2	+ 3 VDC	Count direction
3	Count input	Count input
4	0 V	0 V
5	0 V	+3 VDC

### Order code:

Type 167: 0.167.012.000\*

Type 168: 0.168.012.000\*

### Delivery specification:

LCD module

Operating manual

\* standard stock model

## 8 digit count module type 180 with LCD display



### Your benefit

- Small dimensions
- PCB mount
- Low current consumption, for battery

### Product features

- With manual and/or manual and electrical reset
- Using a lithium battery with 1000 mAh the life is more than 10 years
- CMOS and TTL compatible

### Technical data:

Power supply:	3 V (+0.2, -0.6 V) DC
Display:	LCD, 8-digit, figures 8 mm [0.315"] high
Counting system:	adding or subtracting
Inputs:	
Fast count input:	Max. count frequency, 10 kHz, min. pulse time 50 $\mu$ s Input resistance 1 M $\Omega$ Switching level: Low: <0.7 V DC High: <2.5 V – UB (without R*) positive triggered see connection diagram
Slow count input:	Max. count frequency, 40 Hz min. pulse time 13 ms Input resistance 1 M $\Omega$ Switching level Low: <0.7 V DC High: <2.5 V – UB , negative triggered
Count direction:	static input, subtracting count as long as the input is 0.

Reset input:	static input, i.e. no count as long as the input is active. Please note: the reset input will be active, when switching to 0 V
min. pulse time	12 ms
Input resistance	1 M $\Omega$
Switching voltage	1.4 V negative triggered
Interference resistance:	EN 50081-1
Interference emission:	EN 55022 class B
Housing colour:	black
Connections:	1 fast count input 2 slow input D count direction R reset +, – Power supply
Type:	180.2: module with electrical reset 180.3: module with manual and electrical reset

### Dimensions:

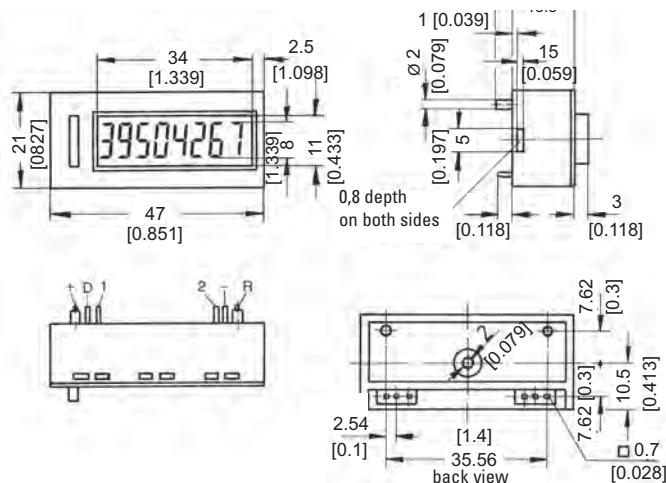

### Connections:

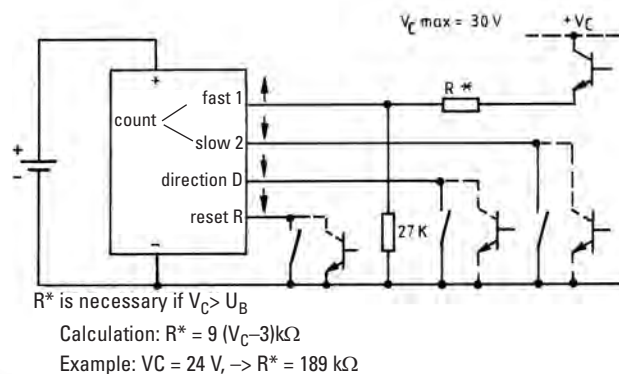

### Order code:

Module with electrical reset  
Module with manual and electrical reset

Order-No.: 0.180.200.000\*  
Order-No.: 0.180.300.000\*

\* standard stock model



## SSI-Display Type 570



### Your benefit

- AC and DC supply voltage in one unit
- Master- or slave mode
- Plug-in screw terminals
- SSI-clock frequency from 100 Hz up to 1 MHz
- Display and outputs may be adjusted using scaling- and offset-features
- Large 15 mm [0.591"] high LED-display, 6-digit, with adjustable brightness

### Product features

- Qualified for SSI-protocols up to 25 Bit
- Version with 2 optocoupler outputs to work as limit or preset values; also with programmable tracking preset.
- Version with scaleable analogue output, resolution 14 Bit, 0 ... 10 V, -10 ... +10 V, 0 ... 20 mA or 4 ... 20mA
- Grey- or binary-code
- 48 x 96mm [1.89 x 3.78"] DIN-housing, IP 65

### Technical data:

Supply voltage:	17 ... 30 V DC
Display:	15 mm [0.591"] high LED-display, 6 digits
Current consumption [DC]:	17 V: 190 mA; 24 V: 150 mA; 30 V: 120 mA
Power consumption [AC]:	7.5 VA
Sensor power supply:	24 V DC ± 15%, 120 mA
<b>Inputs:</b>	
SSI-input frequency range:	100 Hz ... 1 MHz
Input reset:	PNP or NPN, programmable 5.1 mA 24 V DC/ R <sub>i</sub> = 4.7 kOhm
Input level:	Low: 0 ... 2 V High: 9 ... 35 V
Reset time:	min. 5 ms

<b>Outputs:</b>	
Scaleable analogue output (0.570.012.E90):	0 ... 10 V, -10 ... +10 V or 0 ... 20 mA, 4 ... 20mA
Resolution:	14 Bit + Sign
Accuracy:	0.1 %
Optocoupler output: (0.570.012.E05)	5 ... 35 V DC/150 mA
Interface:	RS232 and RS 485 to ISO 1745 Drivecom Protocol
Operating temperature:	0 ... +45 °C [32 ... 113 °F]
Storage temperature:	-25 ... +70 °C [-13 ... 158 °F]
Protection class:	IP 65 front side
EMC:	according to EC EMC directive 89/36/EWG
Interference emission:	EN 6100-6-3/EN 55011 class B
Interference resistance:	EN 6100-6-2
Weight:	approx. 200 g [7.055 oz]

### Dimensions:

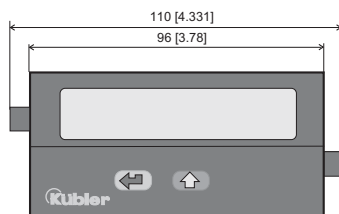

Panel cut-out: 92 x 45 mm [3.622 x 1.772]

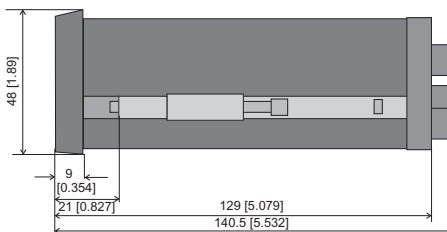

Display with serial interface (0.570.012.E05)

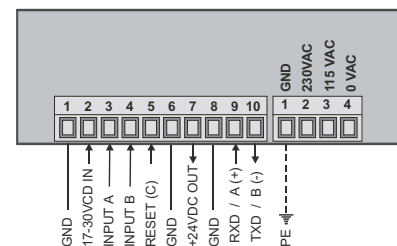

### Wiring diagram:

Display with analogue output (0.570.012.E90)

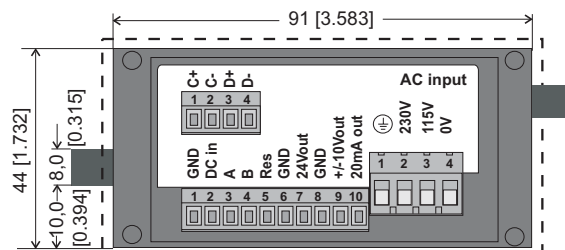

Display with 2 optocoupler outputs (0.570.011.E00)

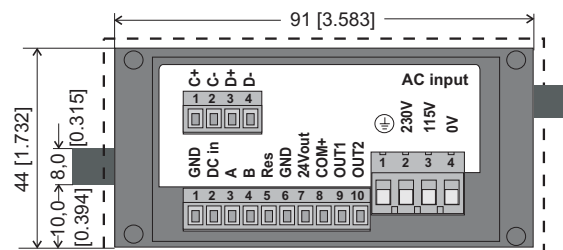

Do not connect A, B; C+, C- = clock signal SSI; D+, D- = data signal SSI

### Delivery specifications:

- SSI-Display
- Seal
- Mounting kit
- Plug-in screw terminals
- Manual German/English

### Order code:

- Display with 2 outputs: 0.570.011.E00\*
- Display with analogue output: 0.570.012.E90\*
- Display with ser. interface: 0.570.012.E05

\* standard stock model

## Display Type 571



### Your benefit

- AC and DC supply voltage in one unit
- Measuring function can be programmed for RPM, speed (from elapsed time), machine cycle time, throughput and baking time (time interval), as well as numerous count and stop-watch functions
- Scalable display, programmed via 2 keys
- Large 15 mm [0.591"] high LED-display, 6-digit, with adjustable brightness

### Product features

- Fast count input, works with our **LIMES** measuring system (100KHz)
- Version with 2 optocoupler outputs for alarms
- Version with analogue output, resolution 14 Bit: 0 ... 10 V, +10 V ... -10 V, 0 ... 20 mA, 4 ... 20 mA
- Version with serial interface RS232/485 for importing and exporting data
- 48 x 96 mm [1.89 x 3.78"] DIN housing, IP 65

### Technical data:

Supply voltage:	16 ... 35 V DC (Normal voltage: 24 V DC) 115/230 V AC $\pm$ 12,5 %
Display:	15 mm [0.591"] high LED-display, 6 digits
Current consumption [DC]:	18 V: 120 mA; 24 V: 95 mA; 30 V: 80 mA
Power consumption [AC]:	7.5 VA
Sensor power supply:	24 V DC $\pm$ 15%, 120 mA (at AC and DC supply)
<b>Inputs:</b>	3 Inputs (PNP, NPN and Namur) A, B = Impulse, C = Reset
Max. input frequency:	A, B = 25 kHz (100 kHz at count); C = 1 kHz
(Accuracy:	$\pm$ 1 ppm $\pm$ 1 digit
Input level HTL:	Low: 0 ... 3,5 V High: 9 ... 35 V

<b>Outputs:</b>	
Analogue-Output: (0.571.012.E90)	0 ... +10 V, 0 ... -10 V and 0 ... 20 mA, 4 ... 20mA
Resolution:	14 Bit + Sign
Accuracy:	0,1 %
Optocoupler-Output: (0.571.011.E00)	5 ... 35 V DC/150 mA
Interface (0.571.012.E05)	RS232 and RS485 acc. to ISO 1745 Drivecom Protocol
Operating temperature:	0 ... +45 °C [32 °F ... 113 °F]
Storage temperature:	-25 ... +70 °C [-13 °F ... 158 °F]
Protection:	IP 65 front side
EMC:	according to EC EMC directive 89/36/EWG
Interference emission:	EN 50081-2/EN 55011 class B
Interference resistance:	EN 6100-6-2
Weight:	approx. 200 g [7.055 oz]

### Dimensions:

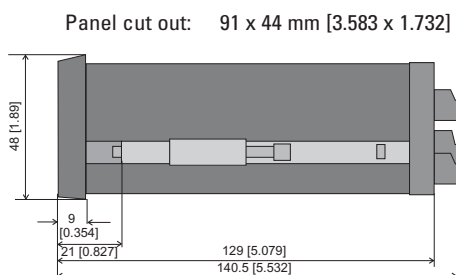
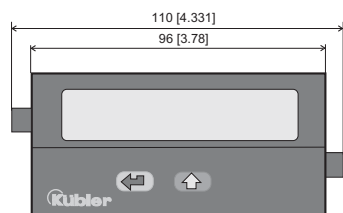

Display with serial interface (0.571.012.E05)

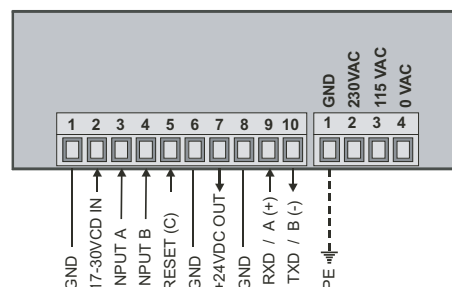

### Terminal assignment:

Display with analogue output (0.571.012.E90)

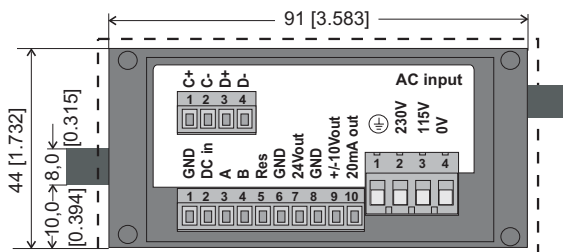

Display with 2 optocoupler outputs (0.571.011.E00)

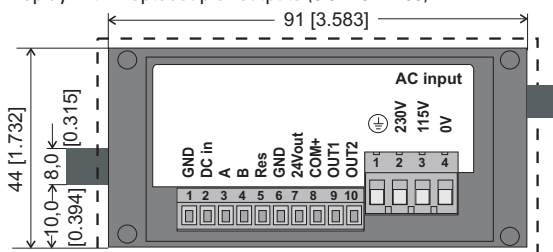

### Delivery specifications:

- Display 571
- Seal
- Mounting kit
- Plug-in screw terminals
- Manual German/English

### Order data:

- Display with 2 outputs Order code: 0.571.011.E00\*
- Display with analogue output Order code: 0.571.012.E90\*
- Display with ser. interface Order code: 0.571.012.E05

\* standard stock model





**Table of Contents**

Type of counters		Series	Display	Panel cut-out W x H [mm]	without	Reset man.	electr.	Remarks	Page
<b>Preset counters electronic</b>	LCD Preset counter	901	999999	45 x 45	–	•	•	Panel mount, AC or DC-supply with options	126
		923/924	999999	45 x 45	–	•	•	Panel mount, supplied by battery	128
		903/904	999999	45 x 45	–	•	•	Panel mount, AC or DC-supply	134
	LED Preset counter	715	999999	45 x 45	–	•	•	Panel mount, AC or DC-supply	137
		Codix 716/717	999999	45 x 45	–	•	•	Panel mount , also with Ex or interface	140
	LED Position display	571	999999	92 x 45	–	•	•	Panel mount multifunctions	144
<b>Preset counters electromechanical</b>	BVa 15	99999	50 x 50	–	•	–	Panel mount	145	
	MVs 13	999	50 x 33.3	–	•	•		149	
	MVs 16	999999	50 x 50	–	•	•		152	

Preset counters

## Preset counter Type 901



### Your benefit

- Replacement for electromechanical preset counters
- No power supply necessary (battery-operated)
- Count and reset input electrically separated from counter through optocoupler input range 12 ... 250 V AC/DC
- 2 line LCD display count, preset and level of the relay output
- Screw terminal
- approval

### Further product features

- Data security, thanks to exchangeable lithium batteries, life time minimum 8 years
- Easy programming
- Counter presets easily via presetting keys allocated to each decade

### Output

Potential free relay, programmable normally open or normally closed contact

### Technical data:

Power supply:	2 pcs user exchangeable lithium-batteries Type 1/2 AA lithium 3.6 V	max. switching voltage:	250 V AC/220 V DC
Display:	2 line LCD display, 6 digits: 999999 height of figures 7 or 4.5 mm [0.276 or 0.177"]	max. switching current:	2 A
Input:	reset, count and key lock inputs	max. switching capacity:	60 VA/30 W
Polarity of the inputs:	bidirectional optocoupler input for the reset and count inputs Reset, count and keyboard lock is connected to +3 V DC	Output response time:	< 20 ms, max. 4 Hz
Min pulse duration of the inputs:	reset input: 50 ms keyboard lock input: 15 ms	Data retention:	via 2 batteries; 8 years at $5 \times 10^6$ power operations of the output relay and an ambient temperature of 25 °C [77 °F]
Switching levels of the inputs:	low: < 3 V AC/DC high: 12 ... 250 V AC/DC	Ambient temperature:	-10 ... +50 °C [14 ... 122 °F]
Input frequency:	max: 25 Hz	Storage temperature:	-25 ... +60 °C [-13 ... 140 °F]
Input resistance:	110 kΩ	EMC:	according to EC EMC directive 89/36/EWG
Output:	bistable relay with potential free contact (programmable as normally closed or normally opened contact)	Emitted interference:	EN 61 000-6-4/EN 55011 class B
		Immunity to interference:	EN 61 000-6-2
		UL:	File E128604
		Protection:	IP 65 front side
		Weight:	approx. 80 g [2.822 oz]

### Programming:

The counter is programmed using the keys on the front. The menu is shown on the display. The following modes are programmable:

1. Count mode (adding or subtracting)
2. Latch or automatic cycle
3. Output (normally open or normally closed)
4. Display Hold during automatic cycles in steps of 100 ms between 100 and 500 ms.
5. Decimal point up to max. 3 decimal places.

### Function of the output:

Adding:

Relay is active, when actual value  $\geq$  preset

Subtracting:

Relay is active, when actual value  $\leq 0$

When the relay is active a colon will appear at the bottom left of the display.

### Operating the counter:

Setting or resetting:

Press the red SET button or apply a pulse to the reset input to set the counter to zero in the adding mode or to the preset in the subtracting mode.

### Presetting:

The preset value is indicated on the lower row of digits. To set it, use the 6 presetting buttons assigned to each decade. The set value will be accepted with the next set or reset operation.

### Overflow and underflow:

In the adding mode the overflow is 999 999 to 0; in the subtracting mode it is 0 to 999 999. The output signal remains unaffected.

### Lo-Bat-indicator:

When the battery charge is too low, **Lo-bat** appears in the lower display. This flashes on a two second cycle. When lo-bat is indicated, the battery should be changed as soon as possible.

### Changing the battery:

Push the battery cover back and remove the batteries, making certain that polarity is correct. (observe “-” terminal on PCB)  
**Note:** Changing the battery should not take longer than 2 min. otherwise, the count and preset values, as well as the parameters will get lost and therefore must be set again.

## Preset counter Type 901

### Terminal block:

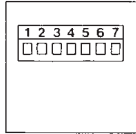

### Example of connection:

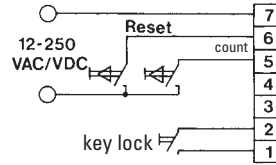

Pin	
1	+3 V DC for terminal 2
2	Keyboard lock-input
3	Relay contact
4	Relay contact
5	AC/DC optocoupler count input
6	AC/DC optocoupler reset input
7	Common AC/DC input for terminal 6 and 5

### Dimensions:

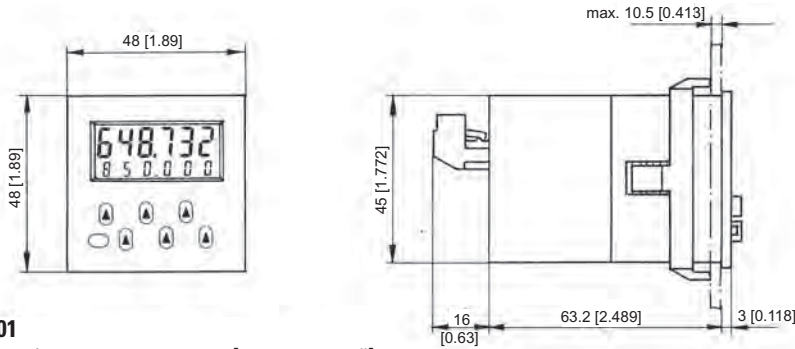

**901**  
Panel cut-out 45 x 45 mm [1.772 x 1.772"]

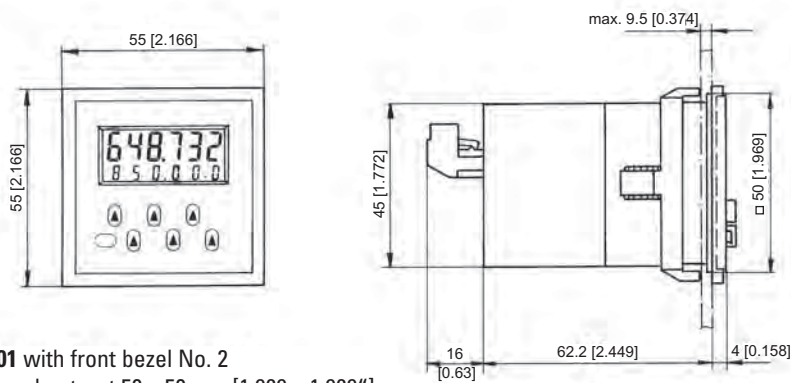

**901 with front bezel No. 2**  
Panel cut-out 50 x 50 mm [1.969 x 1.969"]

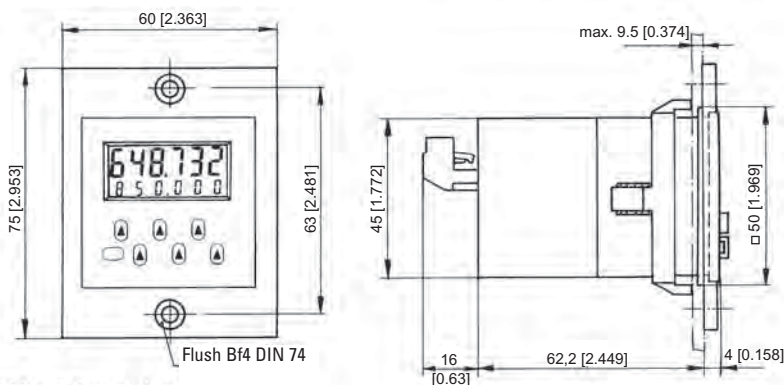

**901 with front bezel No. 3**  
Panel cut-out 50 x 50 mm [1.969 x 1.969"]

### Delivery specification:

- Counter 901
- 2 Lithium batteries
- 1 Screw terminal
- 1 Front bezel for screw mounting  
Panel cut-out 50 x 50 mm [1.969 x 1.969"]
- 1 Front bezel for spring clip mount  
Panel cut-out 50 x 50 mm [1.969 x 1.969"]
- 1 Spring clip
- 1 Template for panel cut-out
- 1 Operating instruction

**Order Code:** 6.901.010.800\*

\* standard stock model

## Universal Preset Counter *CODIX 923 / 924*

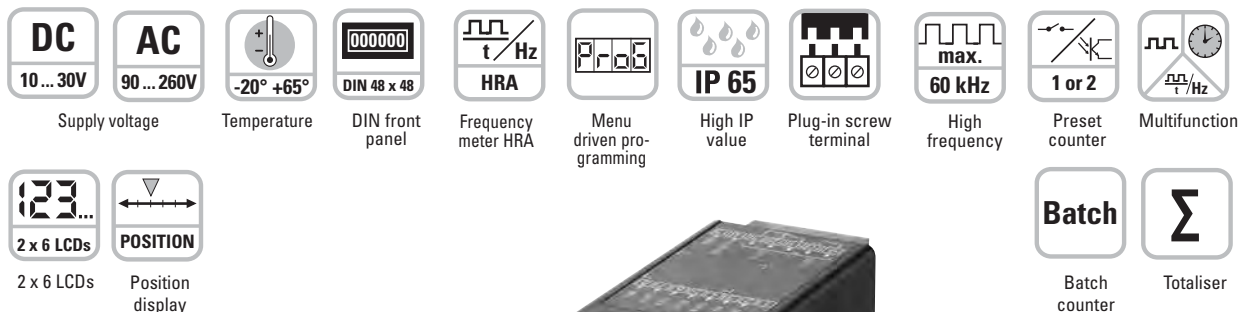

### Multifunction:

- Counter, Tachometer and Timer – all in one device
- Can be used as preset counter, batch counter or totaliser (overall cumulative count)
- 1 or 2 presets (additional presets on request)
- Relay or optocoupler outputs
- Wide choice of count modes for pulse inputs, time or frequency
- Averaging, start delay (Tachometer)
- Scalable display with multiplikation and division factor, set value
- Step or tracking presets

### Fast:

- Direct input of the presets via the front keys or the Teach-In input
- Fast installation thanks to plug-in screw terminals and integrated sealing gaskets
- Max. count frequency 60 kHz

### User-friendly:

- Simultaneous display of the actual value, presets, batch count or total count
- Annunciators for the displayed preset and for the output status
- 3 predefined settings for the most common parameter settings
- Direct entry into the programming
- Tracking presets eliminate the need for reprogramming of the pre-signal
- Minimum installation depth
- 4 stage RESET modes
- 3 stage key lockout

### Technical data:

Supply voltage:	90 ... 260 V AC/max. 8 VA, 50/60 HZ, External fuse protection T 0.1 A 10 ... 30 V DC/max. 1.5 W External fuse protection T 0.2 A	
Display:	2-line 6-digits LCD display LCD pos. (green) backlighting	
Count inputs:	Polarity of the inputs: programmable for all inputs in common NPN/PNP Input resistance: 5 k $\Omega$ Count frequency: max. 55 kHz (details see manual) Min pulse duration of the inputs: 10 ms / 1 ms	
Switching levels with AC-supply:	HTL-level: Low: 0 ... 4 V DC High: 12 ... 30 V DC 5 V-level: Low: 0 ... 2 V DC High: 3.5 ... 30 V DC	
Switching level with DC-supply:	HTL-level: Low: 0 ... 0.2 x U <sub>B</sub> High: 0.6 x U <sub>B</sub> ... 30 V DC 5 V-level: Low: 0 ... 2 V DC High: 3.5 ... 30 V DC	
Pulse shape:	variable, Schmitt-Trigger characteristics	
Output	Switching voltage	max. 250 V AC/110 V DC
	Switching current	max. 3 A AC/A DC

Output 1	Switching current	min. 30 mA DC
	Switching capacity	max. 750 VA/90 W
	Mech. service life (switching cycles)	2 x 10 <sup>7</sup>
	N° of switching cycles at 3 A/250 V AC	1 x 10 <sup>5</sup>
	N° of switching cycles at 3 A/30 V DC	1 x 10 <sup>5</sup>
	Relay closing contact, programmable as normally open (NO) or normally closed (NC)	
Output 2	Mech. service life (switching cycles)	20 x 10 <sup>6</sup>
	N° of switching cycles at 3 A/250 V AC	5 x 10 <sup>4</sup>
	N° of switching cycles at 3 A/30 V DC	5 x 10 <sup>4</sup>
	Relay with changeover contact	
or npn optocoupler:	switching power	30 V DC/10 mA
	U <sub>CESAT</sub> at IC = 10 mA:	max. 2.0 V
	U <sub>CESAT</sub> at IC = 5 mA:	max. 0.4 V
Reaction time of the outputs:	Relay:	approx 7 ms
	Optocoupler:	approx 1 ms, Details see instruction manual
Response time of the frequency counter:	100/600 ms, Details see instruction manual	
Data retention:	min. 10 years, EEPROM	
Count modes:		
Pulse counter:	cnt.dir, up.dn, up.up, quad, quad 2, quad4, A/B, (A-B)/A x 100%	
Frequency counter:	A, A-B, A+B, quad, A/B, (A-B)/A x 100%	
Timer:	FrErun, Auto, InpA.InpB., InpB.InpB.	



### Technical Data:

Voltage supply for sensors:	
AC supply	24 V DC ± 15%, 80 mA
DC supply	max. 80 mA, external voltage supply is connected through
Operating temperature:	-20 °C ... +65 °C
Storage temperature:	-25 °C ... +75 °C

Humidity:	RH 93% at +40 °C, non-condensing
EMC:	CE compliant to EU directive 89/36/EWG
Standards:	EN 61 000-6-4/EN 55011 class B EN 61000-6-2
UL (applied for):	File-N°.: E128604
Protection:	IP65 (front)
Weight:	approx. 125 g

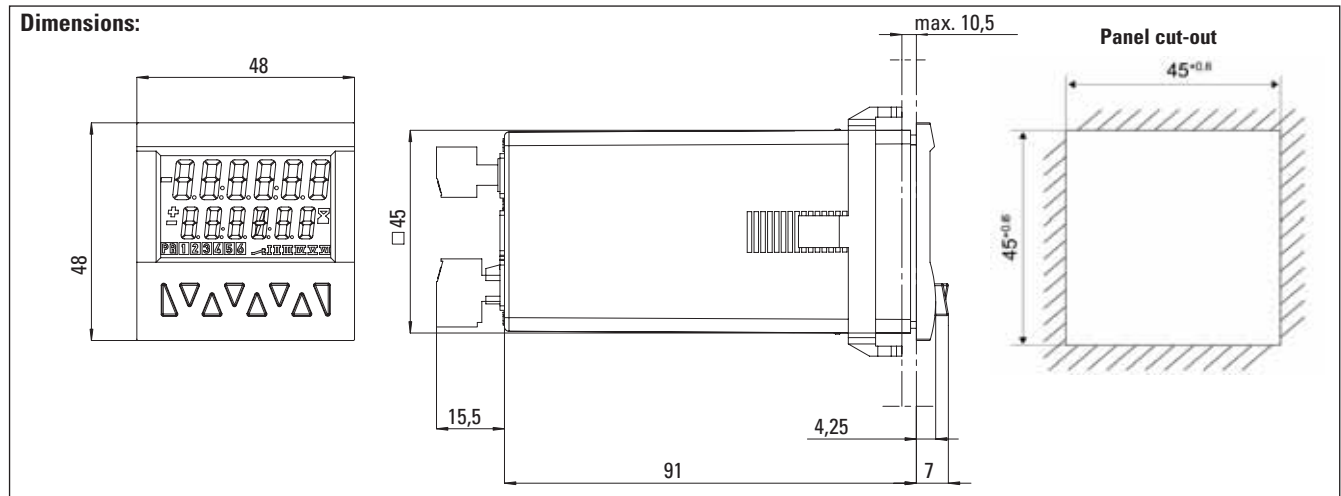

Preset counters

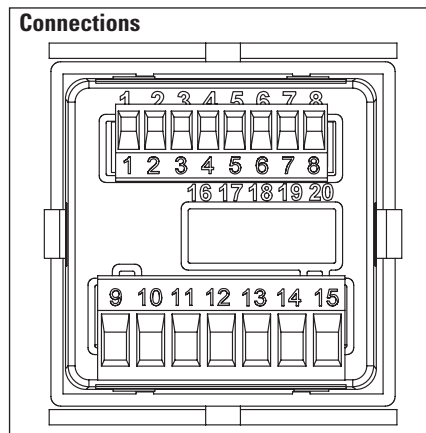

#### Signal and control inputs

- 1 Sensor voltage supply  
AC: 24 VDC/80 mA  
DC: UB interconnected
- 2 GND (0 VDC)
- 3 INP A (Signal input A)
- 4 INP B (Signal input B)
- 5 RESET (Reset input)
- 6 LOCK (Key locking input)
- 7 GATE (Gate input)
- 8 MPI (User input)
- 16 ... 20:  
Additional optional inputs or outputs or interfaces

#### Version with relays/optocouplers

- 9 Relay contact C./Collector } Output 1
- 10 Relay contact N.O./Emitter }
- 11 Relay contact C./Emitter }
- 12 Relay contact N.O./not assigned } Output 2
- 13 Relay contact N.C./ Collector }
- 14 AC: 90..260 VAC N~ } Supply voltage
- 15 DC: 10..30 VDC }
- DC: 90..260 VAC L~ }
- DC: GND (0 VDC) }

#### Delivery specification:

- Preset counter
- Mounting clip
- Operating instructions

#### Order code:

Number of presets	3 = 1 preset 4 = 2 preset
Outputs	0 = Relays 1 = Optocouplers (only 924)
LCD options	0 = no backlighting 1 = green backlighting

**6.92X.01XX.XX0**

Input trigger level	0 = Standard level (HTL) A = 5 V-level
---------------------	---

Supply voltage	0 = 90–260 V/AC 3 = 10–30 V/DC
----------------	-----------------------------------

Options: Additional inputs or outputs or interfaces on request

Standard stock models:

6.923.0100.000	6.924.0100.000
6.923.0100.300	6.924.0100.300

## Areas of application for 923/924:

### ■ Pulse counter

#### Functions/ Count modes

- Count with direction mode
- Difference mode
- Quadrature mode quad/quad2/quad4
- Add, Sub, automatic reset
- 2-input adding mode A+B
- Ratio measurement A/B
- Percentage difference measurement  $(A-B)/A \times 100\%$
- Batch counting
- Totaliser (Overall total)
- Multiplication and division factor (up to 99.999)
- Set value
- Step or tracking preset

#### Application examples

##### CountDir

Roller shutter door with automatic shutoff

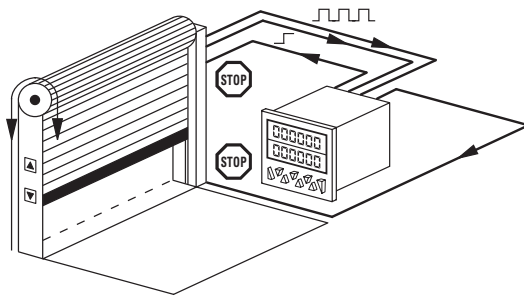

##### Quad

Running direction and position on milling machines

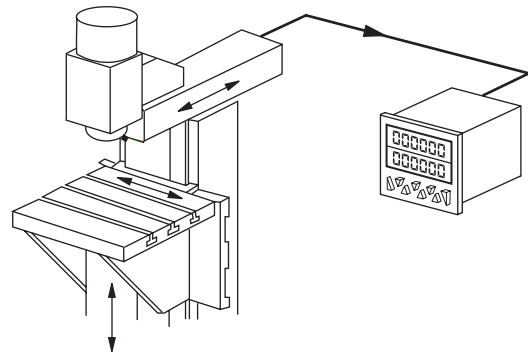

##### UpDown

Automatic subtraction of faulty or reject parts from the total piece count

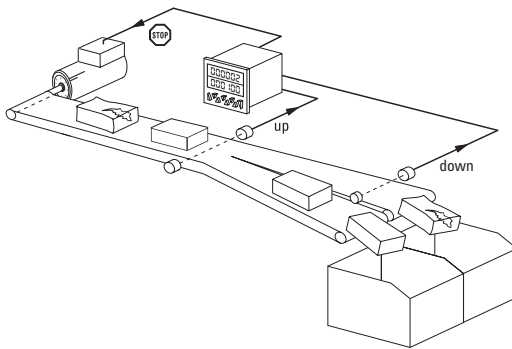

##### Batch

Logging of piece numbers and packing units plus control of replenishment of packing cartons

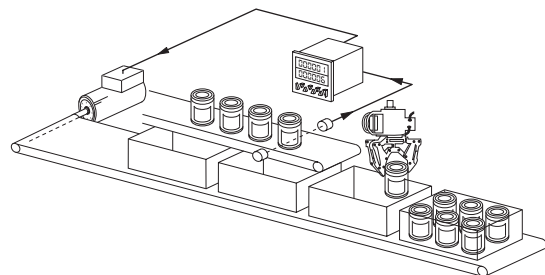

##### UpUp

Adding up of two parallel or staggered production lines

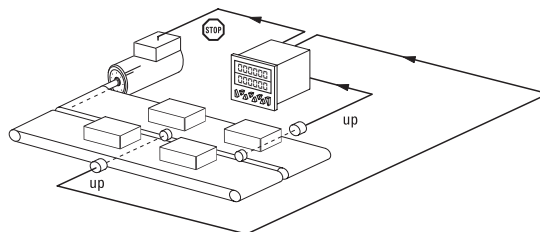

##### Add tot

Cut-to-length with overall total count

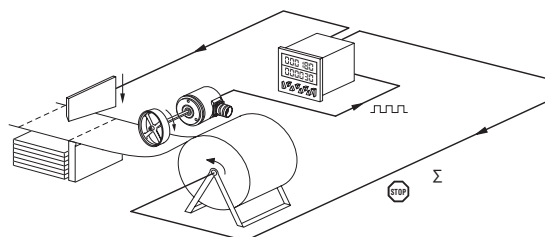

## Areas of application for 923/924:

### ■ Frequency counter (Tachometer)

#### Functions/ Count modes

- A
- B
- A - B
- A + B
- A / B
- (A - B) / A x 100 % (percentage display)
- Quad (Phase discriminator with recognition of direction)
- Averaging
- Start delay
- 2nd tacho input
- Gate input
- Multiplication and division factor (up to 99.9999)

<b>Application examples</b>	<b>A - B</b> Synchro monitoring and control of two conveyor belts 	<b>Speed regulation with indication of direction</b> 
	<b>Ratio measurement A/B</b> 	<b>Ratio measurement e.g. for speed alignment</b> 

Preset counters

### ■ Time and hours-run meter (Timer)

#### Functions/ Count modes

- FrErun (Control via gate input)
- Auto (Start via Reset, Stop at preset)
- InpB.InpB (Start with first edge at InpB., Stop with second edge InpB.)
- InpA. InpB (Start with InpA., Stop with InpB.)
- Totaliser (Overall total)
- Batch counting
- Set value
- Step or tracking preset

<b>Application examples</b>	<b>Interval measurement InpB. InpB</b> 	<b>FrErun</b> Measurement of overall time from switching on the conveyor belt till switching off 
	<b>Run-time measurement InpA. InpB.</b> 	<b>Auto</b> time-controlled production line 

## Universal Preset Counter **CODIX 923/924**

Your control solution, ready-to-go · very easy to operate ·  
direct display · expandable via module individual functionality.



### Multifunction

More than just preset counters: the **CODIX 923/924** are multi-talented and can handle the display, measurement and control of pulses (counter), frequencies (tacho) and time (timer) using numerous count functions and modes.

**Open to many applications.** The great advantage of the **CODIX 923/924** preset counters: they offer a simple and cost-effective solution for many local standard control functions. It is not necessary to have in-depth programming knowledge when installing or using the product, which does away with the need for costly service engineers.

### Expandable

Numerous logic functions and preconfigured, selectable operating modes for a variety of applications, including for example positioning and batch counting, make the counter a real alternative to a PLC – and with the benefit of a display included.

The devices are so designed that they are expandable for OEM applications. Both hardware and software can be modified and expanded. PCB-board receptacles are provided in the counter for hardware upgrade purposes:

- Up to 10 inputs
- Up to 6 optocoupler outputs
- Up to 4 relay outputs
- Interface RS 232/485
- Individual functions

The software can be specifically customised to OEM applications. This includes the logic behaviour of the inputs and outputs (I/O functionality) or the whole display unit.

Expandable on request via modules:

- 4 additional inputs
- or 4 additional optocoupler outputs
- or 2 additional relay outputs
- or RS 232/485 interfaces

Application examples:

- Limit switch monitoring
- Special functions/PLC function
- Initiation of fixed program sequences
- Control of several processes
- Special protocols
- Print commands for logging

Individual customisation of software to your application.

For example:

- Separate inputs for total counter and preset counter
- Separate scaling of input A and B
- Programmable measuring period for the tachometer
- Measurement of rotary speeds based on time
- Processing time, measurement of time based on frequency

#### Expandable hardware:



#### Customisable software:



#### With your logo:



Free-of-charge for 100+ pcs.

Typically a simple OEM customisation is worthwhile for annual quantities of 20-50 pcs. We would be happy to solve this task for you quickly, professionally and economically.  
Phone +49 (0) 77 20 - 39 03-38  
or info@kuebler.com

## Universal Preset Counter **CODIX 923 / 924**

### User-friendly



*Fresh, modern design that further enhances your panel or equipment.*

**Simple filing-cabinet programming structure** for fast entry of parameters. Quickly operational: after each parameter has been modified, it is possible to exit the programming by means of the reset key.

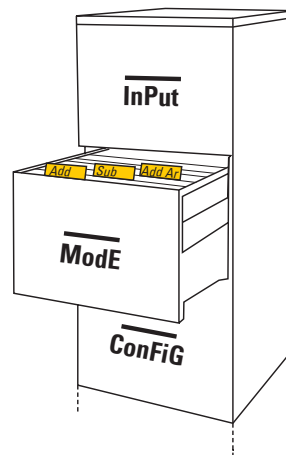

**Convenient time-saving installation:** Plug-in screw terminal connections with cage clamp terminals. IP 65 sealed front bezel as standard. Saves additional time & effort for protection when installing. Minimal installation depth – will fit anywhere.



**Comprehensive, large display:** 2-line, 2 x 6-digit LCD display with sign, leading zero suppression, giving a display range from -999 999 to +999 999. Optional backlighting for good readability in all situations.

**Easy-to-operate** without programming knowledge. Direct access to the programming mode for all count functions. User-friendly, thanks to the simplified programming structure and alpha-numeric display of the parameters.



**Easy-to-understand:** thanks to the use of annunciators for the displayed preset and the status of both outputs, as well as the simultaneous display of the actual value and the presets or the auxiliary counters.



**New: MPI input** (multiple purpose input) with the functions: Display Hold, Set and Teach-In.



**The compact decade key-pad:** allows for a large display and enables simple direct entry of the presets.

**Three predefined settings:** with parameter settings for the most common applications.

**Preset via Teach-In input:** for simple error-free entry of the preset. A reset key plus programming mode key are already integrated.



Preset counters

## Type 903/904



### Your benefit

- 2 line LCD display
- Programmable as impulse counter, frequency meter or time meter with sign and zero blanking
- Power supply  
90 ... 260 V AC or 10 ... 30 V DC
- approval
- Batch mode

### Further product features

- Display range -199 999 ... 999 999 with zero blanking
  - Easy to operate and set the preset values via 4 keys
  - Relay or optocoupler-output
  - Scaling factor 0.0001 ... 9.9999
- 903:** 1 preset value, 1 output  
**904:** 2 preset values, 2 outputs

### Technical data:

Supply voltage:	10 ... 30 V DC, max. 1,1 W with reverse polarity protection. 90 ... 260 V AC max. 4 VA
Display:	2 line LCD display, 6-digits
Count inputs:	2 count inputs, 4 input modes are programmable
Polarity of the inputs:	programmable for all inputs in common
Input resistance:	approx. 10 kΩ
Count frequency:	via DIL switches for INP A and INP B can be set separately 30 kHz 10 kHz for input modes E3 and E4 (quadrature) for automatic repeat - 900 Hz without losing counts (500 Hz for input mode E4)
Min. pulse duration of the inputs:	5 ms
Input sensitivity:	DC supply voltages: Low: 0 ... 0.2 x U <sub>B</sub> [V DC] High: 0.6 x U <sub>B</sub> ... 30 [V DC] AC supply voltages: Low 0 ... 4 V DC High 12 ... 30 V DC
Pulse shape:	variable (Schmitt-Trigger characteristics)
Output 1	Relay: with potential free contact, programmable as normally opened or normally closed. switching voltage max. 250 V AC/125 V DC, switching current max. 3 A. switching current at DC min. 30 mA switching power at DC 90 W at AC max. 750 VA

or npn optocoupler:	with open collector and emitter switching power 30 V DC/15 mA
Output 2	Relay: with potential free contact, programmable as normally open or normally closed. switching voltage max. 250 V AC/125 V DC, switching current max. 3 A switching current at DC min. 30 mA switching power at DC 90 W at AC max. 750 VA
or npn optocoupler:	with open collector and emitter switching power 30 V DC/15 mA
Reaction time of the outputs:	relay: approx. 7 ms optocoupler: approx. 1 ms
Data retention:	min. 10 years or 1x10 <sup>6</sup> memory cycles
Transmitter voltage:	24 V DC -40 %/+15 %, 100 mA at 90 .. 260 V AC with optional backlighting: 24 V DC -40 %/+15 %, 60mA at 90 ... 260 V AC
Ambient temperature:	0... +50 °C [32 ...122 °F]
Storage temperature:	-25 ... +70 °C [-13 ... 158 °F]
EMC:	according to EC EMC directive 89/36/EWG
Emitted interference:	EN 61 000-6-4/EN 55011 class B
Immunity to interference:	EN 61 000-6-2
UL:	File E128604
Protection:	IP 65 front side EX version IP 54
Weight:	approx. 240 g [8.466 oz], AC version with relay

### Inputs:

#### INP A, INP B

Count inputs: the max. count frequency of 10kHz can be damped for each channel to 30 Hz.

#### Gate

Static gate input; no counting while this input is activated

### Reset

Dynamic reset input; it is connected in parallel to the red reset key and sets the counter to zero (adding mode) or to the preset value (subtracting mode)

### Key

Static keyboard lock input; while this input is activated, the front keys are locked for operations

### Outputs:

2 potential free outputs (903: 1 output), versions with relay or optocoupler available

### Programming:

The types 903 and 904 are programmed via only 4 keys on the front side. Trouble-free and intuitive operation through clear text user guidance on the display. The operating parameters are chosen from a menu. The device can be used as:

1. Pulse counter
2. Frequency meter
3. Time meter

Therefore the following functions are programmable:

### Polarity of the inputs:

Positive (pnp) or negative (npn) polarity of the inputs. The selected polarity applies to all inputs.

### Operating modes, impulse counter and timer:

- adding, starting at zero
- subtracting, starting at the preset value (903) or at preset value 2 (904)
- adding with automatic reset to zero at preset value (903) or preset value 2 (904)
- subtracting with automatic reset to preset value (903) or preset value (904) at zero.

### Input modes, impulse counter and frequency meter:

- E1 1 count input, 1 count direction input
- E2 1 Count input up  
1 Count input down
- E3 Quadrature input  
to connect encoders with 2 signals shifted by 90°

- E4 Quadrature input with pulse doubling  
to connect encoders with 2 signals shifted by 90°

### Decimal places:

The display is possible with two or three decimal places

### Scaling factor:

For optimizing the operation with an encoder a scaling factor of 0.0001 ... 9.9999 may be programmed

### Output signal:

Selectable as NO contact or NC contact, positive or negative timed signal (duration 0.01 ... 99.99 s)

### Gate time for frequency meter:

Selectable from 0.01 ... 99.99 s

### Hour meter:

Timing in h, min or s, with a resolution of 0.001, 0.01, 0.1 or h:min:s

### Applications:

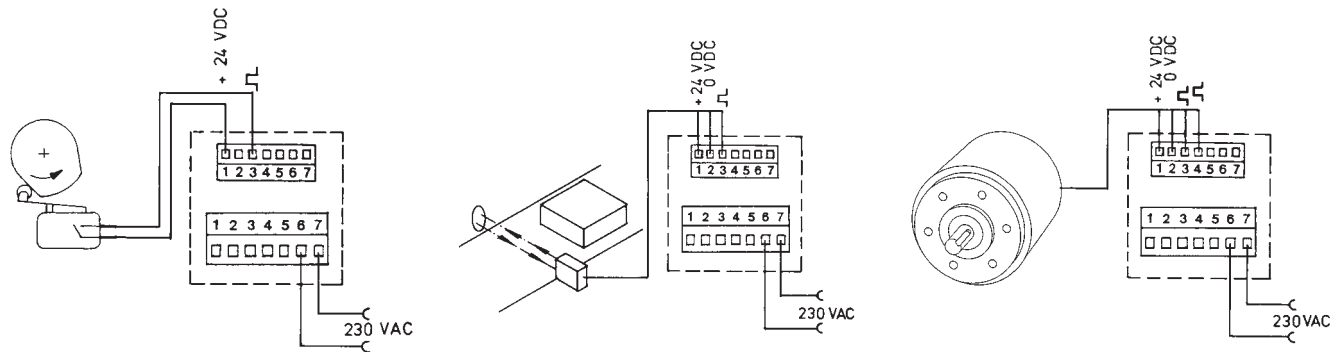

control via light barrier

control via encoder

### Connection diagram 904:

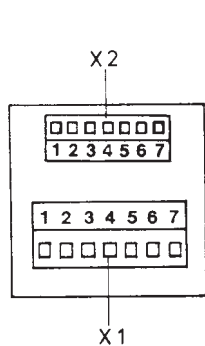

Pin connection X1:

Pin	AC version	DC version
1	Output 1 Relay collector at optocoupler output	
2	Output 1 Relay emitter at optocoupler output	
3	Output 2 Relay common contact (c) emitter at optocoupler output	
4	Output 2 Relay normally open (NO)	
5	Output 2 Relay normally closed (NC) collector at optocoupler output	
6	Supply voltage	
	90 ... 260 V AC	11 ... 30 V DC
7	90 ... 260 V AC	0 V DC (GND)

Pin connection X2:

Pin	Description	AC version	DC version
1	+24 V DC	Transmitter voltage supply	n.c.
2	0 V DC (GND)	GND	n.c.
3	INP A	Count input A	
4	INP B	Count input B	
5	Reset	Reset input	
6	Gate	Gate input	
7	Key	Key locking input	

**Dimensions:**

903/904

Panel cut-out 45 x 45 mm [1.772 x 1.772"]

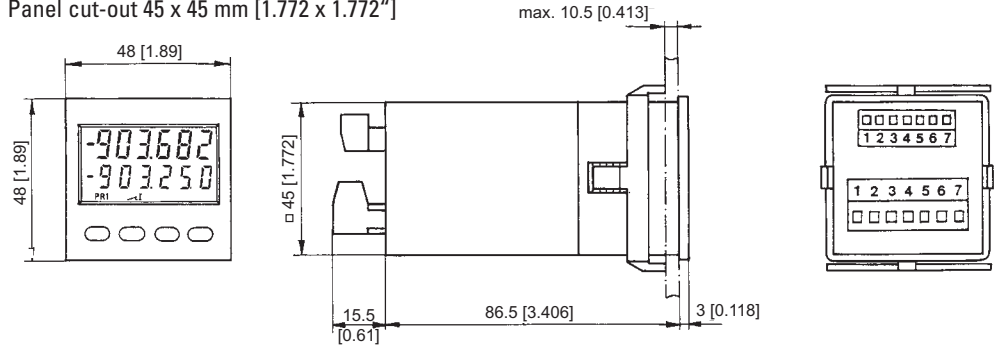

903/904 with front bezel no 2

Panel cut-out 50 x 50 mm [1.969 x 1.969"]

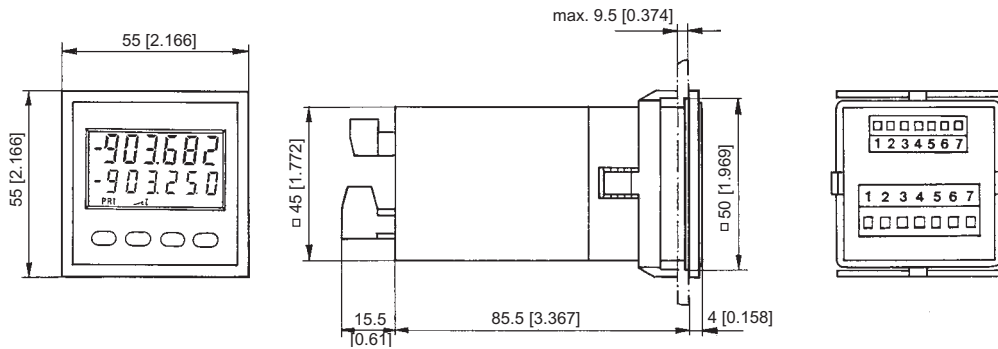

903/904 with front bezel no. 3

Panel cut-out 50 x 50 mm [1.969 x 1.969"]

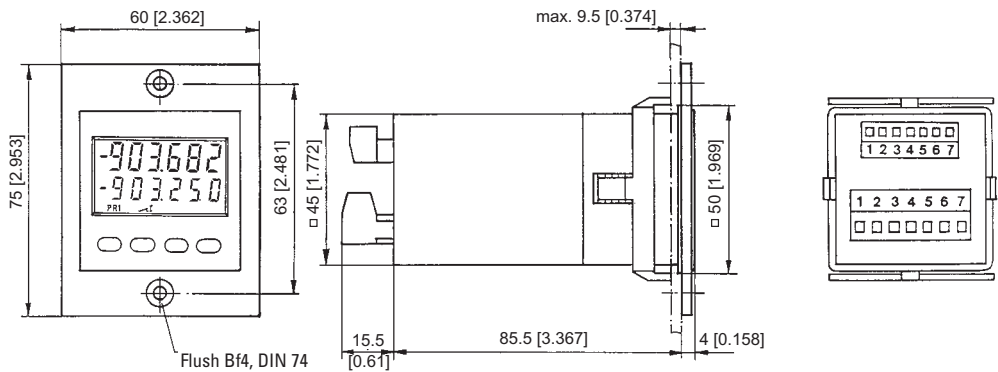

**Delivery specification:**

- Counter
- 2 Lithium batteries
- 1 Screw terminal
- 1 Front bezel for screw mounting  
Panel cut-out 50 x 50 mm [1.969 x 1.969"]

- 1 Front bezel for spring clip mount  
Panel cut-out 50 x 50 mm [1.969 x 1.969"]
- 1 Spring clip
- 1 Template for panel cut-out
- 1 Operating instruction

**Order code:**

**6.90X.01X.XXX**

**Type**  
 903 = Preset counter with one preset\*  
 904 = Preset counter with two presets\*

**Outputs**  
 0 = Relay\*  
 1 = Optocoupler

**Options**  
 00 = Without\*  
 10 = Backlit LCD\*

**Supply voltage**  
 0 = 90 ... 250 V AC\*  
 3 = 11 ... 30 V DC\*  
 5 V input level: order code: 6.XXX.01X.XXX.5V

\* standard stock model



## Type 715



### Your benefit

- 5-digit preset counter with one preset point, add./subtr.
- Bright 5-digit LED display with 7.5 mm [0.295"] high characters
- Programmable as pulse counter, frequency meter or timer
- Supply voltage: 230 V AC, 115 V AC or 11 ... 30 V DC
- approval

### Further product features

- Display range -19999 ... 9999 with zero blanking
- Easy programming of preset point; one key for each digit
- Relay or optocoupler output
- Prescaling factor 0.001 ... 9.999



### Technical data:

Supply voltage:	11 ... 30 V DC, with reverse polarity protection 115 V AC, 230 V AC	switching voltage max. 250 V AC/300 V DC switching current max. 3 A, switching current for DC min. 30 mA switching performance: max. 50 W for DC max. 2000 VA for AC
Current consumption:	max. 100 mA, 4 VA	
Display:	5-digit 7-segment red LED display 7.5 mm [0.295"] high characteristics	
Polarity of input signals:	programmable, all inputs in common	Optocoupler: with open collector and emitter switching performance max. 30 V DC, 15 mA
Input resistance:	approx. 10 kΩ	Relay: approx. 6 ms Optocoupler: approx. 1 ms
Count frequency:	via DIL switches separately selectable for INP A and INP B 30 Hz, 10 kHz (7.5 kHz for input mode E4) automatic reset 1 kHz without count losses (600 Hz for input mode E4)	Data retention: min. 10 Years or 10 <sup>6</sup> memory cycles
Min. pulse length of the control inputs:	5 ms	Transmitter voltage: 24 V DC -40 %/+15 %, 80 mA unregulated for AC versions
Input sensitivity:	DC supply voltages: Low: 0 ... 0.2 x U <sub>B</sub> [V DC] High: 0.6 x U <sub>B</sub> ... 30 V DC AC supply voltages: Low 0 ... 4 V DC High 12 ... 30 V DC	Ambient temperature: 0 ... +50 °C [32 ... 122 °F] Storage temperature: -25 ... +70 °C [-13 ... 158 °F]
Pulse shape:	variable (Schmitt Trigger characteristic)	Emitted interference: EN 61 000-6-4/EN 55011 class B Immunity to interference: EN 61 000-6-2
Output Relay:	with potential-free change-over contact	UL certified: File E128604 Protection: IP 65 front Weight: approx. 240 g [8.466 oz], (AC-version with relay)

Preset counters

### Applications:

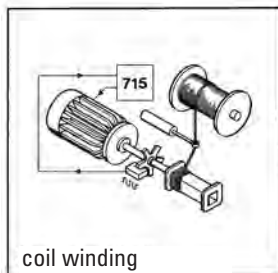
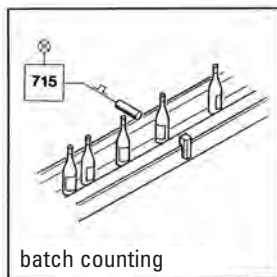
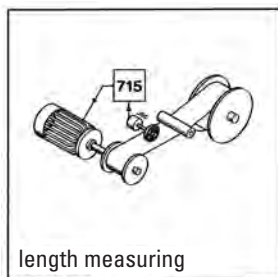

Operating modes			
Operating modes	Counting starts at	Output signal at count value	Kind of signal
1	0	≥ preset value	permanent or timed signal
2	preset value	≤ 0	permanent or timed signal
3	0	= preset value	timed signal and autom. reset
4	preset value	= 0	timed signal and autom. reset

## Selection of basic function

### 1. Pulse counter

- Mode:** see table  
**Decimal point:** 0 ... 3 decimal places (only optical function)  
**Polarity:** npn or pnp  
**Input modes:**  
 E1: One count input and one count direction input. While this input is not activated the counter adds, if it is activated the counter will subtract.  
 E2: Differential input, one up input and one down input  
 E3: Quadrature input for two lines of count pulses 90° out of phase. Up and down counting is automatic.  
 E4: Quadrature input with pulse doubling. Each pulse edge of count input "A" will be counted. Up and down counting is automatic.  
**Prescaling factor:** 0.001 ... 9.999  
**Output signal:** Permanent signal or timed signal selectable (0.01 ... 99.98 s)

### 2. Frequency counter

- Gate:** gate time selectable from 0.001 ... 99.99 s  
**Decimal point:** 0 ... 3 decimal places  
**Polarity:** npn or pnp  
**Input modes:** see pulse counter E1 ... E4  
**Scaling factor:** 0.001 ... 9.999  
**Output signal:** permanent or timed signal selectable (0.01 ... 99.98 s)

### 3. Timer

- Operating mode:** see pulse counter  
**Counting:** s, min or h;  
 resolution: 0.001; 0.01; 0.1 or 1.0  
**Polarity:** npn or pnp  
**Output signal:** permanent signal or timed signal (0.01 ... 99.98 s)

## Connection diagram:

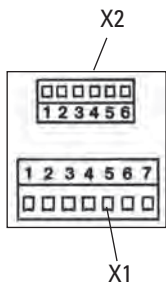

Plug connection X1:

Pin	115/230 V AC version	11 ... 30 V DC version
1	+24 V DC transmitter voltage	–
2	0 V DC (GND)	–
3	Relay output common contact (C) Optocoupler output Emitter	
4	Relay output normally open contact (NO)	
5	Relay output normally closed (NC) Optocoupler output collector	
6	115 V AC/230 V AC	11 ... 30 V DC
7	115 V AC/230 V AC	0 V DC (GND)

Plug connection X2:

Pin	Designation	Function
1	INP A	Count input A
2	INP B	Count input B
3	Gate	Gate input
4	Reset	Reset input
5	Latch	Display stop input
6	Key	Keyboard lock input

**Dimension:**

715: Panel cut-out 45 x 45 mm [1.772 x 1.772"]

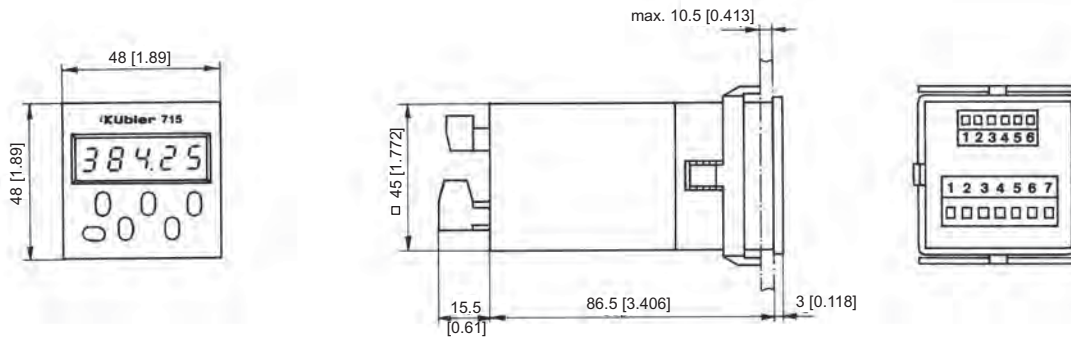

715: with front bezel 2  
Panel cut-out 50 x 50 mm [1.969 x 1.969"]

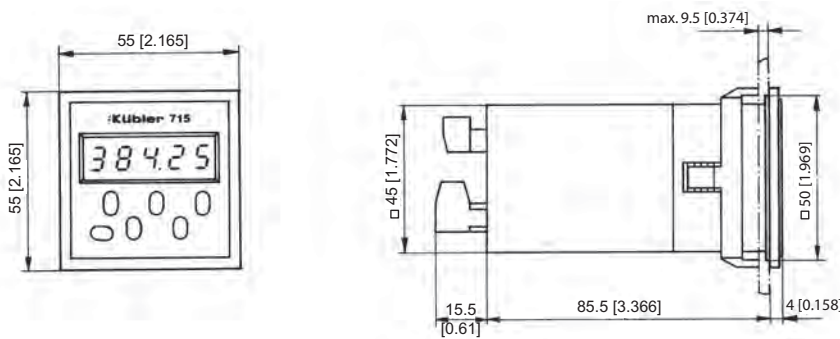

715: with front bezel 3  
Panel cut-out 50 x 50 mm [1.969 x 1.969"]

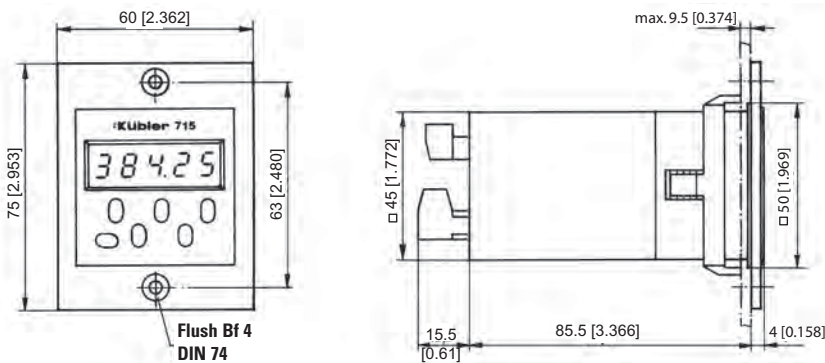

**Delivery specification:**

- Counter 715
- 1 Screw terminal plug 7 pin
- 1 Screw terminal plug 6 pin
- 1 Bezel for screw mount  
panel cut-out 50 x 50 mm [1.969 x 1.969"]
- 1 Bezel for clip mount  
panel cut-out 50 x 50 mm [1.969 x 1.969"]
- 1 Panel mounting clip
- 1 Panel cut-out template
- 1 Operating manual

**Order code**

6.715.01X.X00

Supply voltage  
0 = 230 V AC\*  
1 = 115 V AC\*  
3 = 11 ... 30 V DC\*

Output  
0 = Relay\*  
1 = Optocoupler

\* standard stock model

## Type 716/717 and 717 EX



### Your benefit

- Very bright 8 mm [0.315"] high display
- Programmable as a pulse counter, frequency meter or an operating time counter
- Wide range Power supply  
90 ... 260 V AC or  
10 ... 30 V DC
- approval
- -proof version

### Further product features

- Display range -199 999 ... 999 999 with zero blanking
- Easy to use and programmable with only 4 keys
- Option: serial interface  
RS 232, RS 422, RS 485
- Relay or optocoupler output
- Scaling factor 0.0001 ... 99.9999
- 716:** one preset
- 717:** two presets

### Technical data:

Supply voltage:	10 ... 30 V DC, max. 1.2 W with reverse polarity protection 90 ... 260 V AC, max. 5 VA	
Display:	6-digit 7-segment red LED; 8 mm [0.315"] high	
Counting inputs:	2 counting inputs, 4 types of programmable inputs	
Polarity of the inputs:	programmable, common for all inputs	
Input resistance:	approx. 10 k $\Omega$	
Counting frequency:	20 kHz, can be reduced to 30 Hz	
Minimum pulse duration for inputs:	5 ms	
Input switching level:	DC version: Low: 0 ... 0,2 x U <sub>B</sub> [V DC] High: 0,6 x U <sub>B</sub> ... 30 V DC AC version: Low 0 ... 4 V DC High 12 ... 30 V DC	
Pulse shape:	any shape (Schmitt-Trigger)	
Output 1 Relay:	with potential-free contacts, programmable as normally-closed (NC) or normally-open (NO) switching voltage max. 250 V AC/125 V DC, switching current max. 3 A. switching current min. at DC 30 mA switching power max. DC 90 W max. AC 750 VA	
or npn optocoupler:	with open collector and emitter switching power 30 V DC/15 mA	switching voltage max. 250 V AC/300 V DC, switching current max. 3 A. switching current at DC min. 30 mA switching power at DC 50 W at AC max. 2000 VA
Output 2 Relay:	with potential free switching contact, programmable opening or closing.	or npn-optocoupler: with open collector and emitter switching power 30 V DC/15 mA
		Accuracy: <0,1 % (at frequency meter mode) $\pm$ 50 ppm (at time counter mode)
		Output response time: Relay: approx. 7 ms Optocoupler: approx. 2 ms
		Data storage: min. 10 years or 10 <sup>8</sup> memory cycles
		Transmitter voltage: 24 V DC -40 %/+15 %, 100 mA at AC version
		Ambient temperature: -10 ... +50 °C [14 ... 122 °F]
		Storage temperature: -25 ... +70 °C [-13 ... 158 °F]
		EMC: according to EC EMC directive 89/36/EWG
		Emitted interference: EN 61 000-6-4/EN 55011 class B
		Immunity to interference: EN 61 000-6-2
		Protection: IP 65 front side EX-proof IP54
		Weight: approx. 200 g [7.055 oz] Ex-execution 2 kg [70.548 oz]
		only for EX proof: Counter in EX proof version acc. to explosion-proof class EEx D IIC T6, with encapsulated cable 2 x 3 m [2.188 x 3.281 yards] PTB approval no. Ex-96.D. 1024 hardcoated AL-housing function mode as type 717 Note: the EX-proof version has an additional fuse.

### Inputs:

#### 2 counting inputs

The maximum frequency is 20 kHz (20 kHz in the phase discriminator mode); it can be reduced to 30 Hz.

#### Gate

##### Static gate input

pulse count mode: no counting, when the input is active  
timer mode: Counting when active gate.lo or not activated gate.hi programmable

#### Reset

Dynamic reset input with the same function as the reset key. Resets the counter to zero, when counting up and sets it to the preset value when counting down

#### Key

Static key lock input. The keys are locked as long as this input is on. The preselection display key remains active

### Interfaces:

The devices can be fitted with the optional RS 232, RS422 or with the RS 485 interfaces. These interfaces can be used to program the devices as well as for remote reading. They are simply controlled by ESC sequences, max. 4800 Baud

### Programming:

The counters 716/717 are programmed by means of the 4 front keys. The operator guidance on this display allows a simple and intuitive programming. All settings can be carried out by selecting the corresponding parameters in this menu.

The follow modes can be programmed

1. Pulse counter
2. Frequency meter
3. Time meter

### Programmable are:

#### Input polarity:

Positive (pnp) or negative (npn). The selection is valid for all inputs.

#### Pulse or time counting modes:

- adding with counting; start at 0
- subtracting with counting start at the preset (716) and at preselection 2 (717)
- adding with automatic reset when the preset (716) or the preset 2 (717) is reached
- subtracting with automatic positioning at the preset (716) or preset 2 (717) when 0 is reached

#### Input types in pulse counter mode:

- Cnt.Dir 1 counting input  
1 counting direction input
- uP.dn Differential counting  
1 adding input  
1 subtracting input

- quad Phase discriminator to connect encoders with 2 signals shifted by 90°
- quad2 Phase discriminator with double pulse processing, to connect pulse sources with 2 signals shifted by 90°

#### Decimal places:

Data can be displayed with one, two or three decimal places

#### Factor:

For an optimum matching of the measuring signal, the displayed values can be weighted by a scale factor between 0.0001 and 99.9999.

#### Output signal:

The function of the output signal can be preselected (independently for both outputs of model 717) as a normally closed, normally open or a negative pulse signal.

#### Maximum counting frequency:

The maximum counting frequency can be set to 30 Hz or 20 kHz.

#### Timer:

Counting can be carried out in h, min, s or in h:min:s. The number of decimal places determines the resolution. A resolution up to the ms-range can be achieved.

### Connection diagram:

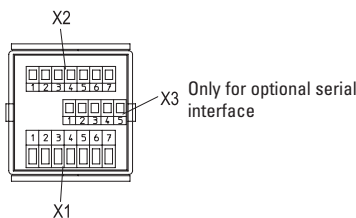

Pin connection X2:

Pin	Description	AC version	DC-Version
1	+24 V DC	Transmitter voltage	n.c.
2	0 V DC (GND)	GND	n.c.
3	INP A	Count input A	
4	INP B	Count input B	
5	Reset	Reset input	
6	Gate	Gate input	
7	Key	input for key lock	

Pin connection X1:

Pin	AC version	DC version
1	Output1 Relay Collector at Optocoupler output	
2	Output 1 Relay Emitter at Optocoupler output	
3	Output 2 Relay common contact (C) Emitter at Optocoupler output	
4	Output 2 Relay closing contact (NO)	
5	Output 2 Relay opening contact (NC) Collector at Optocoupler output	
6	Power supply 90 ... 250 V AC	10 ... 30 V DC
7	90 ... 250 V AC	0 V DC (GND)

Pin connection X3:

PIN No.	RS232	RS 422	RS 485
1	GND	—	—
2	RxD	RI+	DO/RI+
3	TxD	RI-	DO/RI-
4	RTS	DO+	—
5	CTS	DO-	—



- Easy parameter software for counter type 716/717 and process displays 55x.
- Upload and download function
- Monitor- and terminal program for easy diagnostic functions
- Online display of the measurement values
- German and English.

## Dimensions:

717

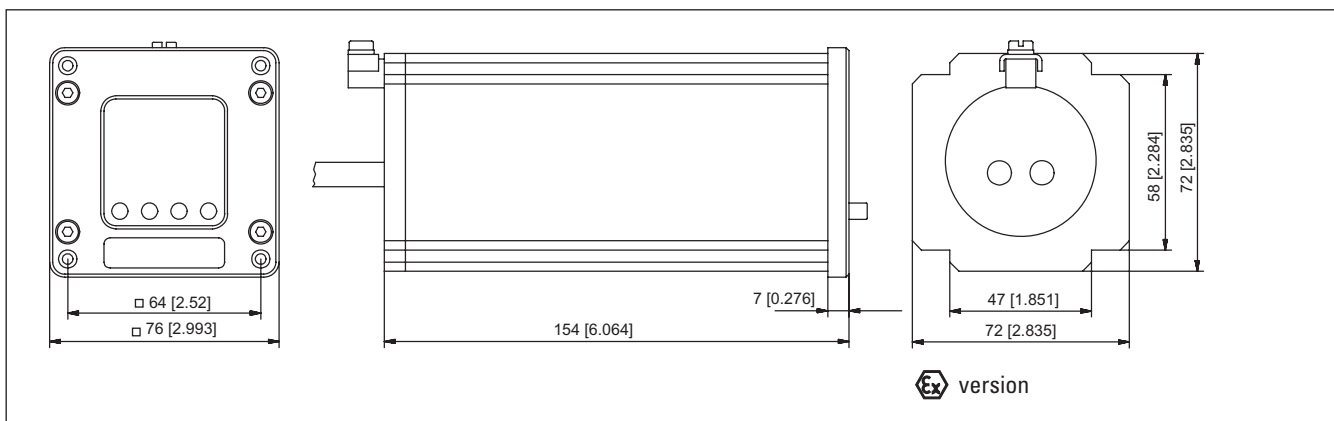
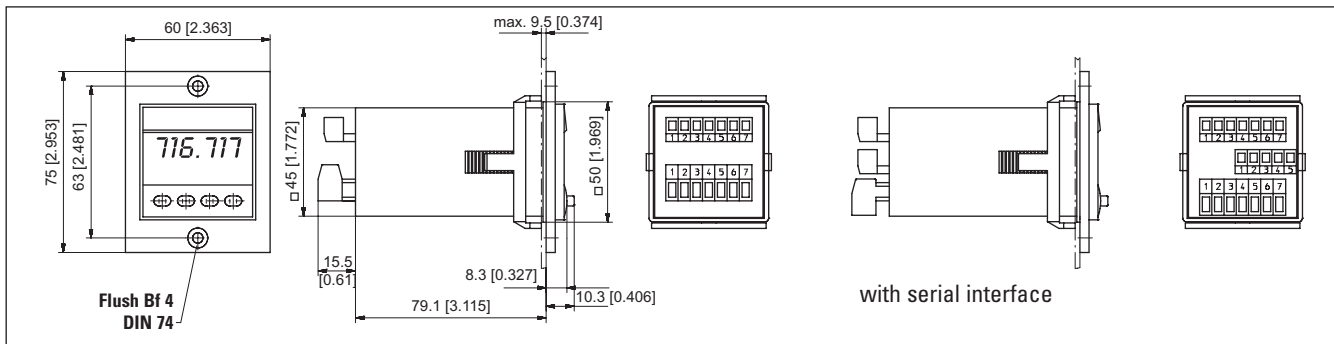
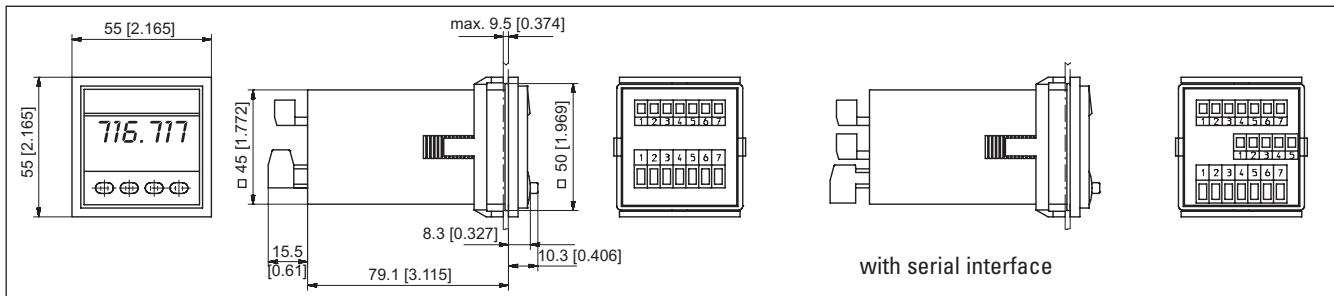
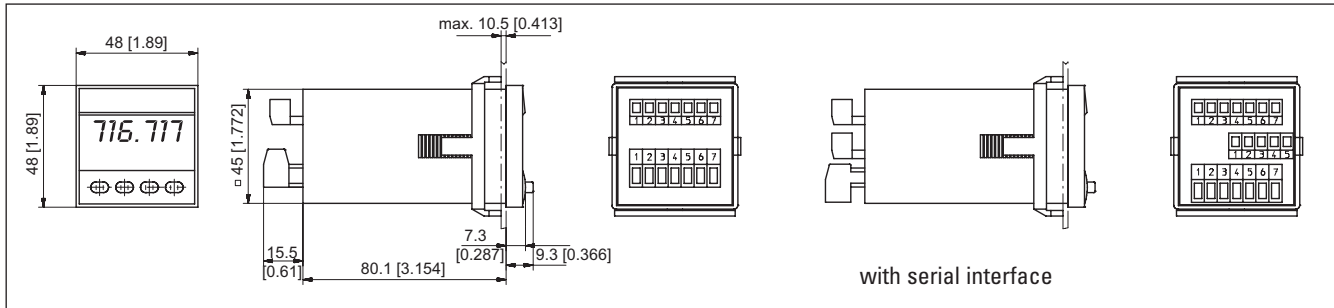

### Delivery specification: 716/717

- |   |  |
|---|--|
| Counter 716/717                           | 1 Bezel for clip mounting<br>panel cut-out 50 x 50 mm [1.969 x 1.969"] |
| 1 Screw terminal 7 poles, RM 5.08         |  |
| 1 Screw terminal 7 poles, RM 3.81         | 1 Mounting clip  |
| 1 Frame for screw mounting                | 1 Template for cut-out   |
| panel cut-out 50 x 50 mm [1.969 x 1.969"] | 1 Operating instructions   |

### Order code:

**6.71X.01X.XXX**

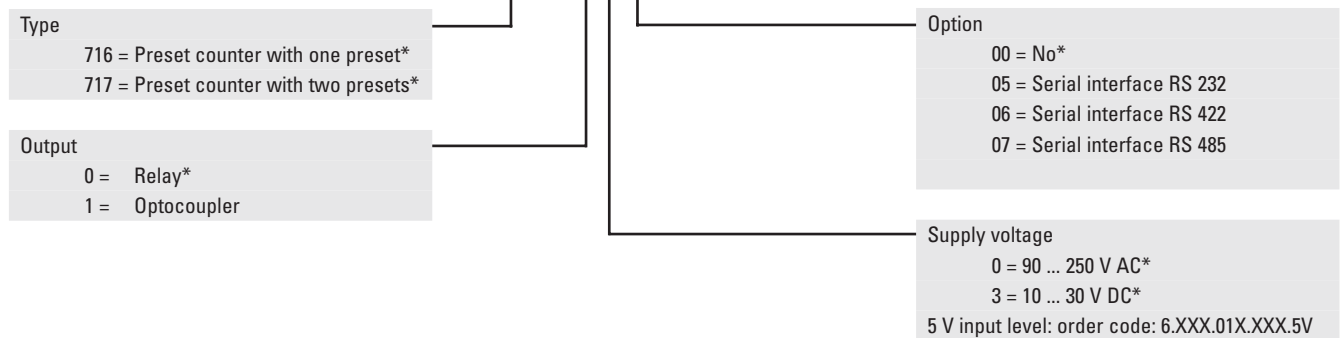

Preset counters

### Delivery specification: 717 Ex

Counter 717 in Ex-proof housing acc. to explosion-proof class EEx D IIC T6 with encapsulated cable 2 x 3 m [2.188 x 3.281 yards], various mounting parts, PTB approval certificate

\* standard stock model

### Order code for Ex proof version:

**6.717.010.X00.Ex**



## Display Type 571



### Your benefit

- AC and DC supply voltage in one unit
- Measuring function can be programmed for RPM, speed (from elapsed time), machine cycle time, throughput and baking time (time interval), as well as numerous count and stop-watch functions
- Scalable display, programmed via 2 keys
- Large 15 mm [0.591"] high LED-display, 6-digit, with adjustable brightness

### Product features

- Fast count input, works with our **LIMES** measuring system (100KHz)
- Version with 2 optocoupler outputs for alarms
- Version with analogue output, resolution 14 Bit: 0 ... 10 V, +10 V ... -10 V, 0 ... 20 mA, 4 ... 20 mA
- Version with serial interface RS232/485 for importing and exporting data
- 48 x 96 mm [1.89 x 3.78"] DIN housing, IP 65

### Technical data:

Supply voltage:	16 ... 35 V DC (Normal voltage: 24 V DC) 115/230 V AC $\pm$ 12,5 %
Display:	15 mm [0.591"] high LED-display, 6 digits
Current consumption [DC]:	18 V: 120 mA; 24 V: 95 mA; 30 V: 80 mA
Power consumption [AC]:	7.5 VA
Sensor power supply:	24 V DC $\pm$ 15%, 120 mA (at AC and DC supply)
<b>Inputs:</b>	3 Inputs (PNP, NPN and Namur) A, B = Impulse, C = Reset
Max. input frequency:	A, B = 25 kHz (100 kHz at count); C = 1 kHz
(Accuracy:	$\pm$ 1 ppm $\pm$ 1 digit
Input level HTL:	Low: 0 ... 3,5 V High: 9 ... 35 V

<b>Outputs:</b>	
Analogue-Output:	0 ... +10 V, 0 ... -10 V (0.571.012.E90) and 0 ... 20 mA, 4 ... 20mA
Resolution:	14 Bit + Sign
Accuracy:	0,1 %
Optocoupler-Output:	5 ... 35 V DC/150 mA (0.571.011.E00)
Interface	RS232 and RS485 acc. to ISO 1745 (0.571.012.E05) Drivecom Protocol
Operating temperature:	0 ... +45 °C [32 °F ... 113 °F]
Storage temperature:	-25 ... +70 °C [-13 °F ... 158 °F]
Protection:	IP 65 front side
EMC:	according to EC EMC directive 89/36/EWG
Interference emission:	EN 50081-2/EN 55011 class B
Interference resistance:	EN 6100-6-2
Weight:	approx. 200 g [7.055 oz]

### Dimensions:

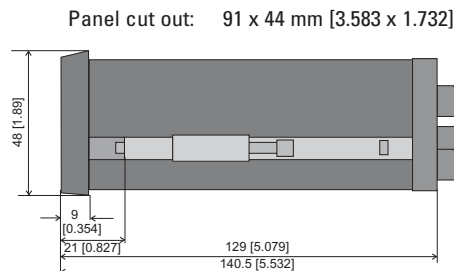
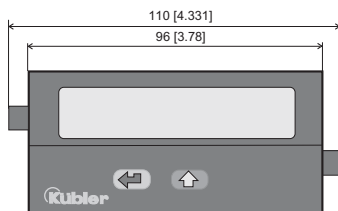

Display with serial interface (0.571.012.E05)

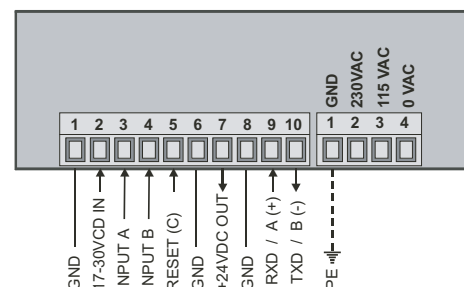

### Terminal assignment:

Display with analogue output (0.571.012.E90)

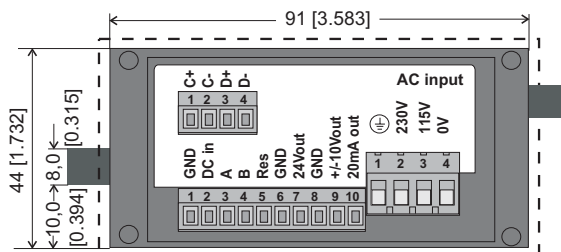

Display with 2 optocoupler outputs (0.571.011.E00)

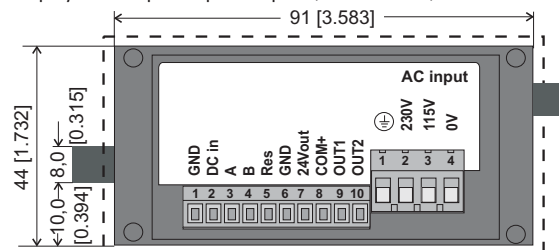

### Delivery specifications:

- Display 571
- Seal
- Mounting kit
- Plug-in screw terminals
- Manual German/English

### Order data:

- Display with 2 outputs Order code: 0.571.011.E00\*
- Display with analogue output Order code: 0.571.012.E90\*
- Display with ser. interface Order code: 0.571.012.E05



## Preset counter BVa 15



- 3- or 5-digit **adding** preset counter with stationary preset value
  - Preset value remains unchanged but can be adjusted at any time during the counting operation
  - 0-reset manual
  - Potential free changeover contact (micro-switch) on reaching the preset Contact remains switched till a 0-reset occurs
  - Contact is released in its position until 0-resetting
- Counter without front bezel fits into front frame F2B and may be combined in blocks of 50 x 50 mm [1.969 x 1.969"]
  - Can be combined with the counter series B-, MVs 36- and HVa.

### Applications:

piece-counting,  
automation

### Technical data:

Electrical connection:	Tin-plated tabs $\varnothing$ 1.6 mm [0.063"] with push-on connectors (counter) Tin plated tabs 0.8 x 2.8 mm [0.032 x 0.11"] (socket box)	Loading (max):	AC:	250 V AC, 2 A
Rated voltages:	Counting mechanism: 12/24/48/115 V DC $\pm$ 10 % 24/48/115/230 V AC $\pm$ 10 %		DC:	24 V DC, 2 A 60 V D, 0,7 A 115 V DC, 0,4 A 230 V DC, 0,2 A, with <b>resistive</b> Load.
Figures:	Counter 4.5 mm [0.177"], Preset 4 mm [0.158"]	Options:	Suitable spark quenching is required with <b>inductive</b> load, reducing the max. current to 60 %	
Colour of housing:	Black		Key locking 0-reset	
Colour of figures:	Counter: white on black Preset: yellow on black	Key locking transparent cover		
Shaft:	stainless steel	Counter with front plate size 3	Art. no.: 2.1X0.7XX.XXX	
Mounting position:	optional	Flexible sealing coverK2 (IP 54)		
Service life:	approx. 100 x 10 <sup>8</sup> Pulse	Counter with front frame no. 3	Art. no.: 2.1X0.6XX.XXX	
Weight:	approx. 130 g [4.586 oz]	Screw terminal		
Test voltage:	2 000 V, effective			
Switching contact:	1 change over contact (micro switch), release in 2nd half-step on the preset number			

### Type series:

Manual reset		Description
5-digit	3-digit	
BVa 15.01	BVa 15.01/3	no bezel frame
BVa 15.11	BVa 15.11/3	front bezel 1 with mounting holes
BVa 15.21	BVa 15.21/3	front frame 2 with spring clip
BVa 15.31	BVa 15.31/3	front bezel 3 with mounting holes

### Counting mechanism:

Voltage	Model	max. CP7s	Min. pulse-duration	Min. pulse-interval	Pulse-ratio	On time	Power consumption	Ripple voltage max.	Ambient temperature °C (non-condensing)
V DC	l	25/sec	24 ms	16 ms	3:2	100 %	3 W	48 %	-10 ... +60 °C [14 ... 140 °F]
V AC	a	18/sec	27.7 ms	27.7 ms	1:1	100 %	3 VA	-	-10 ... +55 °C [14 ... 131 °F]

### Connection diagrams:

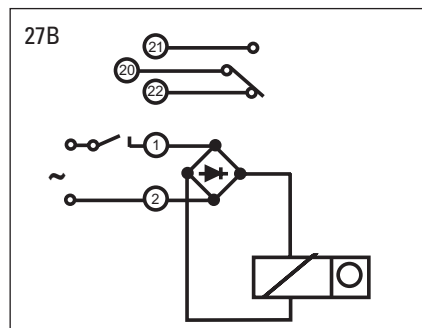
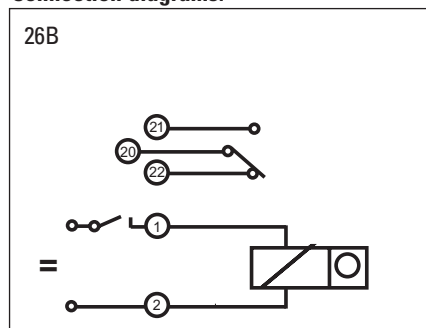

# Preset counter electromechanical



### Delivery specification:

Counter complete with push-on connectors

### Accessories:

- Socket box 946.1
- Sealing cover K2
- Front bezel F2B

### Order code:

- Art-No.
- If special voltages are requested, please state exact counter type, voltage and model e.g. BVa 15.31, 12 V DC....

## Type BVa 15.01

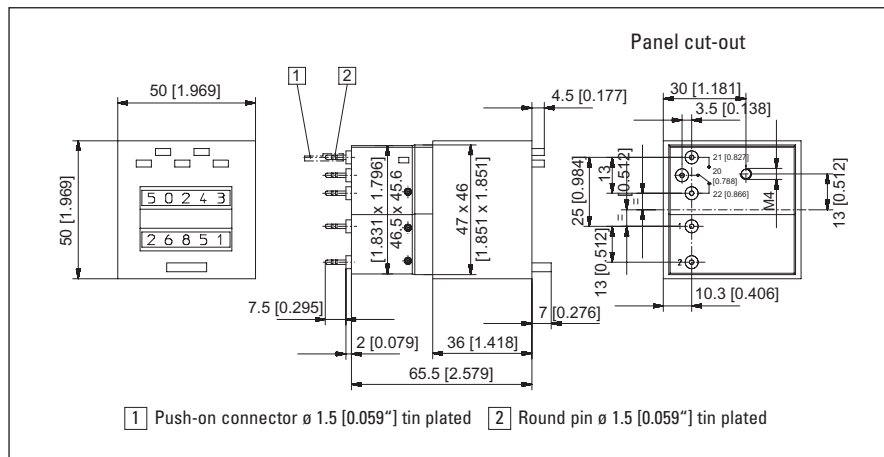

	BVa 15.01			BVa 15.01/3		
	24 V Art-No.	115 V Art-No.	230 V Art-No.	24 V Art-No.	115 V Art-No.	230 V Art-No.
DC (25 Imp/s)	2.100.011.033*	-	-	2.120.011.033		
AC (18 Imp/s)	2.100.011.061*	2.100.011.064	2.100.011.066	2.120.011.061	2.120.011.064	2.120.011.066

Colour of housing black:  
Art.-No. 2.1X0.011.XXX

## Type BVa 15.11

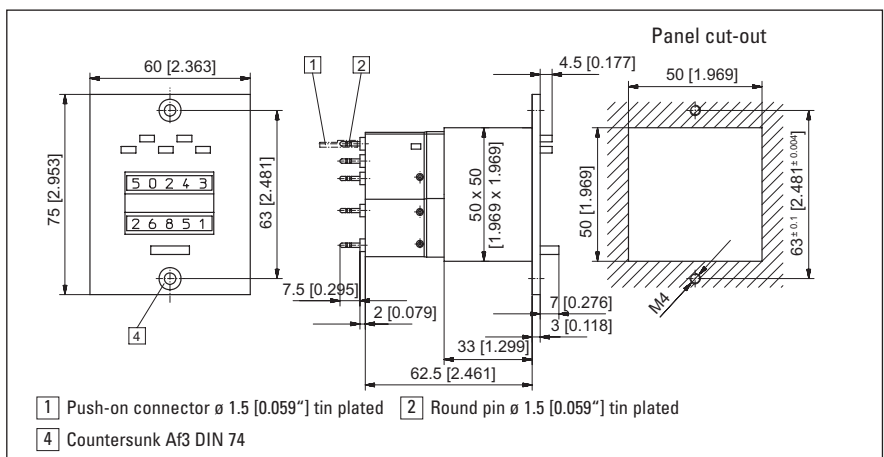

	BVa 15.11			BVa 15.11/3		
	24 V Art-No.	115 V Art-No.	230 V Art-No.	24 V Art-No.	115 V Art-No.	230 V Art-No.
DC (25 Imp/s)	2.100.110.033*	-	-	2.120.110.033		
AC (18 Imp/s)	2.100.110.061	2.100.110.064	2.100.110.066	2.120.110.061	2.120.110.064	2.120.110.066

Colour of housing black:  
Art.-No. 2.1X0.111.XXX

## Type BVa 15.21

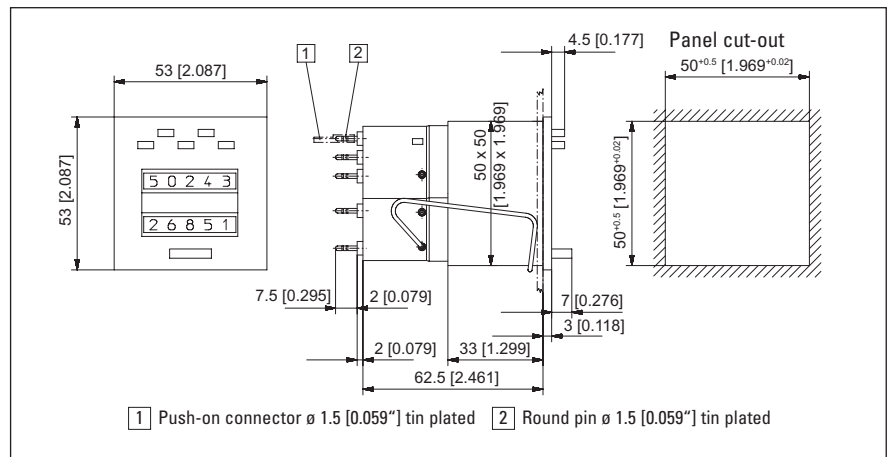

	BVa 15.21			BVa 15.21/3		
	24 V Art-No.	115 V Art-No.	230 V Art-No.	24 V Art-No.	115 V Art-No.	230 V Art-No.
DC (25 Imp/s)	2.100.210.033	—	—	2.120.012.033	—	—
AC (18 Imp/s)	2.100.210.061	2.100.210.064	2.100.210.066	2.120.210.061	2.120.210.064	2.120.210.066

Colour of housing  
black:  
Art-No. 2.1X0.211.XXX

## Type BVa 15.31

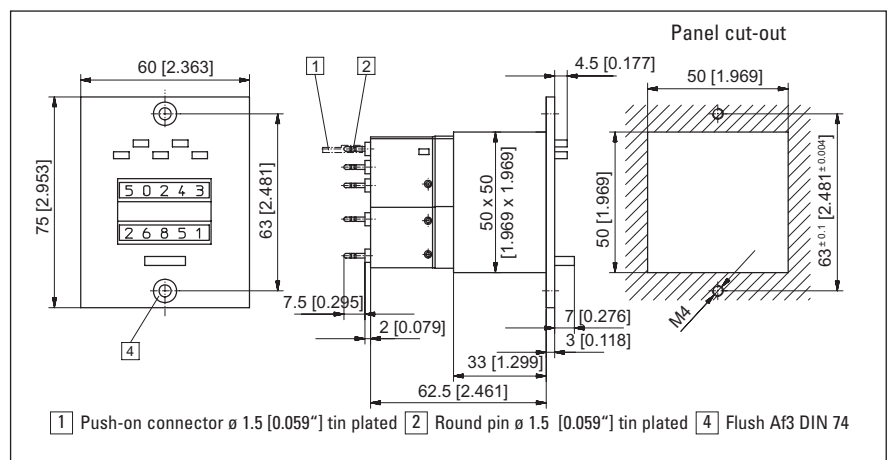

	BVa 15.31			BVa 15.31/3		
	24 V Art-No.	115 V Art-No.	230 V Art-No.	24 V Art-No.	115 V Art-No.	230 V Art-No.
DC (25 Imp/s)	2.100.310.033	—	—	2.120.110.033	—	—
AC (18 Imp/s)	2.100.310.061	2.100.310.064	2.100.310.066	2.120.310.061	2.120.310.064	2.120.310.066

Colour of housing  
black:  
Art-No. 2.1X0.311.XXX

### Options:

Key-locking 0-reset:

Colour of housing grey: Art-No. 2.1X0XX6.XXX

Colour of housing black: Art-No. 2.1X0.XX7.XXX

Knob-locking transparent cover (IP 55)

Counter with front bezel size 3

Art-No. 2.1X0.8XX.XXX

Flexible sealing cover K2 (IP 54)

Counter with front bezel size 3

Art-No. 2.1X0.6XX.XXX

**Preset counter BVa 15**



BVa 15.21 vs  
(Key lock)



Dv BVa 15.31  
(Knob locking cover )



Dvs BVa 15.31  
(Key locking cover)



Flexible cover K2

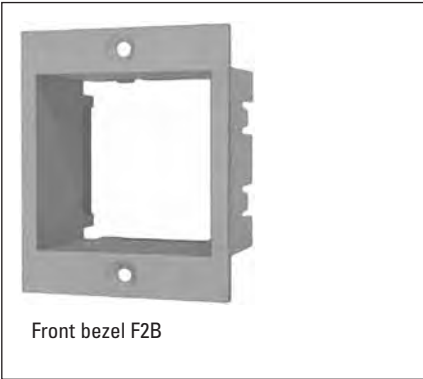

Front bezel F2B



Socket box 946.1  
G 008 439

For more details (dimensions, order information) please refer to our Accessories chapter

## Preset counter MVs 13



- Subtracting preset counter with 2 or 3 digits
- Manual or electrical reset
- Potential free change-over contact (micro switch)
- Contact remains in its position until resetting
- Delivery includes counter according to specifications and flat push-on connectors 2.8 mm [0.11"].

### Applications:

piece-counting,  
general event counting,  
automation etc.

### Technical data:

Electrical connection:	tin plated flat pins 0,8 x 2,8 mm [0.032 x 0.11"] with push on connectors
Rated voltages:	Count magnet: 12/24/48/115/230 V DC $\pm 10\%$ 24/48/115/230 V AC $\pm 10\%$
	Reset magnet: 24/48/115/230 V DC $\pm 10\%$ 24/48/115/230 V DC $\pm 10\%$
Figures height:	4 mm [0.158"]
Colour of housing:	grey, similar to RAL 7001
Colour of figures:	white on black background
Shaft:	stainless steel
Mounting position:	optional
Service life:	approx. $100 \times 10^6$ impulses
Weight:	with manual reset approx. 150 g [5.291 oz] with electrical reset approx. 190 g [6.702 oz]
Test voltage:	2 000 V, effective

Switching contact:	1 change over contact (micro switch), release in 2nd half-step on the preset number
Load (max):	AC: 250 V AC, 2A
	DC: 24 V DC, 2 A 60 V D. 0.7 A 115 V DC, 0.4 A 230 V DC, 0.2 A, at <b>resistive</b> load.
	at <b>inductive</b> : suitable spark quenching is required on inductive load, reducing the max. current to approx. 60 %
Options:	electrical reset only (on request)

### Type series:

3-digit		2-digit		Description
Reset manual	Reset man. and electr.	Reset manual	Reset man. and electr.	
MVs 13.11	MVs 13.13	MVs 13.11/2	MVs 13.13/2	Front panel with mounting holes
MVs 13.21	MVs 13.23	MVs 13.21/2	MVs 13.23/2	Front panel with spring clip

### Count mechanism:

Voltage	Model	Max. pulse-speed	Min.-pulse-on-time	Min.-pulse-interval	Pulse-ratio	On time approx.	Power consumption	Max. res. ripple	Ambient temperature °C*
V DC	1	25/sec	24 ms	16 ms	3:2	100 %	4 W	48 %	-10 ... +45 °C [14 ... 113 °F]
V AC	a	18/sec	22.2 ms	33.3 ms	2:3	100 %	4.5 VA	-	-10 ... +45 °C [14 ... 113 °F]

\*non-condensing

### Connection diagrams (manual reset):

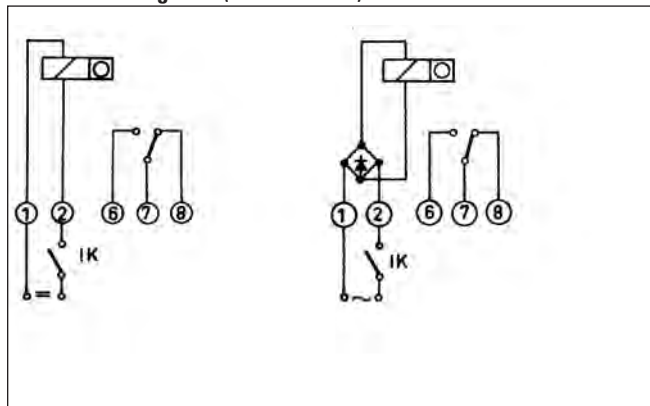

### Connection diagrams (electrical reset):

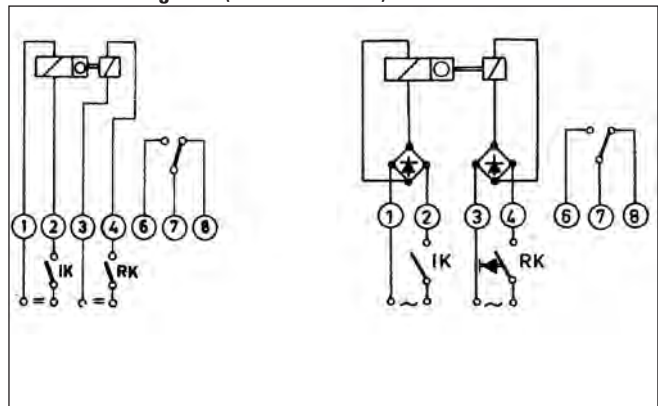

## Type MVs 13.11

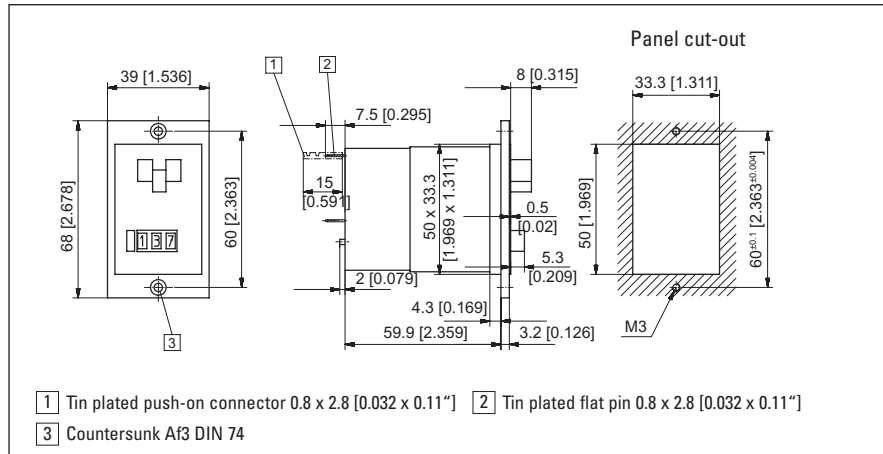

### Manual reset

	MVs 13.11(3-digit)			MVs 13.11/2 (2-digit)		
	24 V Art-No.	115 V Art-No.	230 V Art-No.	24 V Art-No.	115 V Art-No.	230 V Art-No.
DC (25 Imp/s)	2.300.110.033	—	—	2.310.110.033	—	—
AC (18 Imp/s)	2.300.110.061	2.300.110.064	2.300.110.066	2.310.110.061	2.310.110.064	2.310.110.066

## Type MVs 13.21

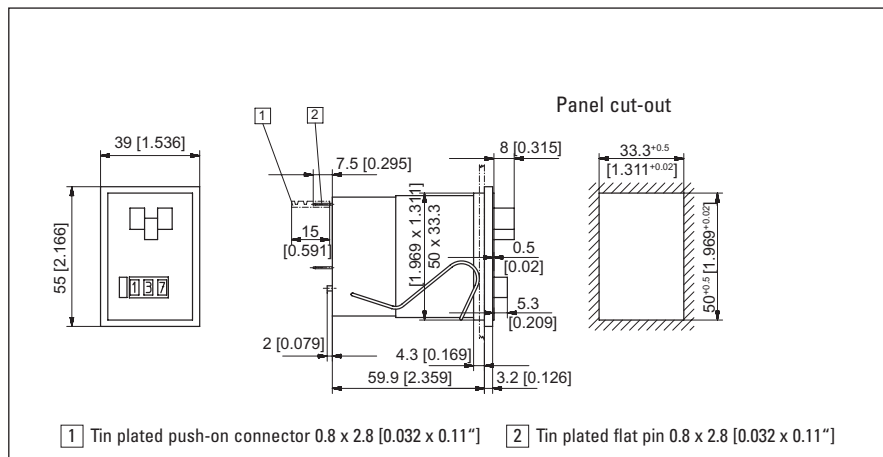

### Manual reset

	MVs 13.21 (3-digit)			MVs 13.21/2 (2-digit)		
	24 V Art-No.	115 V Art-No.	230 V Art-No.	24 V Art-No.	115 V Art-No.	230 V Art-No.
DC (25 Imp/s)	2.300.210.033	—	—	2.310.210.033	—	—
AC (18 Imp/s)	2.300.210.061	2.300.210.064	2.300.210.066	2.310.210.061	2.310.210.064	2.310.210.066

Colour of housing  
 black:  
 Art-No. 2.3X0.211.XXX

## Type MVs 13.13

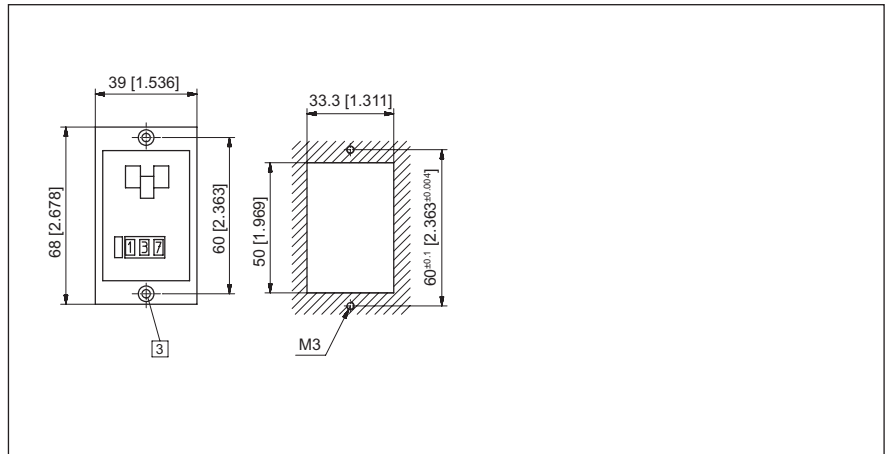

### Manual and electrical reset

	MVs 13.13 (3-digit)			MVs 13.13/2 (2-digit)		
	24 V Art-No.	115 V Art-No.	230 V Art-No.	24 V Art-No.	115 V Art-No.	230 V Art-No.
DC (25 Imp/s)	2.300.130.033	—	—	2.310.210.033		
AC (18 Imp/s)	2.300.130.061	2.300.130.064	2.300.130.066	2.310.130.061	2.310.130.064	2.310.130.066

## Type MVs 13.23

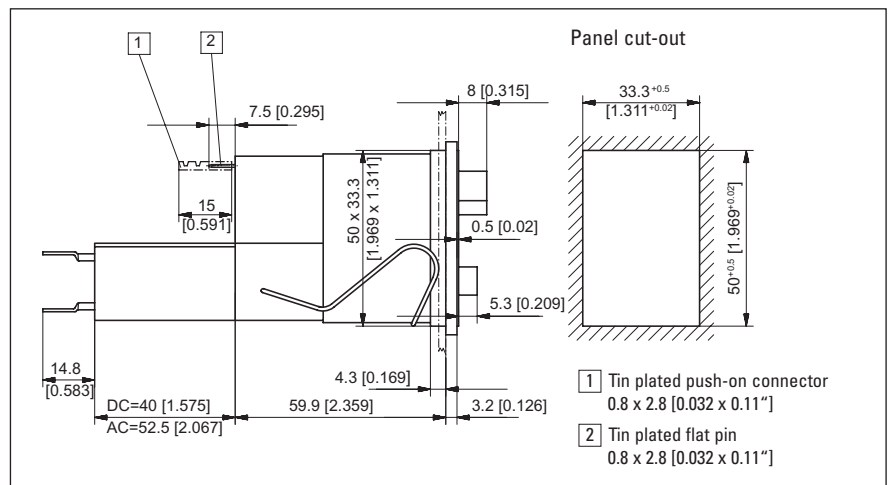

### Manual and electrical reset

	MVs 13.23 (3-digit)			MVs 13.23/2 (2-digit)		
	24 V Art-No.	115 V Art-No.	230 V Art-No.	24 V Art-No.	115 V Art-No.	230 V Art-No.
DC (25 Imp/s)	2.300.230.033	—	—	2.310.230.033		
AC (18 Imp/s)	2.300.230.061	2.300.030.064	2.300.230.066	2.310.230.061	2.310.230.064	2.310.230.066

## Preset counter MVs 16



- **Subtracting** preset counter with 3 or 6 digits
- Manual or manual and electrical reset
- Potential free charge over contact (micro switch) on reaching zero
- Contact remains in its position until resetting
- Delivery includes counter as ordered and flat push-on connectors

### Applications:

piece and batch counting, quantities automation processes etc.

### Technical data:

Electrical connection:	tin plated flat pins 0.8 x 2.8 mm [0.032 x 0.11"] with push-on connectors, tin plated flat tabs 0.8 x 2.8 mm [0.032 x 0.11"] (socket box)
Rated voltages:	counting magnet: 12/24/48/115 V DC $\pm 10\%$ 24/48/115/230 V AC $\pm 10\%$ reset magnet: 24/48/115 V DC $\pm 10\%$ 24/48/115/230 V DC $\pm 10\%$
Figures:	4 mm [0.158"]
Colour of housing:	grey, similar to RAL 7001
Colour of figures:	white on black
Shaft:	stainless steel
Mounting position:	optional
Service life:	approx. $100 \times 10^6$ pulses
Weight:	with manual reset: approx. 170 g [5.997 oz] with electrical reset: approx. 210 g [7.408 oz]

Test voltage:	2 000 V AC, effective
Switching contact:	1 change over contact (micro switch), contact making in 2nd half step at zero
Load (max):	AC: 250 V AC, 2 A DC: 24 V DC, 2 A 60 V D. 0.7 A 115 V DC, 0.4 A 230 V DC, 0.2 A, at <b>resistive</b> load. at <b>inductive</b> load: suitable spark quenching is required on inductive load, reducing the max. current to approx. 60 %

### Type series:

6-digit		Description
reset	reset	
manual	man. and electr.	no front bezel, plug-in socket
–	MVs 16.03	
MVs 16.11	–	front bezel 1 with mounting holes
MVs 16.21	MVs 16.23	front bezel 2 with spring clip

### Options:

Locking transparent cover (IP 55) counter with front bezel 3 3  
Art-No. 2.1X0.7XX.XXX  
Transparent locking cover (IP 55)  
Counter with front bezel 3  
Art-No. 2.1X0.8XX.XXX  
Flexible sealing cover K2 (IP 54) counter with front bezel size 3  
Art-No. 2.1X0.6XX.XXX

### Accessories:

Socket box 926.1 Art-No. G.008.443  
Sealing cover  
K2 grey: Art-No. G.008.302  
K2 black: Art-No. G.008.303  
Front bezel  
F2M grey Art-No. T.008.105  
Delivery includes flat pin connectors

### Count mechanism:

Voltage	Model	Max. impulse-speed	Min. pulse-on-time	Min. pulse-interval	pulse-ratio	On time	Power consumption	Max. res ripple	Ambient temperature °C
V DC	I	25/sec	24 ms	16 ms	3:2	100 %	4 W	48 %	–10 ... +45 °C [14 ... 113 °F]
V AC	a	18/sec	22.2 ms	33.3 ms	2:3	100 %	4.5 VA	–	–10 ... +45 °C [14 ... 113 °F]

### Connection diagram (manual reset):

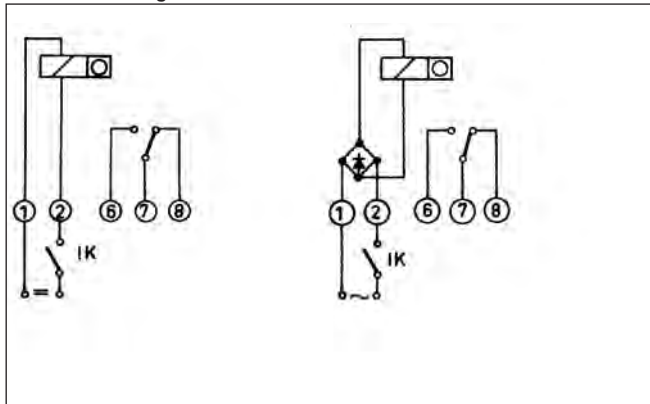

### Connection diagram (electrical reset):

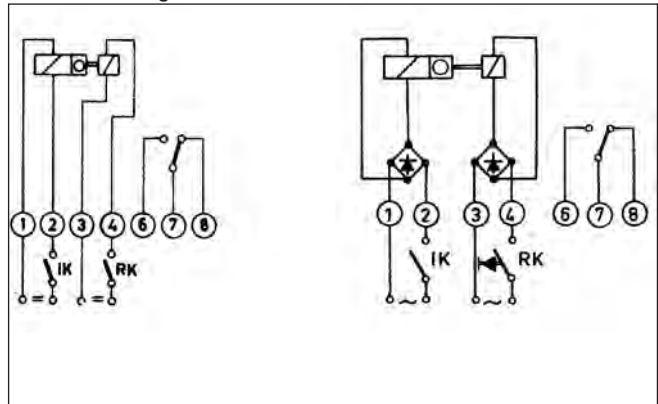



## Type MVs 16.11

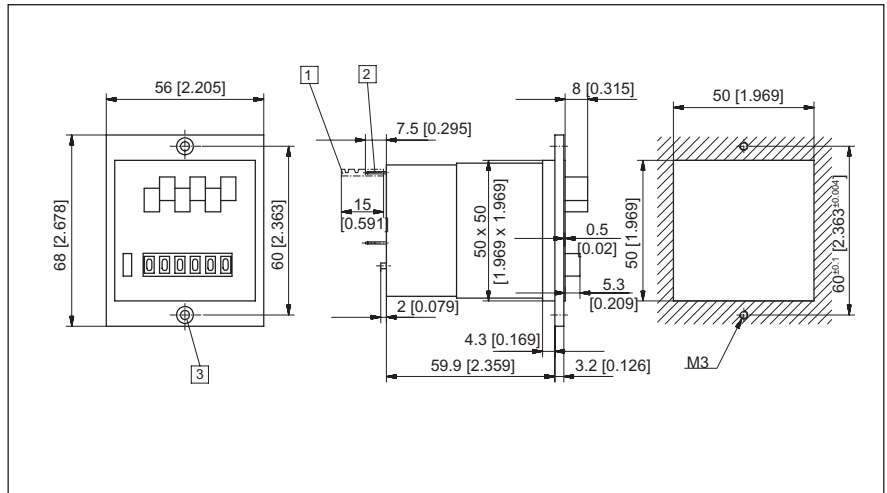

### Manual reset

	MVs 16.11 (6-digit)		
	24 V Art-No.	115 V Art-No.	230 V Art-No.
DC (25 Imp/s)	2.320.110.033	—	—
AC (18 Imp/s)	2.320.110.061	2.320.110.064	2.320.110.066

- 1 Tin plated push-on connector 0.8 x 2.8 [0.032 x 0.11"]
- 2 Tin plated flat pin 0.8 x 2.8 [0.032 x 0.11"]
- 3 Countersunk Af3 DIN 74

Preset counters

## Type MVs 16.21

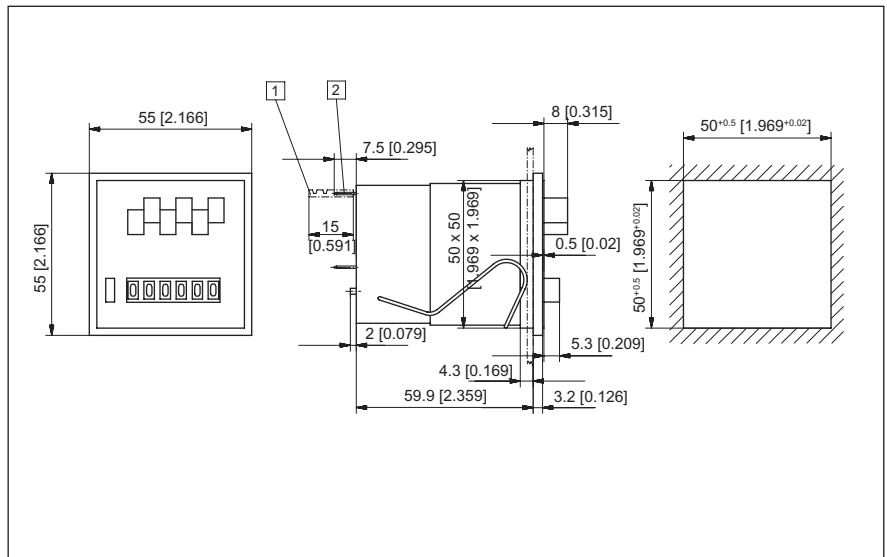

### Manual reset

	MVs 16.21 (6-digit)		
	24 V Art-No.	115 V Art-No.	230 V Art-No.
DC (25 Imp/s)	2.320.210.033	—	—
AC (18 Imp/s)	2.320.210.061	2.320.210.064	2.320.210.066

- 1 Tin plated push-on connector 0.8 x 2.8 [0.032 x 0.11"]
- 2 Tin plated flat pin 0.8 x 2.8 [0.032 x 0.11"]

## Type MVs 16.03

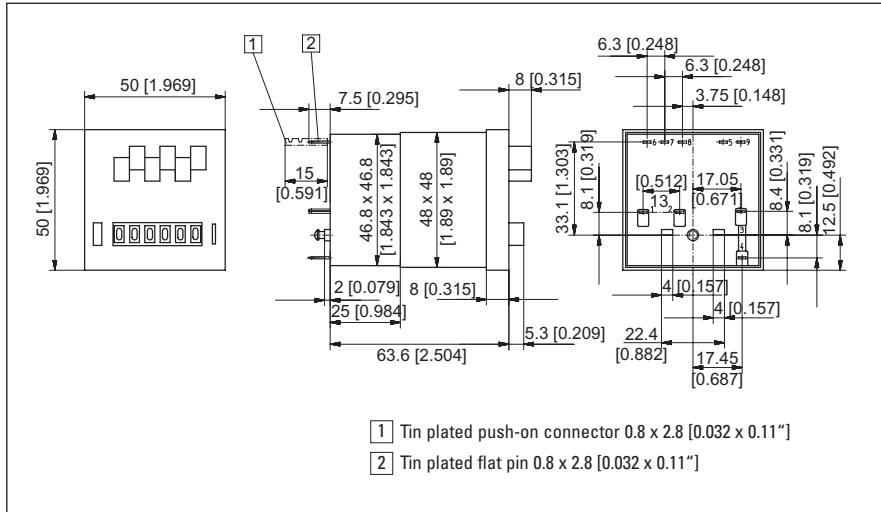

### Manual and electrical reset

	MVs 16.03 (6-digit)		
	24 V Art-No.	115 V Art-No.	230 V Art-No.
DC (25 Imp/s)	2.320.030.033	—	—
AC (18 Imp/s)	2.320.030.061	2.320.030.064	2.320.030.066

## Type MVs 16.23

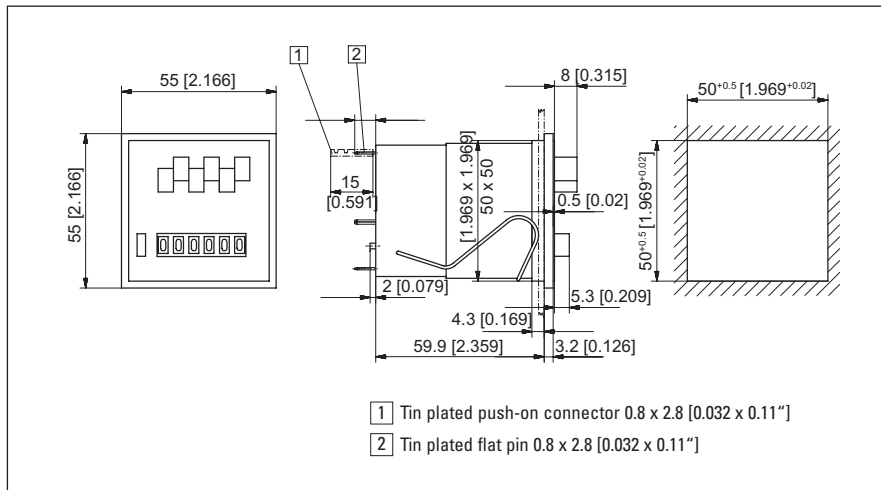

### Manual and electrical reset

	MVs 16.23 (6-digit)		
	24 V Art-No.	115 V Art-No.	230 V Art-No.
DC (25 Imp/s)	2.320.230.033	—	—
AC (18 Imp/s)	2.320.230.061	2.320.230.064	2.320.230.066

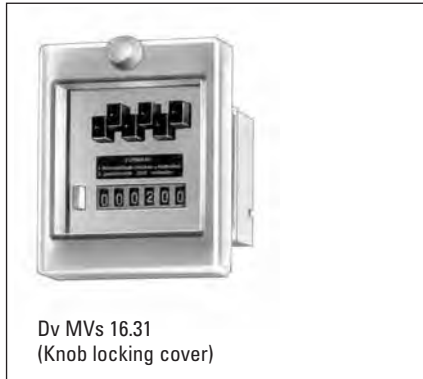

For more details, please refer to our Accessories chapter



**Table of Contents**

Type of counters	Series	Display	Panel cut-out W x H [mm]	without	Reset man.	electr.	Remarks	Page	
<b>Timers electromechanical</b>	Micro timers	HK 46	9999.99 h	27 x 14	•	–	–	Panel or PCB mount high shock resistance, small power consumption	158
		HK 47	99999.99 h	27 x 14	•	–	–		158
		HK 07/AHK 07	99999.99 h	30 x 13	•	–	–	Panel or PCB mount, high shock resistance	159
		HK 07 D	99999.9 h	30 x 13	•	–	–		163
		SHK 07.1	99999.99 h	–	•	–	–	for DIN rail mount	165
	Standard timers	HK 17	999999.99 h	33 x 22	•	–	–	Panel mount, small size	166
		H 37	999999.99 h	e. g. 45 x 22	•	–	–		170
		H 37 S	999999.99 h	e. g. 45 x 22	•	–	–		173
		H 57	999999.99 h	45 x 45	•	–	–	Panel mount	175
		H 57 S	999999.99 h	45 x 45	•	–	–		177
		AH 57	999999.99	–	•	–	–	for DIN rail mount	176
		HR 76	99999.9 h	∅ 50,8	•	–	–	Panel mount, low cost	179
		HB 26	9999.99 h	50 x 25	–	•	–	Panel mount	180
		HB 27	99999.99 h	50 x 25	•	–	–		183
	SH 17	99999.9 h	–	•	–	–	for DIN rail mount	185	
	Counter with double function	HC 77	999999.99 h	45 x 45/∅ 50.8	•	–	–	Panel mount for time and pulses	186
		SHC 77	999999.99 h	–	•	–	–	DIN rail mount for time and pulses	188
		HW 66	999999 h	45 x 45/∅ 50.8	•	–	–	Panel mount for time and kWh	189
<b>Timers electronic</b>	LCD	Codix 134	99999-99 h	45 x 22	–	•	•	Panel mount, battery powered	190
		Codix 135	9999999.9 s	45 x 22	–	•	•		192
	LCD Module	194	9999-99 h	–	–	–	•	PCB mount	194
		198	99999.9 h	–	–	–	•		195
	LED	Codix 523	999999	45 x 22	–	•	•	Panel mount, timer	196
		Codix 524	999999	45 x 22	–	•	•	Panel mount, multifunction	198
		Codix 52U	999999	45 x 22	–	•	•	Panel mount, universal with dual functions	200
		Codix 543	999999	92 x 45	–	•	•	Panel mount, timer	202
		Codix 544	999999	92 x 45	–	•	•	Panel mount, multifunction	204
		Codix 54U	999999	92 x 45	–	•	•	Panel mount, universal with dual functions	206
<b>Preset timer electronic</b>	LCD	923/924	999999	45 x 45	–	•	•	Panel mount, AC or DC-supply with options	208
		903/904	999999	45 x 45	–	•	•	Panel mount, AC or DC-supply	214
	LED	715	99999	45 x 45	–	•	•	Panel mount, AC or DC-supply	217
		Codix 716/717	999999	45 x 45	–	•	•	Panel mount, also with Ex or interface	220
		571	999999	92 x 45	–	•	•	Panel mount, multifunction	224
<b>Preset timer</b>		HVa 15	9999.9 h	50 x 50	–	•	–	Panel mount	225
<b>Time relay</b>	910	99999	45 x 45	–	•	•	Panel mount, time relay	228	

## Micro Hour Meters HK 46/HK 47



- 6- or 7-digit micro hour meters; displays 1/100 h
- Low cost
- High shock resistance
- Low power consumption; suitable for battery operation
- Small dimensions
- Magnified large figures
- Flush mount with integrated spring clip (snap in) (HK 47.20)
- PCB-mount (HK 47.80)

- Solderable and wash proof (HK 47.80)
- Protection to IP 66
- Long service life

### Applications:

time registration, maintenance intervals for measuring instruments (respiration units, oxygen, dialysis), UV-lamps, machines panel indicators in vehicles ...

### Technical data:

Drive:	Quartz controlled impulse counter
Impulse duration:	32 ms; every 36 s = 0.01 h (Power on times < 36 s are not counted)
Electrical connection:	HK 46.20/HK 47.20: Flying leads AWG 22, approx. 150 mm [5.906"] long (red +, black -) HK 46.80/HK 47.80: solder pins $\varnothing$ 0.64 mm [0.025"]
Display:	9999.99 h resp. 99999.99 h
Figures:	white on black 1/10, 1/100 decimal red on black
Supply voltage:	4.5 ... 35 V DC
Residual ripple:	< 1 %
Current consumption:	< 1,5 mA (average)
Power consumption:	at $U_B = 5$ V DC typ. 82 mW at $U_B = 12$ V DC typ. 135 mW at $U_B = 24$ V DC typ. 135 mW max. 170 mW (count impulse every 36 s with an impulse duration of 32 ms)
Accuracy:	22.5 ppm at 20 °C [68 °F]

Height of figures:	HK 47: 4 x 1.25 mm [0.158 x 0.049"] HK 46: 4 x 1.7 mm [0.158 x 0.067"] magnified
Reset:	no reset
Ambient temperature:	-10 ... +60 °C [14 .. 140 °F]
Storage temperature:	-20 ... +70 °C [-4 ... 158 °F]
Soldering temperature:	max. 265 °C, max. 3 sec.
Mounting position:	number of wheel view horizontal (other on request)
Solderable and wash proof versions:	HK 46.80/HK 47.80
Protection according to EN 60529:	IP 66 at HK 46.80/HK 47.80 IP 66 (only front) at HK 46.20/HK 47.20
Conforms to CE:	EN 61000-6-2
Requirements acc. to:	EN 55011 class B
Housing:	PC transparent; HK 47.80
Weight:	13 ... 15 g [0.459 ... 0.529 oz]
Options for:	
HK 4X.20, 4X.80:	flat pin 0.8 x 2.8 mm [0.032 x 0.11"] and push-on connectors
HK 46.20/HK 47.20:	solder pins $\varnothing$ 0.64 mm [0.025"]

### Dimensions:

#### HK 46.20/HK 47.20

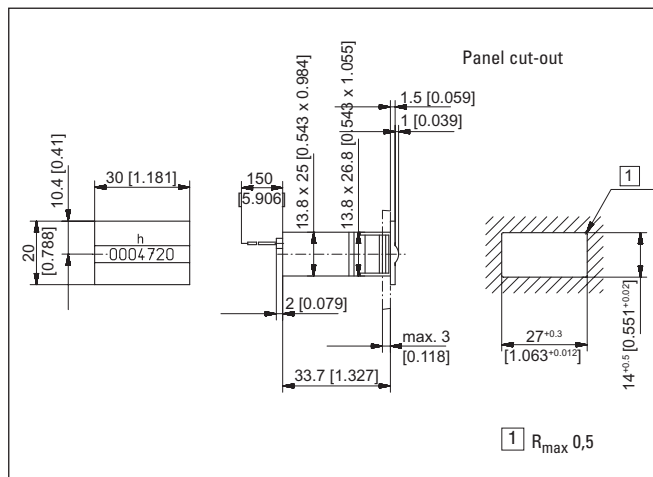

#### HK 46.80/HK 47.80

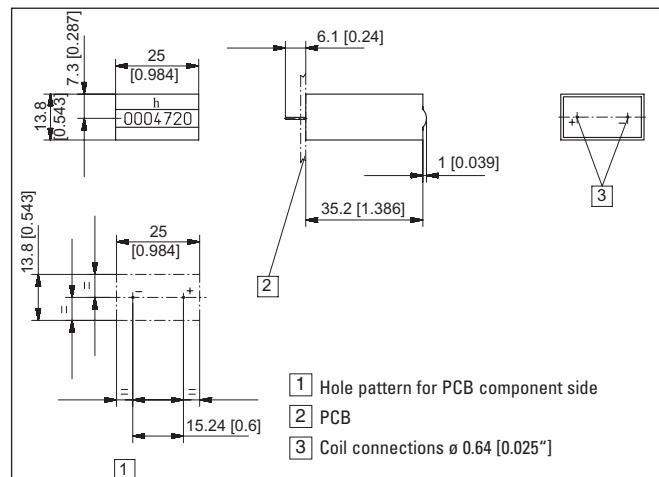

### Order code:

	HK 46.20	HK 47.20
	Art. no.	Art. no.
4.5 ... 35 V DC	3.050.200.383	3.060.200.383 *

	HK 46.80	HK 47.80
	Art. no.	Art. no.
4.5 ... 35 V DC	3.050.800.383	3.060.800.383

\*standard stock model

## Micro Hour meter HK 07



- 7-digit micro hour meter
- **High shock resistance**
- Low power consumption allows battery operation
- Small size
- Magnified figures
- Built in counter
- PCB mount counter
- Solderable and wash proof version
- Protection IP 65
- Wide voltage range 4.5 ... 35 V DC
- Data retention if power is lost
- long life time service

### Applications:

general counting, service interval for measurement systems (respiratory ventilators, oxygen machines, dialysis machines), small appliances, UV lamps, display panels in cars.

### Technical data:

Electrical connection:	base mount models: Flying leads approx. 150 mm [5.906"] (red +, black -) PCB mount models: tin plated solder pins 0.4 x 1.2 mm [0.016 x 0.047"]	Height of figures:	1.35 x 2.8 mm [0.053 x 0.11"]
Typ. power consumption:	at $U_B = 5$ V DC approx. 82 mW at $U_B = 12$ V DC approx. 135 mW at $U_B = 24$ V DC approx. 135 mW max. 170 mW (every 36 s with a pulse length of 32 ms)	Colour of figures:	white and red on black
Rated voltages:	4.5 ... 35 V DC	Reset:	no
Residual ripple:	< 1 %	Ambient temperature:	-10 ... +60 °C [14 ... 140 °F]
Current consumption:	< 1.5 mA (average)	Soldering temperature:	max. 265 °C, max. 3 sec.
On time:	100 %	Mounting position:	number of wheel view horizontal (other on request)
Display:	7 figures (99999.99 h)	Solderable and wash proof versions:	HK 07.90, HK 07.91, HK 07.92
Accuracy:	22.5 ppm at 20 °C [68 °F]	Protection:	up to IP 65 depending on kind of type
Count mode:	adding	Conforms to ce:	EN 61000-6-2
		Requirements acc. to:	EN 55011 class B
		Housing:	Plastic
		Weight:	12 ... 14 g [0.423 ... 0.494 oz]
		Options:	
		HK 07.20	Flat pins 0.3 mm x 2.8 mm [0.012 x 0.11"]
		Further options:	Temperature range -30 ... +85 °C [-22 ... 185 °F] -20 ... +70 °C [-4 ... 158 °F]

### Available types:

Type	Housing	Height of figures	display	Termination	Description
HK 07.20	Plastic	4 mm [0.158"]	On narrow side	Flying leads	Flush mount with click stop device
HK 07.40	Steel sheet	4 mm [0.158"]	On broad side	Solder pins	PCB-mount
HK 07.50	Steel sheet	4 mm [0.158"]	On narrow side	Solder pins	PCB-mount
HK 07.80	Plastic	4 mm [0.158"]	On narrow side	Solder pins	PCB-mount
HK 07.90	Plastic	4 mm [0.158"]	On broad side	Solder pins	PCB-mount wash proof
HK 07.91	Plastic	2,8 mm [0.11"]	On narrow side	Solder pins	PCB-mount wash proof
HK 07.92	Plastic	4 mm [0.158"]	On narrow side	Solder pins	PCB-mount wash proof
AHK 07.00	Plastic	4 mm [0.158"]	On narrow side	Flying leads	Base mount

### Type HK 07.20

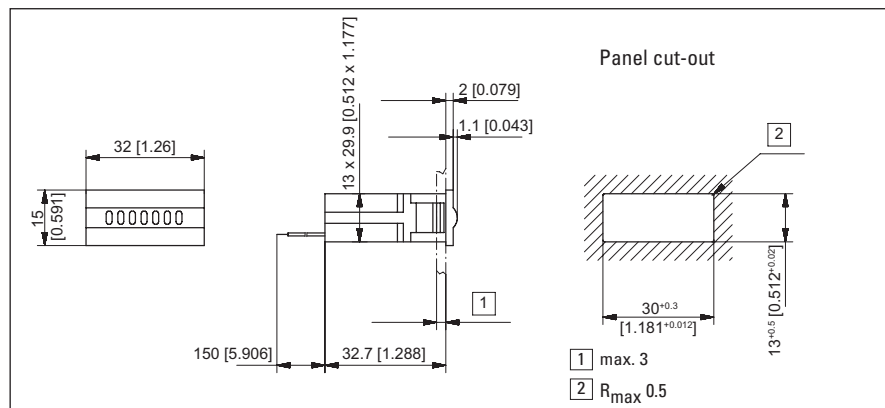

### Order code:

Art-No.	4.5 ... 35 V	3.100.200.383*
---------	--------------	----------------

\*standard stock model  
Further standard stock models:  
3.107.200.383 HK 07.20.35 4.5 ... 35 V DC with flat pin

# Time meter



## Type HK 07.50

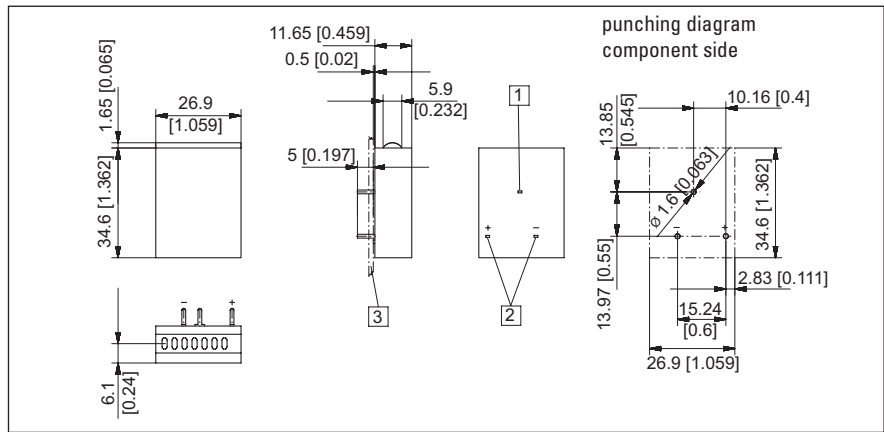

HK 07.50	4.5 ... 35 V DC	
Art-No.	3.100.501.383	

- 1 Potential free mounting pin 0.4 x 1.2 [0.016 x 0.047"]
- 2 Coil connections 0.4 x 1.2 [0.016 x 0.047"]
- 3 PCB

## Type HK 07.40

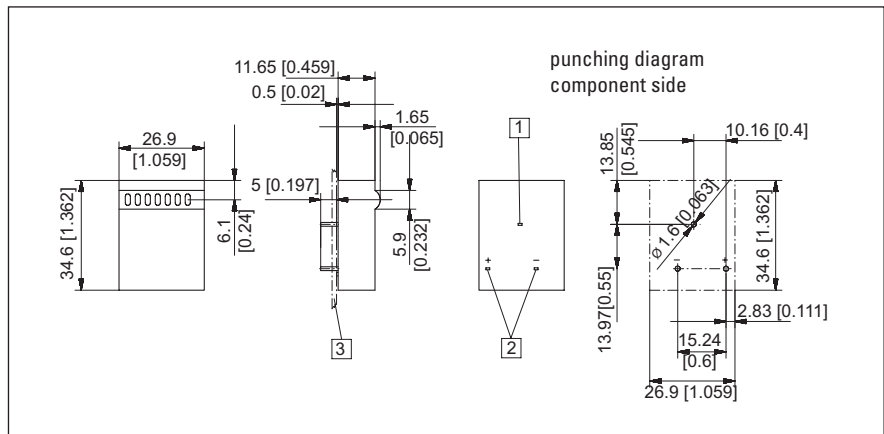

HK 07.40	4.5 ... 35 V DC	
Art-No.	3.100.401.383	

- 1 Pins without el. function 0.4 x 1.2 mm [0.016 x 0.047"]
- 2 Coil connections 0.4 x 1.2 mm [0.016 x 0.047"]
- 3 PCB

## Type HK 07.91

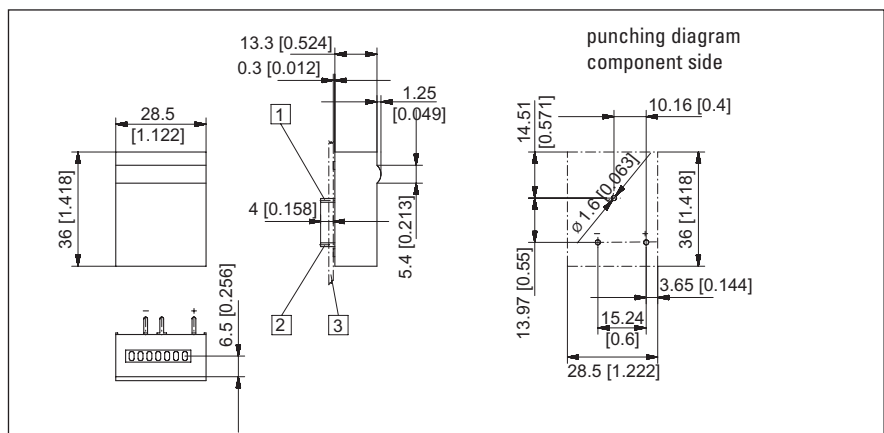

HK 07.91	4.5 ... 35 V	
Art-No.	3.100.910.383	

- 1 Potential free mounting pin 0.4 x 1.2 mm [0.016 x 0.047"]
- 2 Coil connections  $\varnothing$  0.64 0.4 x 1.2 mm [0.025 x 0.047"]
- 3 PCB



## Type HK 07.92

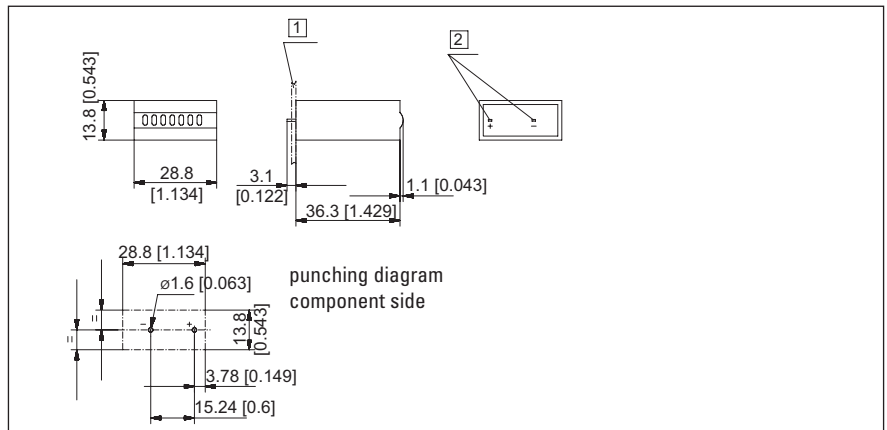

HK 07.92	4.5 ... 35 V	
Art-No.	3.100.920.383	

- 1 Potential free mounting pin 0.4 x 1.2 mm [0.016 x 0.047"]
- 2 Coil connections 0.4 x 1.2 mm [0.016 x 0.047"]

## Type HK 07.90

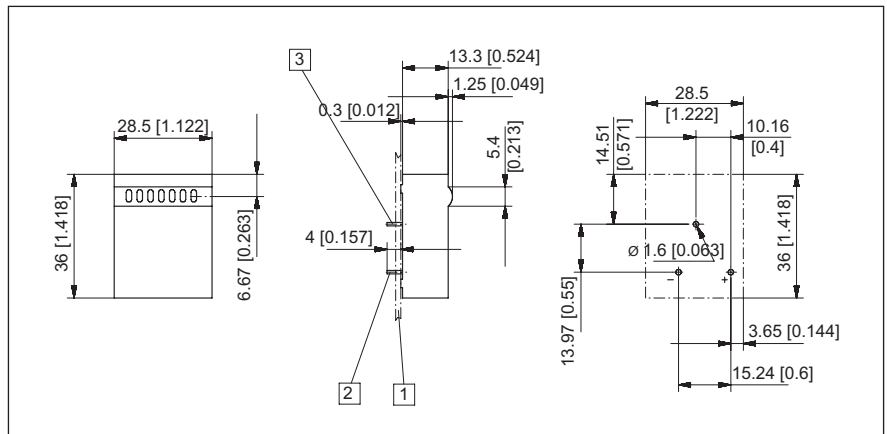

HK 07.90	4.5 ... 35 V	
Art-No.	3.100.900.383	

- 1 Potential free mounting pin 0.4 x 1.2 mm [0.016 x 0.047"]
- 2 Coil connections 0.4 x 1.2 mm [0.016 x 0.047"]
- 3 PCB

## Type AHK 07.00

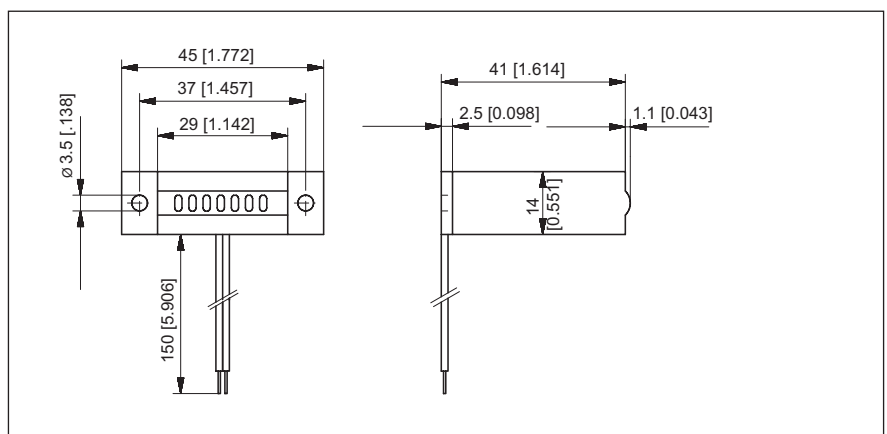

AHK 07.00	4.5 ... 35 V	
Art-No.	3.100.000.393	

## Type HK 07.80

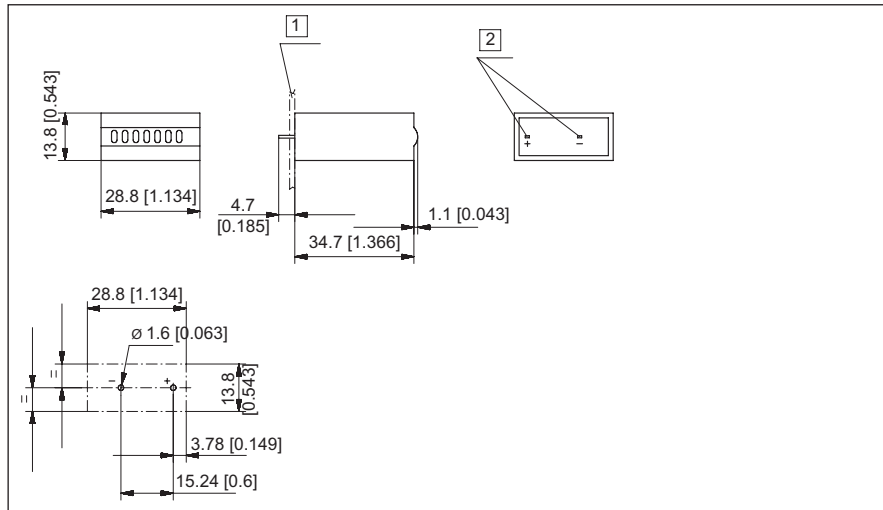

HK 07.80	4.5 ... 35 V	
Art-No.	3.100.800.383	

- 1 Potential free mounting pin 0.4 x 1.2 mm [0.016 x 0.047"]
- 2 Coil connections 0.4 x 1.2 mm [0.016 x 0.047"]

## Micro Hour Meters HK 07, Disable-Input



- Disable-Input: also allows registration of short on-times (<36 s). They are stored in the integrated circuit.
- 7 digits
- **High shock resistance**
- Low power consumption allows battery operation
- Magnified figures
- Built in counter
- PCB mount counter
- Solderable and wash proof version

### Applications:

general counting, service interval for measurement systems (respiratory ventilators, oxygen machines, dialysis machines), small appliances, UV lamps, display panels in cars.

### Technical data:

Electrical connection:	Base mount models: Flying leads approx. 150 mm [5.906"]	Height of figures:	1.35 x 2.8 mm [0.053 x 0.11"]
	PCB-mount: tin plated solder pins size 0.4 x 1.2 mm [0.016 x 0.047"]	Colour of figures:	white and red on black
		Reset:	no
Typ. power consumption:	at $U_B = 5\text{ V DC}$ typ. 82 mW	Ambient temperature:	-10 ... +60 °C [14 ... 140 °F]
	at $U_B = 12\text{ V DC}$ typ. 135 mW	Soldering temperature:	max. 265 °C, max. 3 sec.
	at $U_B = 24\text{ V DC}$ typ. 135 mW	Mounting position:	number of wheel view horizontal (other on request)
	max. 170 mW	Solder- and wash proof versions:	HK 07.90D and HK 07.91D,
	(every 36 s with a pulse length of 32 ms)	Conforms to CE:	EN 61000-6-2
Residual ripple:	< 1 %	Requirements acc. to:	EN 55011 class B
Current consumption:	< 1.5 mA (average)	Protection:	up to IP 65 depends on version
Rated voltage:	4.5 ... 35 V DC	Housing:	Plastic
On time:	100 %	Weight:	16 ... 19 g [0.564 ... 0.67 oz]
Display:	7 (99999.99 h)	Options:	
Accuracy:	22.5 ppm at 20 °C [68 °F]	HK 07.20	Flat pin connectors 0.8 x 2.8 mm [0.032 x 0.11"]
Count mode:	adding	Further Options:	Temperature range -30 ... +85 °C [-22 ... 185 °F]

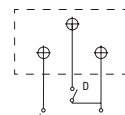

D	Function
open	counting
closed	interval

### Available types:

Type	Housing	Height of figures	Display	el. connection	Description
HK 07.40 D	Steel sheet	4 mm [0.158"]	On broad side	Solder pins	PCB-mount
HK 07.50 D	Steel sheet	4 mm [0.158"]	On narrow side	Solder pins	PCB-mount
HK 07.90 D	Plastic	4 mm [0.158"]	On broad side	Solder pins	PCB-mount wash proof
HK 07.91 D	Plastic	2.8 mm [0.11"]	On narrow side	Solder pins	PCB-mount wash proof

### Type HK 07.40 D

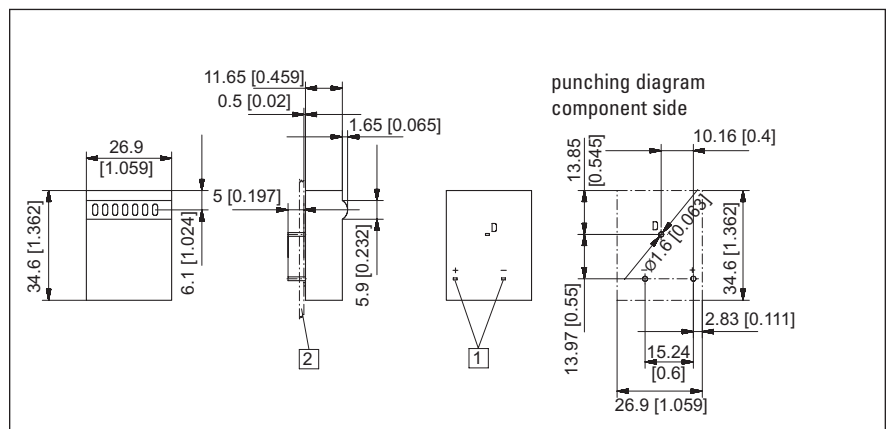

HK 07.40 d	4.5 ... 35 V
Art-No.	3.104.401.383

- 1 Potential free mounting pin 0.4 x 1.2 mm [0.016 x 0.047"]
- 2 Coil connections 0.4 x 1.2 mm [0.016 x 0.047"]

## Type HK 07.50 D

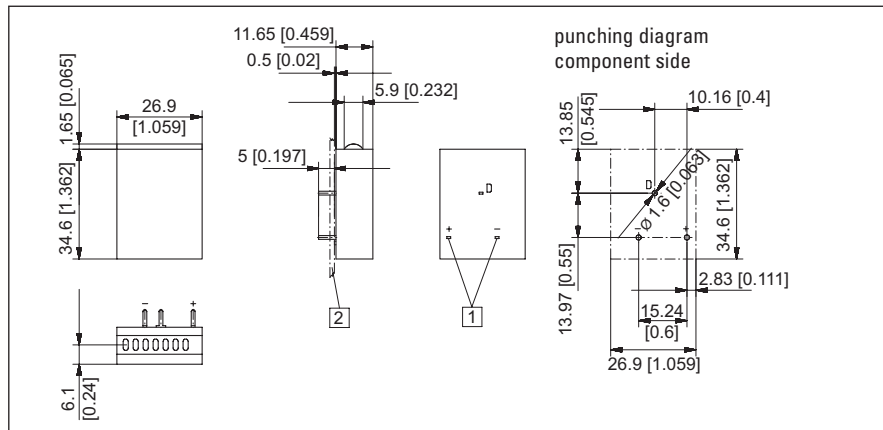

HK 07.50 D	4.5 ... 35 V	
Art-No.	3.104.500.383	

- 1 Potential free mounting pin 0.4 x 1.2 mm [0.016 x 0.047"]
- 2 Coil connections 0.4 x 1.2 mm [0.016 x 0.047"]

## Type HK 07.90 D

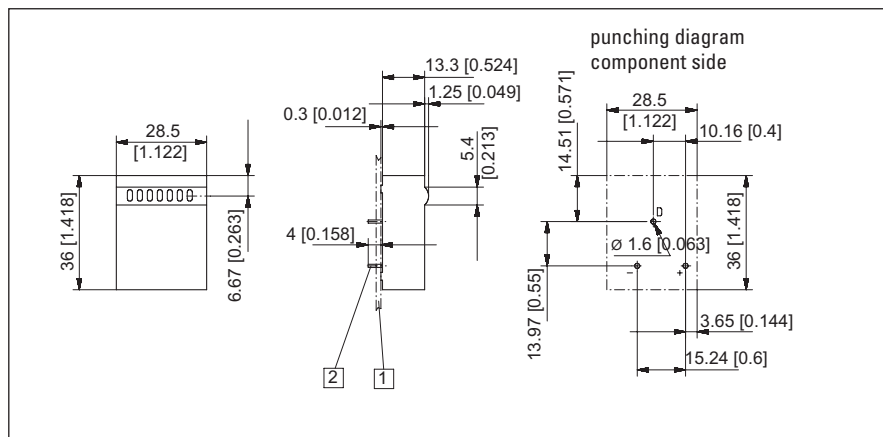

HK 07.90 D	4.5 ... 35 V	
Art-No.	3.104.900.383	

- 1 Potential free mounting pin  $\varnothing$  0.64 [0.025"]
- 2 Coil connections  $\varnothing$  0.64 [0.025"]

## Type HK 07.91 D

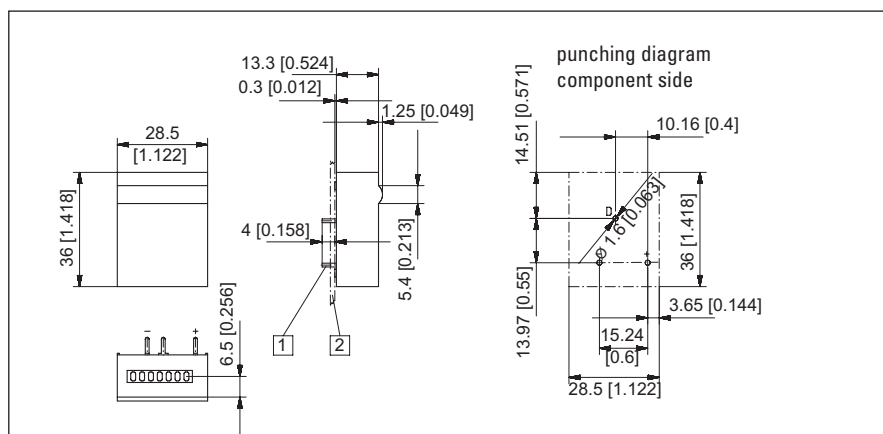

HK 07.91 D	4.5 ... 35 V	
Art-No.	3.104.910.383	

- 1 Potential free mounting pin 0.4 x 1.2 mm [0.016 x 0.047"]
- 2 Coil connections 0.4 x 1.2 mm [0.016 x 0.047"]

## Type series SHK 07.1



- 7-digit micro hour meter
- DIN-rail mounting to EN 50 022
- Base mount meter
- High shock resistance
- Low power consumption
- Small dimensions
- Large optical figures
- Data retention if power is lost
- Long service life

- Display range 99999.99h

### Applications

general time counting, installation in control cabinets

### Technical data:

Electrical connection:	clamp terminal for cable diameter up to 2.5 mm <sup>2</sup> [1612.9 square inch], tightening torque max. 0.8 Nm	Counting mode:	adding
Typ. power consumption:	at U <sub>B</sub> = 5 V DC typ. 82 mW at U <sub>B</sub> = 12 V DC typ. 135 mW at U <sub>B</sub> = 24 V DC typ. 135 mW max. 170 mW  (only every 36 s with a pulse time of 32 ms) 100 ... 130 V AC approx. 0.82 VA 187 ... 264 V AC approx. 1.8 VA	Height of figures:	1.35 x 2.8 mm [0.053 x 0.11"]
Rated voltages:	20 ... 30, 100 ... 130, 187 ... 264 V AC 50 Hz, 60Hz 4.5 ... 35 V DC	Colour of figures:	white and red on black
On time:	100 %	Reset:	no
Figures:	7 (99999.99 h)	Ambient temperature:	-10 ... +50 °C at AC [14 ... 122 °F] -10 ... +60 °C at DC [14 ... 140 °F]
Accuracy:	22.5 ppm at 20 °C [68 °F]	Mounting position:	number of wheel view horizontal (other on request)
		Protection:	up to IP 52 depends on version
		Housing:	Plastic
		Weight:	approx. 55 g [1.94 oz]
		Options:	Colour of housing: grey Flat pins: 0.8 x 6.3 mm [0.032 x 0.248"]

### Type SHK 07.1

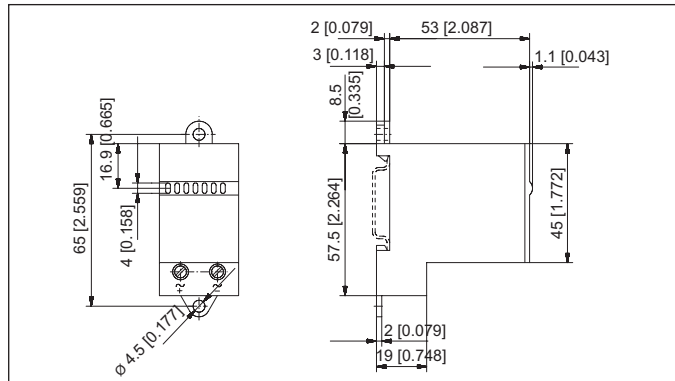

Voltage	Art-No. (V DC)	Art-No. (V AC)
4.5 ... 35	3.102.101.383	
20...30		3.102.101.310
100...130		3.102.101.312
187 ... 264		3.102.101.313*

\*standard stock model

## Type series HK 17



- 7- or 8-digit hour meter for AC or DC voltage
- Without reset
- High shock resistance
- Small dimensions
- Magnified figures
- Protection IP 65 front side
- Data retention if power is lost
- Long service life
- UL-approved

### Applications:

general counting, service interval for measurement systems (respiratory ventilators, oxygen machines, dialysis machines), small appliances, UV lamps, display panels in cars.



### Technical data:

Electrical connection:	Flat pins 0.8 x 6.3 mm [0.032 x 0.248"] with screw terminals or flat pins 0.8 x 6.3 mm [0.032 x 0.248"] tightening torque max. 0,8 Nm	Accuracy:	AC: supply frequency +30 ms DC: <0.003 % (at 24 h)
Power consumption:	10 ... 30 V DC: approx. 500 mW 36 ... 80 V DC: approx. 900 mW 100 ... 130 V DC: approx. 750 mW 20 ... 30 V AC, 50 Hz: approx. 0.3 VA 42 ... 48 V AC, 50 Hz: approx. 0.25 VA 100 ... 130 V AC, 50 Hz: approx. 0.6 VA 187 ... 264 V AC, 50Hz: approx. 1.2 VA 360 ... 440 V AC, 50 Hz: approx. 1.65 VA	Height of figures:	3.8 x 1.7 mm [1.496 x 0.67] magnified
Rated voltages:	20 ... 30, 42 ... 48, 100 ... 130, 187 ... 264, 360 ... 440 V AC 50 or 60 Hz, 10 ... 30, 36 ... 80, 100 ... 130 V DC	Colour of figures:	white and red on black
Display:	7 at AC: 99999.99 8 at DC: 999999.99	Ambient temperature:	-15 ... +50 °C [5 ... 122 °F]
		Mounting position:	any
		Protection:	IP 65 front side
		UL:	File E128604
		Housing:	Plastic, types with Protection IP 65 are sealed
		Weight:	approx. 40 g [1.411 oz]
		Options:	Counter with flat pin 0.8 x 6.3 mm [0.032 x 0.248"] Art. no. 3.138.X51.XXX

### Order code:

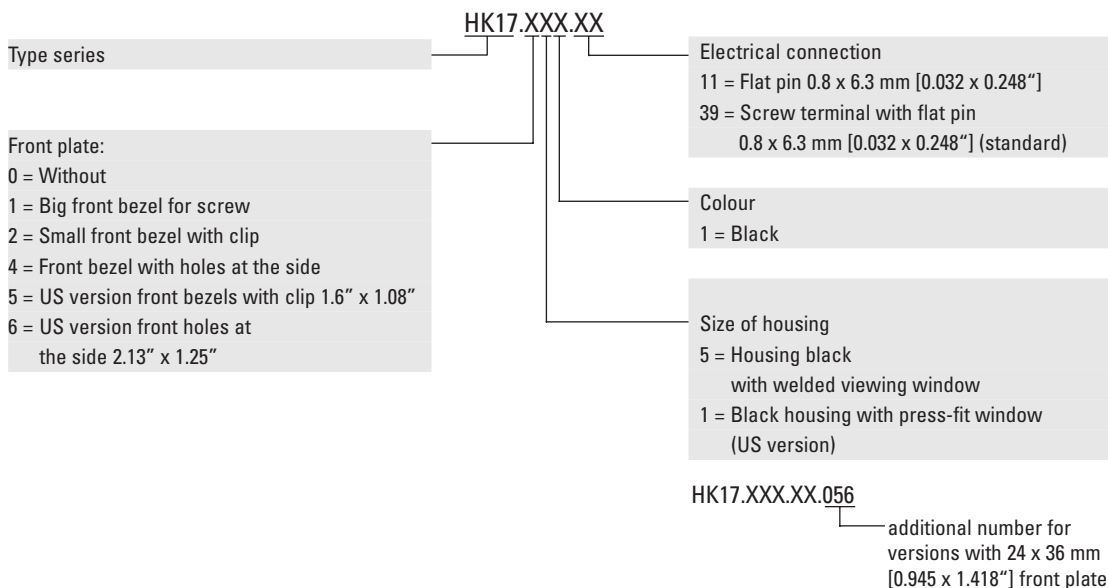

## HK 17.251.39

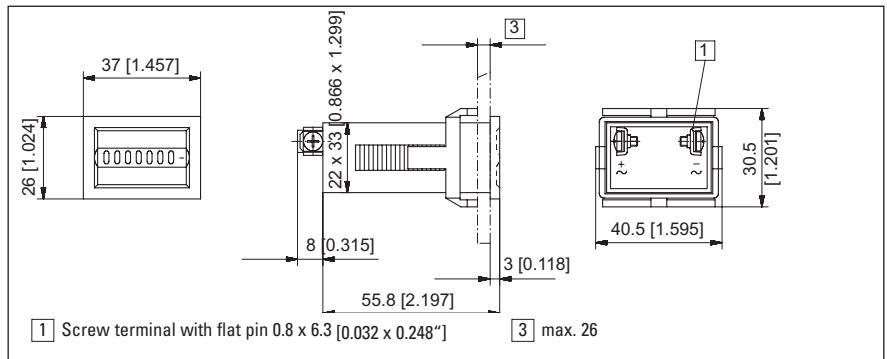

Voltage	Art-No. (AC), 50 Hz	Art-No. (AC), 60 Hz	Art-No. (V DC)
10 ... 30			3.130.251.351
20 ... 30	3.130.251.071	3.130.251.081	
36 ... 80			3.130.251.353
42 ... 48	3.130.251.072	3.130.251.082	
100 ... 130	3.130.251.074	3.130.251.084	3.130.251.381
187 ... 264	3.130.251.075	3.130.251.085	
360 ... 440	3.130.251.079	3.130.251.089	

Panel cut-out

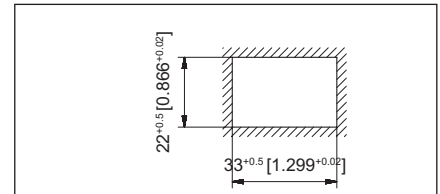

## HK 17.151.39

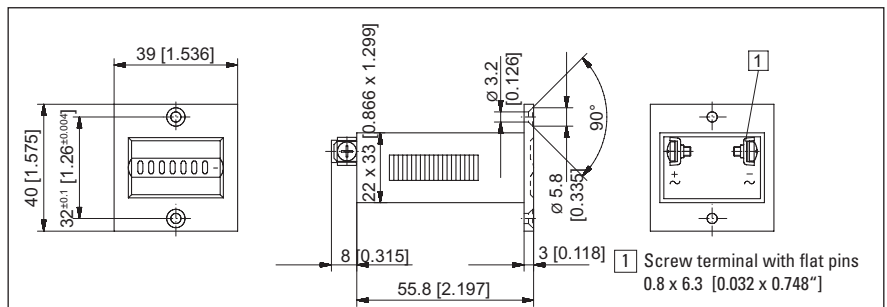

Voltage	Art-No. (AC), 50 Hz	Art-No. (AC), 60 Hz	Art-No. (V DC)
10 ... 30			3.130.151.351
20 ... 30	3.130.151.071	3.130.151.081	
36 ... 80			3.130.151.353
42 ... 48	3.130.151.072	3.130.151.082	
100 ... 130	3.130.151.074	3.130.151.084	3.130.151.381
187 ... 264	3.130.151.075	3.130.151.085	
360 ... 440	3.130.151.079	3.130.151.089	

Panel cut-out

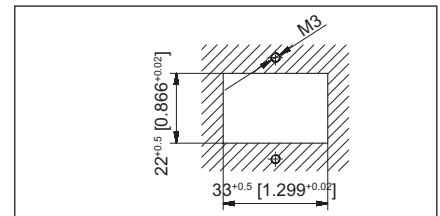

## HK 17.451.39

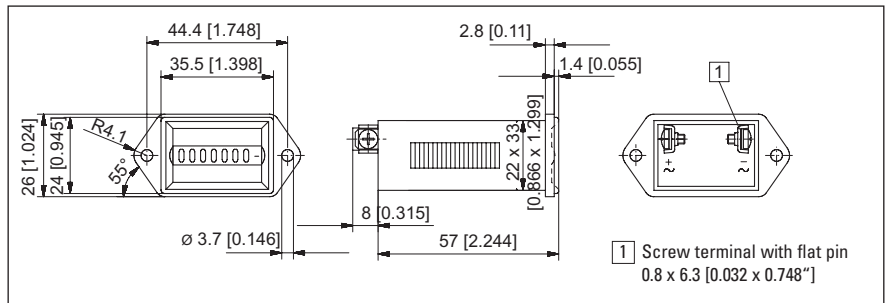

Voltage	Art-No. (AC), 50 Hz	Art-No. (AC) 60 Hz	Art-No. (V DC)
10...30			3.130.451.351
20...30	3.130.451.071	3.130.451.081	
36...80			3.130.451.353
42...48	3.130.451.072	3.130.451.082	
100...130	3.130.451.074	3.130.451.084	3.130.451.381
187...264	3.130.451.075	3.130.451.085	
360...440	3.130.451.079	3.130.451.089	

Panel cut-out

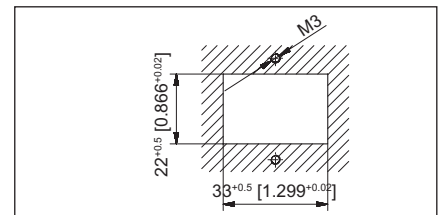

# Time meter

HK 17.051.39

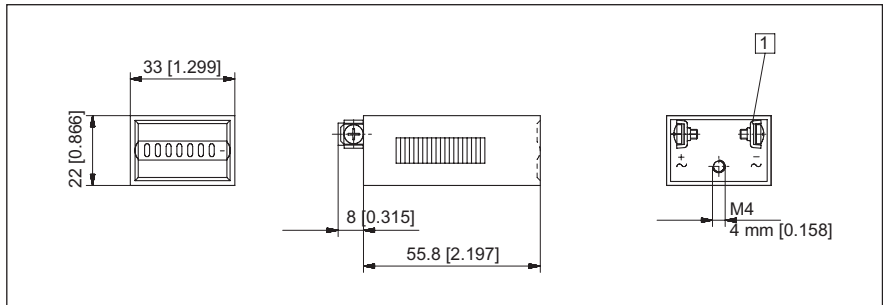

Voltage	Art-No. (AC), 50 Hz	Art-No. (AC), 60 Hz	Art-No. (V DC)
10 ... 30			3.130.051.351
20 ... 30	3.130.051.071	3.130.051.081	
36 ... 80			3.130.051.353
42 ... 48	3.130.051.072	3.130.051.082	
100 ... 130	3.130.051.074	3.130.051.084	3.130.051.381
187 ... 264	3.130.051.075	3.130.051.085	
360 ... 440	3.130.051.079	3.130.051.089	

1 Screw terminal with flat pins 0.8 x 6.3 [0.032 x 0.248"]

HK 17.251.56

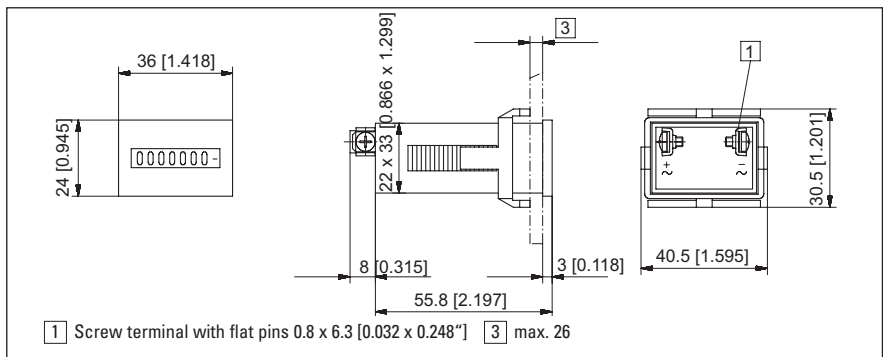

1 Screw terminal with flat pins 0.8 x 6.3 [0.032 x 0.248"] 3 max. 26

Voltage	Art-No. (V AC), 50 Hz	Art-No. (V AC), 60 Hz	Art-No. (V DC)
10 ... 30			3.130.251.351.056
20 ... 30	3.130.251.071.056	3.130.251.081.056	
36 ... 80			3.130.251.353.056
42 ... 48	3.130.251.072.056	3.130.251.082.056	
100 ... 130	3.130.251.074.056	3.130.251.084.056	3.130.251.381.056
187 ... 264	3.130.251.075.056	3.130.251.085.056	
360 ... 440	3.130.251.079.056	3.130.251.089.056	

Panel cut-out

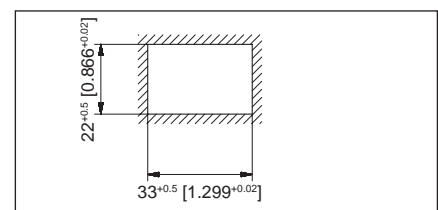



## HK 17.511

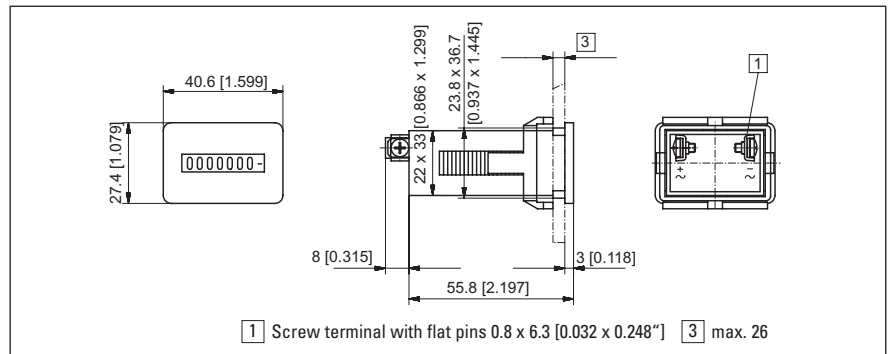

Voltage	Art-No. (AC), 50 Hz	Art-No. (AC), 60 Hz	Art-No. (V DC)
10 ... 30			3.130.511.351
20 ... 30	3.130.511.071	3.130.511.081	
36 ... 80			3.130.511.353
42 ... 48	3.130.511.072	3.130.511.082	
100 ... 130	3.130.511.074	3.130.511.084	3.130.511.381
187 ... 264	3.130.511.075	3.130.511.085	
360 ... 440	3.130.511.079	3.130.511.089	

Panel cut-out

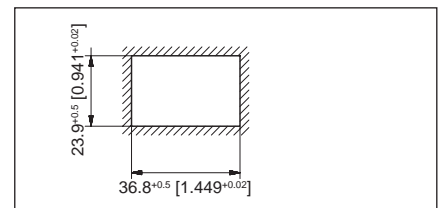

## HK 17.611

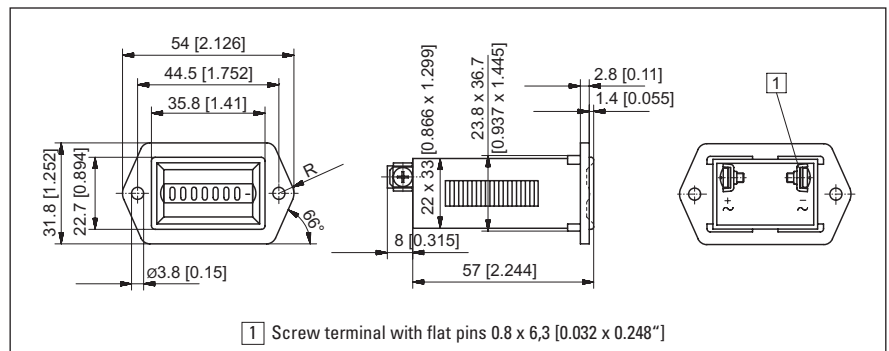

Voltage	Art-No. (AC), 50 Hz	Art-No. (AC), 60 Hz	Art-No. (V DC)
10 ... 30			3.130.611.351
20 ... 30	3.130.611.071	3.130.611.081	
36 ... 80			3.130.611.353
42 ... 48	3.130.611.072	3.130.611.082	
100 ... 130	3.130.611.074	3.130.611.084	3.130.611.381
187 ... 264	3.130.611.075	3.130.611.085	
360 ... 440	3.130.611.079	3.130.611.089	

Panel cut-out

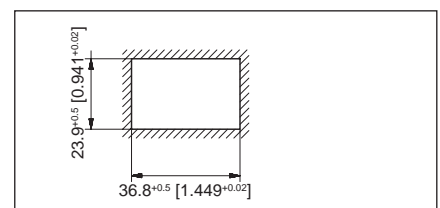

## Type series H 37



**New:**  
5 years warranty



### Product features

- 7- or 8- digit hour meter
- Without reset, high shock resistance
- Small dimensions, large optical figures
- Protection to IP 65 on the front side
- Panel mount meter with integral latching springs (H37.4)

### Your benefit

- **5 years warranty\***  
high reliability means your end product sells better
- Data retention if power is lost
- Long service life

### Applications

general time counting, service intervals for measuring devices (respiratory ventilators, oxygen machines, dialysis machines), small appliances, UV lamps, display panels in vehicles

\* subject to use in accordance with the technical data

### Technical data:

Electrical connection:	Screw terminal, tightening torque max 0,8 Nm	
Power consumption:	10 ... 30 V DC:	approx. 500 mW
	36 ... 80 V DC:	approx. 900 mW
	100 ... 130 V DC:	approx. 750 mW
	20 ... 30 V AC, 50 Hz:	approx. 0.3 VA
	42 ... 48 V AC, 50 Hz:	approx. 0.25 VA
	100 ... 130 V AC, 50 Hz:	approx. 0.6 VA
Rated voltages:	187 ... 264 V AC, 50 Hz:	approx. 1.2 VA
	20 ... 30/42 ... 48/100 ... 130/187 ... 264 V AC	
	50 or 60 Hz, 10 ... 30/36 ... 80/100 ... 130 V DC	
On time:	100 %	
Display:	7 for AC:	99999.99
	8 for DC:	999999.99
Accuracy:	AC: Supply frequency + 30 ms	
	DC: < 0.003 % (24 h)	
Count mode:	adding	
Height of figures:	4 mm [0.158"]	
Colour of figures:	white and red on black	
Reset:	no	
Ambient temperature:	-10 ... +50 °C [14 ... 122 °F]	
Mounting position:	any	
Protection:	IP 65 (front-side, built in)	
Housing:	Plastic	
	IP 65 are sealed	

Weight:		
H 37 approx.	50 g [1.764 oz]	
Slip on bezel 37.1	6 g [0.212 oz]	
Slip on bezel 37.2	2 g [0.071 oz]	
Options:	1. Colour of housing: grey	Art. no. 3.130.X50.XXX
	2. Electrical connection:	
	a) Flat pins 0.8 x 6,3 mm [0.032 x 0.248"]	Art-No.: 3.24X.20X.XXX.011
	b) Screw terminal with terminal cover	Art-No.: 3.24X.20X.XXX.456
Accessories:		
Slip on bezel 37.1	black:	Art-No.: T008.161
	grey:	Art-No.: T008.160
Slip on bezel 37.2	black:	Art-No.: T008.165
	grey:	Art-No.: T008.164
Terminal cover <b>KA37</b>	2 pcs required per counter Art-No.: T051.687	
Seal:	Art-No.: N511015	
	for H 37.2 and H 37.4	
	Art-No.: N511029 for H 37 and H 37.5	
Approvals:	UL for USA and Canada E128604	

## H 37

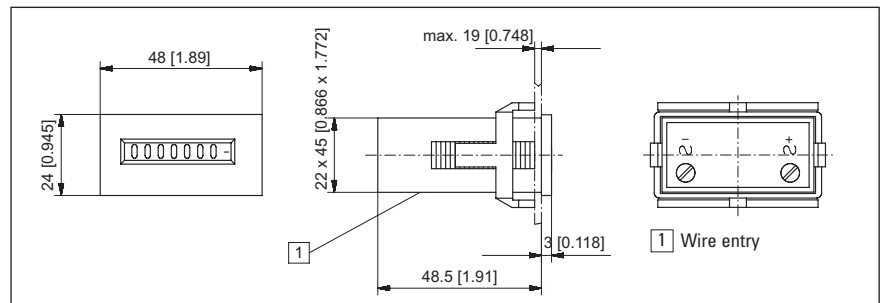

Voltage	Art-No. (AC), 50 Hz	Art-No. (AC), 60 Hz	Art-No. (V DC)
10 ... 30			3.240.201.351
20 ... 30	3.240.201.071	3.240.201.081	
36 ... 80			3.240.201.353
42 ... 48	3.240.201.072	3.240.201.082	
100 ... 130	3.240.201.074	3.240.201.084	3.240.201.381
187 ... 264	3.240.201.075	3.240.201.085	

### Panel cut-out

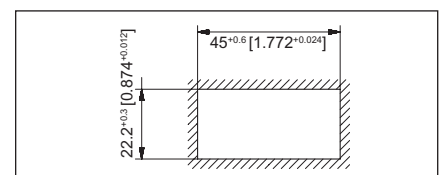

## H 37.1

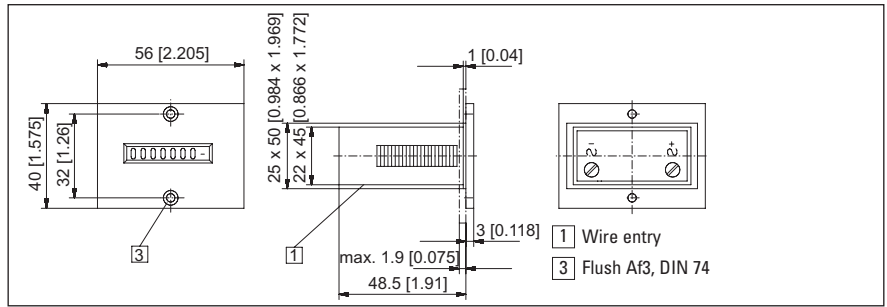

Voltage	Art-No. (AC), 50 Hz	Art-No. (AC), 60 Hz	Art-No. (V DC)
10 ... 30			3.241.201.351*
20 ... 30	3.241.201.071	3.241.201.081	
36 ... 80			3.241.201.353
42 ... 48	3.241.201.072	3.241.201.082	
100 ... 130	3.241.201.074	3.241.201.084	3.241.201.381
187 ... 264	3.241.201.075	3.241.201.085	

Panel cut-out

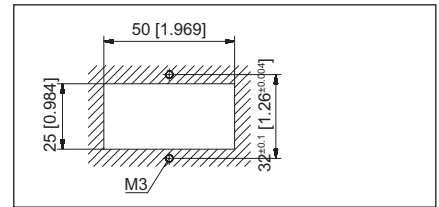

## H 37.2

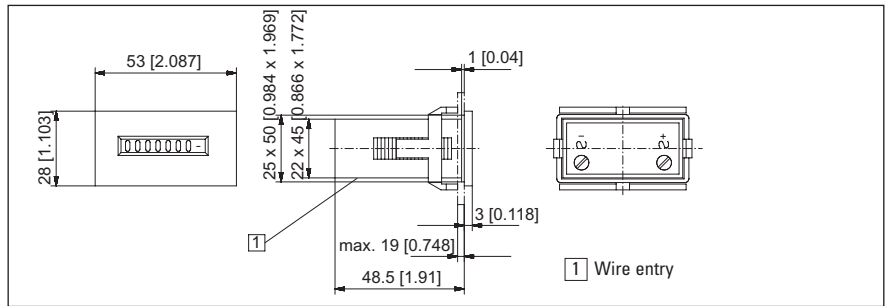

Voltage	Art-No. (AC), 50 Hz	Art-No. (AC), 60 Hz	Art-No. (V DC)
10 ... 30			3.242.201.351*
20 ... 30	3.242.201.071	3.242.201.081	
36 ... 80			3.242.201.353
42 ... 48	3.242.201.072	3.242.201.082	
100 ... 130	3.242.201.074	3.242.201.084	3.242.201.381
187 ... 264	3.242.201.075*	3.242.201.085	

Panel cut-out

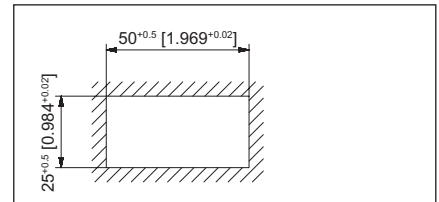

## H 37.4

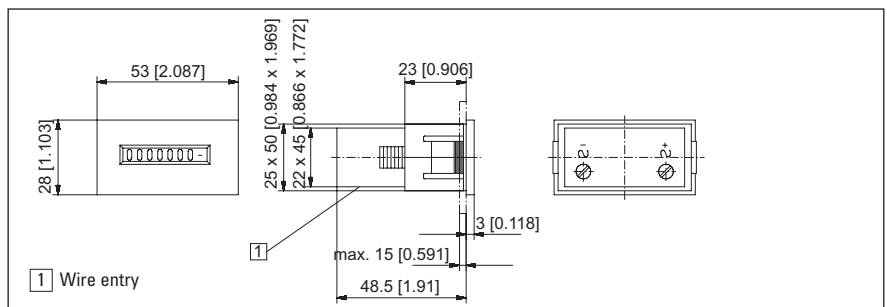

Voltage	Art-No. (AC), 50 Hz	Art-No. (AC), 60 Hz	Art-No. (V DC)
10 ... 30			3.244.201.351*
20 ... 30	3.244.201.071	3.244.201.081	
36 ... 80			3.244.201.353
42 ... 48	3.244.201.072	3.244.201.082	
100 ... 130	3.244.201.074	3.244.201.084	3.244.201.381
187 ... 264	3.244.201.075*	3.244.201.085	

Panel cut-out

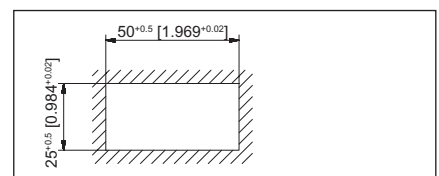

\*standard stock model

## H 37.5

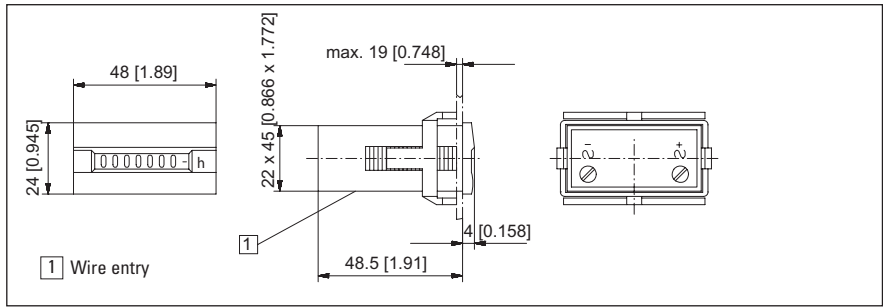

Voltage	Art-No. (AC), 50 Hz	Art-No. (AC), 60 Hz	Art-No. (V DC)
10 ... 30			3.245.201.351
20 ... 30	3.245.201.071	3.245.201.081	
36 ... 80			3.245.201.353
42 ...	3.245.201.072	3.245.201.082	
100 ... 130	3.245.201.074	3.245.201.084	3.245.201.381
187 ... 264	3.245.201.075	3.245.201.085	

Panel cut-out

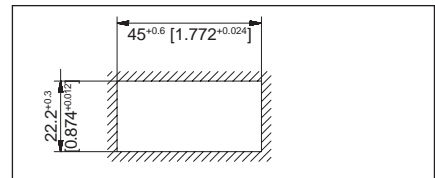

## Slip on bezel 37.1

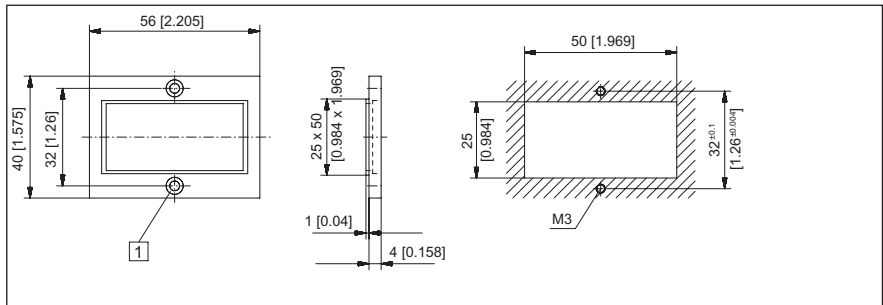

1 Countersunk Af3, DIN 74

black: Art-No. T008.161

## Slip on bezel 37.2



Panel cut-out 50 x 25 mm [1.969 x 0.984"]

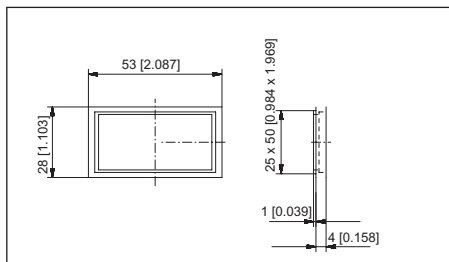

black: Art-No.: T008.165

## Terminal cover KA 37



black: Art-No.: T051.687  
(2 pcs required/counter)



Sealing gasket for H37 and H37.5:  
Art-No.: N511.029

Sealing gasket for H37.2 and H37.4:  
Art-No.: N511.015

## Time meter H 37S

- 7- or 8-digit hour meter
- Small dimensions, large optical figures
- Data retention if power is lost, long service life

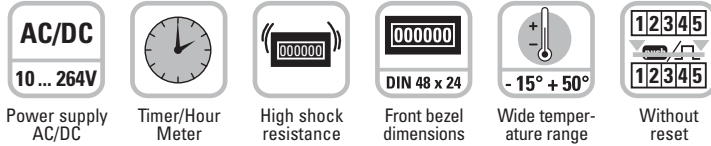

### Versatile

- For voltage ranges  
10...30 V DC, 100...130 V AC  
and 187...264 V AC
- Large optical figures
- Protection to IP 65 on the front side
- Suitable for any mounting position
- Without reset, therefore tamper-proof



### Cost-effective

- Thanks to ingenious manufacturing technology and large production runs

### Suits perfectly

- For panel cut-outs 45 x 22 mm with front panel dimensions 48 x 24 mm
- 7- or 8-digits
- High shock and impact resistance
- Simple, secure mounting using latch fastening

### Applications

- General time counting
- Service intervals for measuring devices (respiratory ventilators, oxygen machines, dialysis machines)
- Small appliances
- UV lamps
- Display panels in vehicles
- Compressors
- Air-conditioning devices etc.

### Technical data:

Electrical connection:	Screw terminal, tightening torque max 0,8 Nm	Housing:	Plastic
Power consumption:	10 ... 30 V DC: approx. 500 mW 100 ... 130 V DC: approx. 750 mW 187 ... 264 V AC, 50 Hz: approx. 1.2 VA		IP 65 are sealed
Rated voltages:	100 ... 130/187 ... 264 V AC 10 ... 30 V DC	Weight:	
On time:	100 %	H 37 approx.	50 g [1.764 oz]
Display:	7 at AC: 99999.99 8 at DC: 999999.99 0.01 h -> 36 s	Slip on bezel 37.1	6 g [0.212 oz]
Accuracy:	AC: Supply frequency + 30 ms DC: < 0.003 % (24 h)	Slip on bezel 37.2	2 g [0.071 oz]
Count mode:	adding	Accessories:	
Height of figures:	4 mm [0.158"]	Slip on bezel 37.1	black: Art-No.: T008.161 grey: Art-No.: T008.160
Colour of figures:	white and red on black	Slip on bezel 37.2	black: Art-No.: T008.165 grey: Art-No.: T008.164
Reset:	no	Terminal cover <b>KA37</b>	2 pcs required per counter Art-No.: T051.687
Ambient temperature:	-10 ... +50 °C [14 ... 122 °F]	Seal:	Art-No.: N511015 for H 37.2 and H 37.4 Art-No.: N511029 for H 37 and H 37.5
Mounting position:	any	Approvals:	UL for USA and Canada E128604
Protection:	IP 65 (front-side, built in)		

## Time meter H 37S - Accessories

### H 37S

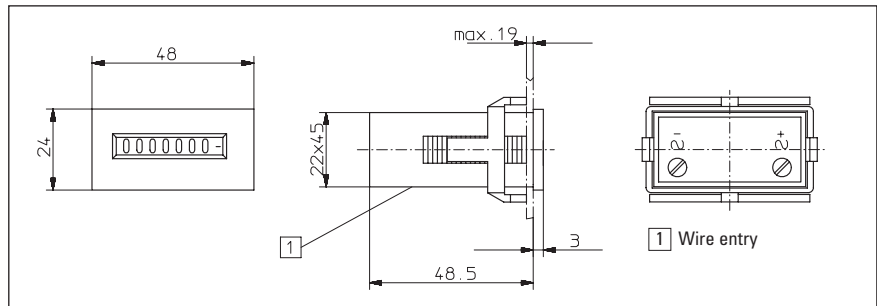

Voltage	Art-No.. (AC), 50 Hz	Art-No. (V DC)
10 ... 30		3.24S.201.351
100 ... 130	3.24S.201.074	
187 ... 264	3.24S.201.075	

Panel cut-out

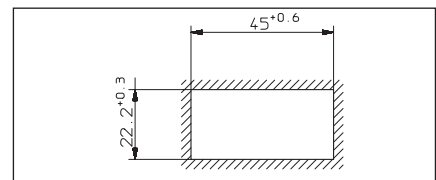

### Slip on bezel 37.1

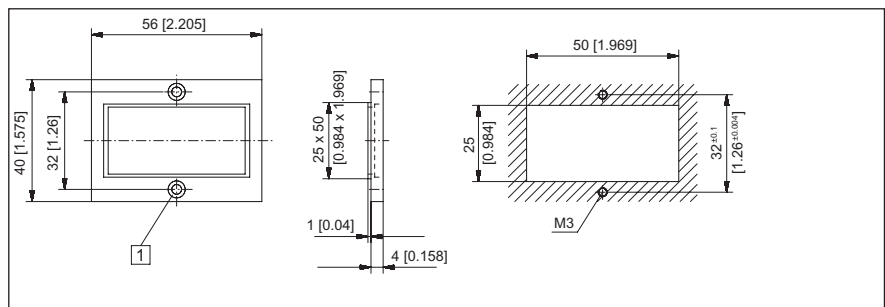

1 Countersunk Af3, DIN 74

black: Art-No. T008.161

### Slip on bezel 37.2



Panel cut-out 50 x 25 mm [1.969 x 0.984"]

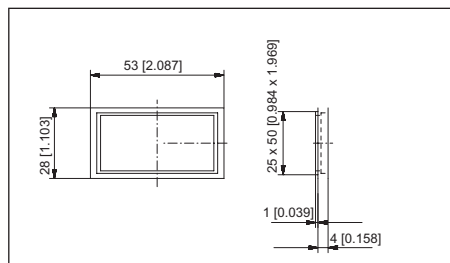

black: Art-No.: T008.165

### Terminal cover KA 37



black: Art-No.: T051.687  
(2 pcs required/counter)



Sealing gasket for H37 and H37.5:  
Art-No.: N511.029

Sealing gasket for H37.2 and H37.4:  
Art-No.: N511.015

## Time meter H 57



**New:**  
5 years warranty



### Product features

- 7- or 8-digit hour meter
- High shock and impact resistance
- Without reset, small dimensions
- Large optical figures
- Protection IP 52, suitable for any mounting position

### Your benefit

- **5 years warranty\***  
high reliability means your end product sells better
- Data retention if power is lost
- Long service life

### Applications

general time counting, service intervals for measuring devices (respiratory ventilators, oxygen machines, dialysis machines), small appliances, UV lamps, display panels in vehicles

\* subject to use in accordance with the technical data

### Technical data:

Electrical connection:	screw terminal for cable diameter up to 2.5 mm <sup>2</sup> [1612.9 square inch] tightening torque max. 0.8 Nm		Weight:	H 57: 48 g [1.673 oz]; AH 57: 84 g [2.963"]
Power consumption:	10 ... 30 V DC:	approx. 500 mW	Base mount socket No. 48	36 g [1.27"]
	100 ... 130 V DC:	approx. 750 mW	Slip-on bezel 55	8 g [0.282"]
	20 ... 30 V AC, 50 Hz:	approx. 0.3 VA	Slip-on bezel 72	13 g [0.459"]
	42 ... 48 V AC, 50 Hz:	approx. 0.25 VA	Operating indicator of the running time meter:	
	100 ... 130 V AC, 50 Hz:	approx. 0.6 VA	AC:	Fast rotating wheel with red dashes
	187 ... 264 V AC, 50 Hz:	approx. 1.2 VA	DC:	1/100 h display turns continuously by 1 digit in 36 s
	360 ... 440 V AC, 50 Hz:	approx. 1.65 VA	Test voltage:	2000 V AC, 50 Hz for AC counters
Rated voltages:	20...30/42...48/100...130/187...264/360...440 V AC, 50 or 60 Hz, 10...30/100...130 V DC		Options:	further voltages on request
On time:	100 %		Counter with wire entry from behind, screw fixing from rear.	Art-No. 3.228.401.XXX.044
Display:	7 at AC 99999.99 8 at DC 999999.99		Colour of housing:	grey: Art-No. 3.22X.400.XXX
Accuracy:	AC: Supply frequency + 30 ms DC: < 0.003 % (24 h)		Flat pin	0.8 x 6.3 mm [0.032 x 0.248"] Art-No. 3.228.401.XXX
Count mode:	adding		Welded cover (IP 65 from front)	
Height of figures:	4 mm [0.158"]		IP 65 version:	order code: 3.22X.XXX.XXX.422
Colour of figures:	white and red on black		Seals required between the counter and the bezel:	
Ambient temperature:	-15 ... +50°C [5 ... 122 °F]		H 57:	N.511.018
Mounting position:	any		H 57.55:	N.511.018 + N.511.017
Protection:	up to IP 52, DIN 40 050 front side		H 57.72:	N.511.018 + N.511.016
Housing:	plastic		(with the IP 65 version, the seal is included in the delivery)	
			Approvals:	UL for USA and Canada E128604

### H 57

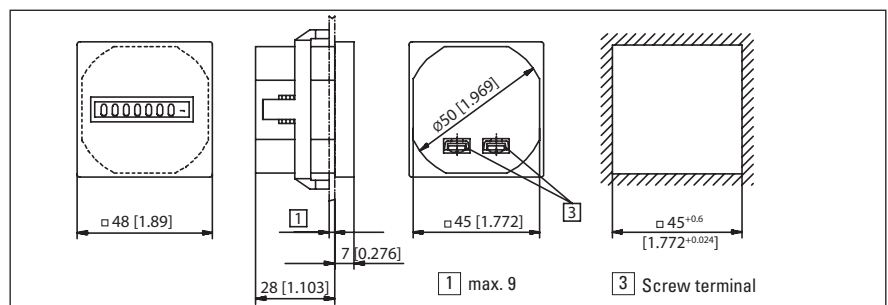

Voltage	Art-No. (AC), 50 Hz	Art-No. (AC), 60 Hz	Art-No. (V DC)
10 ... 30			3.220.401.351*
20 ... 30	3.220.401.071*	3.220.401.081*	
42 ... 48	3.220.401.072	3.220.401.082	
100 ... 130	3.220.401.074*	3.220.401.084*	3.220.401.381
187 ... 264	3.220.401.075*	3.220.401.085*	
360 ... 440	3.220.401.079	3.220.401.089	

\*standard stock model

Further standard stock models:  
3.220.401.075.422 187 ... 264 V AC, IP 65  
3.220.401.351.422 10 ... 30 V DC, IP 65

Type series AH 57

AH 57



New:  
5 years warranty

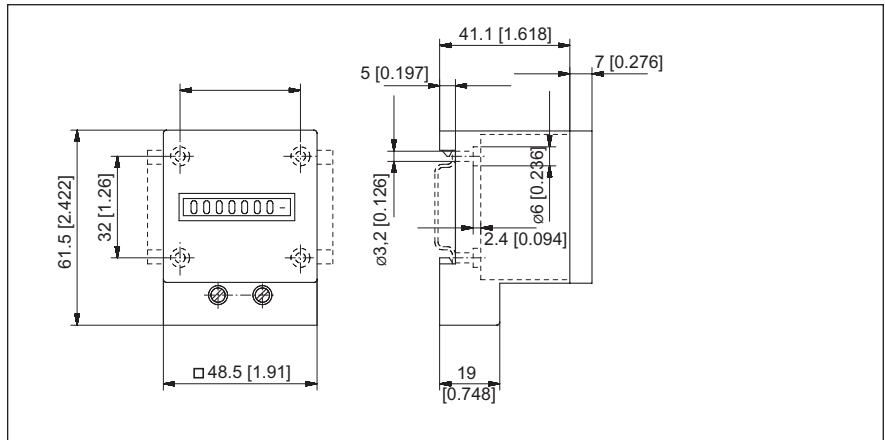

Voltage	Art-No. (AC), 50 Hz	Art-No. (AC), 60 Hz	Art-No. (V DC)
10 ... 30			3.223.401.351*
20 ... 30	3.223.401.071	3.223.401.081	
42 ... 48	3.223.401.072	3.223.401.082	
100 ... 130	3.223.401.074*	3.223.401.084 *	3.223.401.381
187 ... 264	3.223.401.075*	3.223.401.085*	
360 ... 440	3.223.401.079	3.223.401.089	

\*standard stock model

Slip-on bezel 55 x 55

black: Art-No. T008.171  
grey: Art-No. T008.170



Slip-on bezel 72 x 72

black: Art-No. T008.177  
grey: Art-No. T008.176



Slip-on bezel 55 x 55

black: Art-No. G008.040  
grey: Art-No. G008.041



For hour meter H57 with flat pins  
Art-No. 3.228.401.XXX

Slip-on bezel Ø 72 for Panel cut-out  
Ø 60 mm, colour black Art-No. N.510.226





## Time meter H 57S

- 7- or 8-digit hour meter
- Without reset, small dimensions
- Large optical figures
- Suitable for any mounting position

<b>AC/DC</b> 10 ... 264V	Timer/Hour Meter	High shock resistance	Front bezel dimensions DIN 48 x 48	Wide temper- ature range - 15° + 50°	Without reset
Power supply AC/DC					

### Versatile

- For voltage ranges  
10...30 V DC, 100...130 V AC  
and 187...264 V AC
- Large optical figures
- Protection IP 52
- Suitable for any mounting position
- Without reset, therefore tamper-proof



### Cost-effective

- Thanks to ingenious manufacturing technology and large production runs

### Suits perfectly

- For panel cut-outs 45 x 45 mm with front panel dimensions 48 x 48 mm
- UL approved
- 7- or 8-digits
- High shock and impact resistance
- Simple, secure mounting using latch fastening

## Applications

- General time counting
- Service intervals for measuring devices (respiratory ventilators, oxygen machines, dialysis machines)
- Small appliances
- UV lamps
- Display panels in vehicles
- Compressors
- Air-conditioning devices etc.

### Technical data:

Electrical connection:	screw terminal for cable diameter up to 2,5 mm <sup>2</sup> [1612.9 square inch] tightening torque max. 0,8 Nm	Ambient temperature:	-15 ... +50°C [5 ... 122 °F] non-condensing
Power consumption:	10 ... 30 V DC: approx. 500 mW 100 ... 130 V DC: approx. 750 mW 187 ... 264 V AC, 50 Hz: approx. 1.2 VA	Mounting position:	any
Rated voltages:	100...130/187...264 V AC, 50 Hz 10...30 V DC	Protection:	up to IP 52, DIN 40 050 front side
On time:	100 %	Housing:	Plastic
Display:	7 at AC 99999.99 8 at DC 999999.99 0.01 h -> 36 s	Weight:	H 57: 48 g [1.673 oz]; AH 57: 84 g [2.963"]
Accuracy:	AC: Supply frequency + 30 ms DC: < 0.003 % (24 h)	Base mount socket No. 48	36 g [1.27"]
Count mode:	adding	Slip-on bezel 55	8 g [0.282"]
Height of figures:	4 mm [0.158"]	Slip-on bezel 72	13 g [0.459"]
Colour of figures:	white and red on black	Operating indicator of the running time meter:	
		AC:	Fast rotating wheel with red dashes
		DC:	1/100 h display turns continuously by 1 digit in 36 s
		Test voltage:	2000 V AC , 50 Hz for AC counters
		Approvals:	UL for USA and Canada E128604

## Type series H 57 S

H 57S

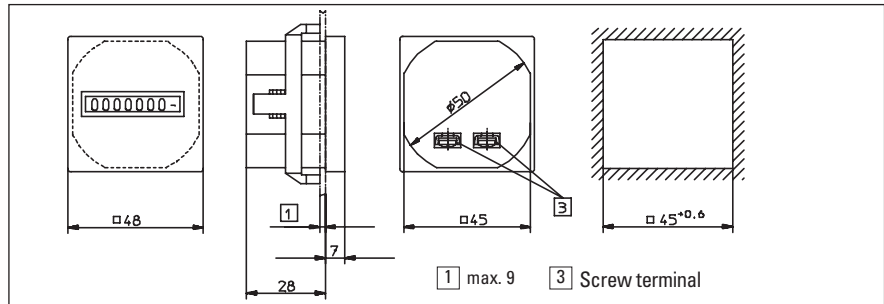

Voltage	Art.No. (AC), 50 Hz	Art.No.(V DC)
10 ... 30		3.22S.401.351
100 ... 130	3.22S.401.074	
187 ... 264	3.22S.401.075	

### Slip-on bezel 55 x 55

black: Art-No. T008.171  
grey: Art-No. T008.170



### Slip-on bezel 72 x 72

black: Art-No. T008.177  
grey: Art-No. T008.176



For hour meter H57 with flat pins  
Art-No. 3.228.401.XXX



**Slip-on bezel Ø 72 for Panel cut-out**  
Ø 60 mm, colour black Art-No. N.510.226



## Type series HR 76



- 6-digit hour meter for round panel cut out
- Low cost
- **High shock resistance**
- Low power consumption
- Small dimension
- Magnified figures
- Waterproof
- Protection IP 65
- Data retention if power is lost
- UL-approval

### Applications:

general counting,  
utility vehicles, construction  
machines, generators,  
fork-lift trucks, car washes,  
outside areas

### Technical data:

Electrical connection:	Flat pins 0.8 x 6.3 mm [0.032 x 0.248"]	Reset:	no
Power consumption:	AC max. 0.4 VA 12 V DC: max. 0.08 W 48 V DC: max. 0.7 W	Ambient temperature:	-30 ... +65 °C [-22 ... 149 °F]
Rated voltages:	115/230 V AC, ±10 %, 50/60 Hz, 10 ... 80 V DC	Mounting position:	any
On time:	100 %	Protection:	IP 65
Display:	6 (99999.9 h)	Housing:	Plastic
Count mode:	adding	Weight:	HR 76.1: 56 g [1.975 oz] HR 76.2: 54 g [1.905 oz]
Height of figures:	3.5 mm [0.138"]	Options:	Accuracy: < 0.02 % over the full range
Colour of figures:	white on black	UL:	E128604

### HR 76.2

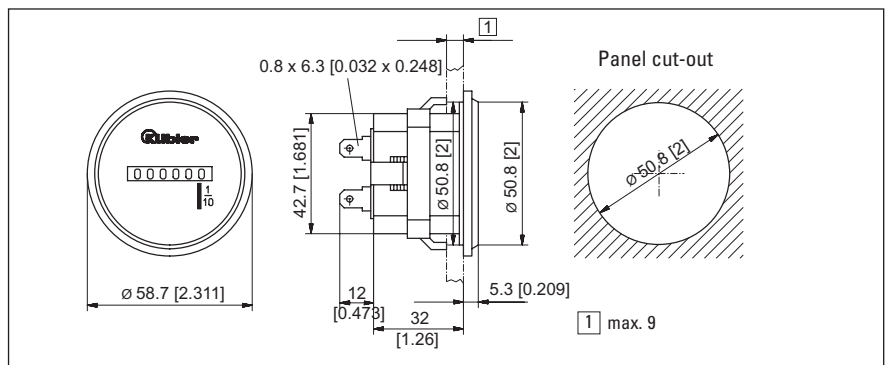

V	Art-No. (AC, 50/60 Hz)	Art-No. (DC)
10 ... 80		0.135.200.373
115	0.135.200.301	
230	0.135.200.302	

### HR 76.1

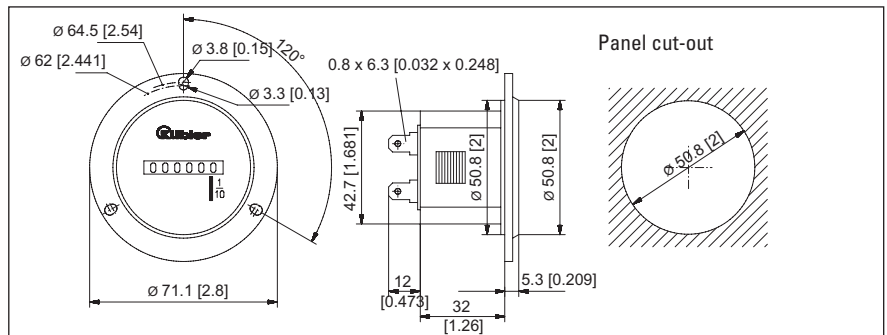

V	Art-No. (AC, 50/60 Hz)	Art-No. (DC)
10 ... 80		0.135.100.373*
115	0.135.100.301*	
230	0.135.100.302*	

separate front cover sealing gasket  
N511 150

\*standard stock model

## Type series HB 26



- 6-digit hour meter with reset
- High shock resistance
- Magnified figures; 4.5 mm [0.177"] high
- Data retention if power is lost
- Long service life
- Plug-in versions

### Applications:

Indication of machine run time or time between services.  
Machine utilisation timing for pricing etc.



### Technical data:

Electrical connection:	cable: 2 x 0.5 mm <sup>2</sup> [0.00077 square yards], NYFAZ, 0.5 m [0.547 yards] long AC: grey/grey, DC: red +, black – type HB 26.01.3 round pins (pluggable in socket box 945.2)
Power consumption:	10 ... 30 V DC: approx. 500 mW 36 ... 80 V DC: approx. 900 mW 100 ... 130 V DC: approx. 750 mW 20 ... 30 V AC: approx. 0.3 VA 42 ... 48 V AC: approx. 0.25 VA 100 ... 130 V AC: approx. 0.6 VA 187 ... 264 V AC: approx. 1.2 VA 360 ... 440 V AC: approx. 1.65 VA
Rated voltages:	20 ... 30/42 ... 48/100 ... 130/187 ... 264/ 360...440 V AC, 50 or 60 Hz, 10 ... 30/36 ... 80/100 ... 130 V DC
Display:	6: 99999.9 h
Accuracy:	AC: Supply frequency + 30 ms DC: < 0.003 % (24 h)
Height of figures:	4.5 mm [0.177"]
Colour of figures:	white and red on black
Ambient temperature:	-15° ... +50 °C [5 ... 122 °F]
Mounting position:	any
Protection:	IP 41 front side flexible sealing cover K1: IP 54 (front) Transparent cover Dv U. Dvs: IP 55 (front)
Housing:	plastic

Weight:	approx. 45 g [1.587 oz]
Options:	different voltages extended temperature range on request key-locking 0-reset: Art-No.: 3.160.XX7.XXX flat pin 0.8 x 6.3 mm [0.032 x 0.248"] without flat pin rt-No.: .168.X11.XXX flat pin 0.8 x 2.8 mm [0.032 x 0.11"] with socket box Art-No.: 3.167.X.11.XXX

Accessories:	socket box 945.2 Art-No.: G.008.434 sealing cover K1 black Art-No.: G.008.301 only for front panel 3 50 x 60
--------------	---

Front bezel:	F1B beige Art-No.: G.007.501 F1B black Art-No.: G.007.502
--------------	--

Dummy housing 25 x 50 mm [0.984 x 1.969"]	black: Art-No.: T.005.753
---	---------------------------

HB 26.21 vs



### HB 26.11

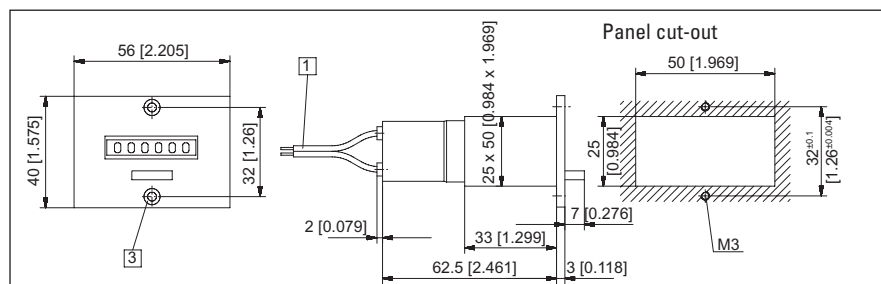

Voltage	Art-No. (AC), 50 Hz	Art-No. (AC), 60 Hz	Art-No. (V DC)
10 ... 30			3.160.111.351*
20 ... 30	3.160.111.071	3.160.111.081	
36 ... 80			3.160.111.353
42 ... 48	3.160.111.072	3.160.111.082	
100 ... 130	3.160.111.074	3.160.111.084	3.160.111.381
187 ... 264	3.160.111.075*	3.160.111.085	
360 ... 440	3.130.111.079	3.160.111.089	

- 1 Connection cable, 2 x 0.5 mm<sup>2</sup> [0.00077 square yards], NYFAZ, 0.5 m long
- 3 Countersunk Af3, DIN 74

\*standard stock model

# Time meter

HB 26.21

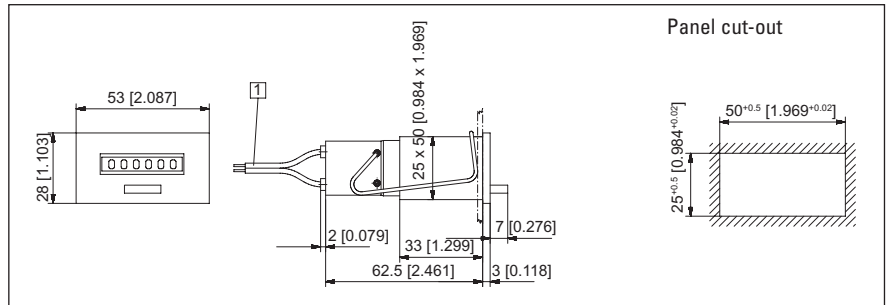

Voltage	Art-No. (AC), 50 Hz	Art-No. (AC), 60 Hz	Art-No. (V DC)
10 ... 30			3.160.211.351*
20 ... 30	3.160.211.071*	3.160.211.081	
36 ... 80			3.160.211.353
42 ... 48	3.160.211.072	3.160.211.082	
100 ... 130	3.160.211.074	3.160.211.084	3.160.211.381
187 ... 264	3.160.211.075*	3.160.211.085	
360 ... 440	3.160.211.079	3.160.211.089	

1 Connection cable, 2 x 0.5 mm<sup>2</sup> [0.00077 square yards], NYFAZ, 0,5 m [0.547 yard] long

HB 26.31

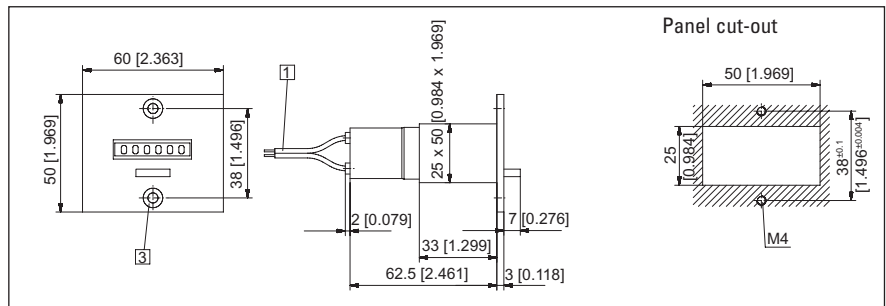

Voltage	Art-No. (AC), 50 Hz	Art-No. (AC), 60 Hz	Art-No. (V DC)
10 ... 30			3.160.311.351
20 ... 30	3.160.311.071	3.160.311.081	
36 ... 80			3.160.311.353
42 ... 48	3.160.311.072	3.160.311.082	
100 ... 130	3.160.311.074	3.160.311.084	3.160.311.381
187 ... 264	3.160.311.075	3.160.311.085	
360 ... 440	3.160.311.079	3.160.311.089	

1 Cable connection 2 x 0.5 mm<sup>2</sup> [0.00077 square yards], NYFAZ, 0,5 m [0.547 yard] long

3 Countersunk Bf4, DIN 74

HB 26.01.3

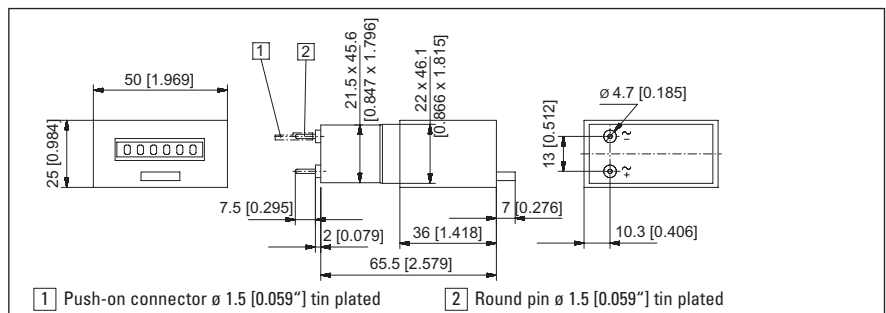

1 Push-on connector  $\varnothing$  1.5 [0.059"] tin plated

2 Round pin  $\varnothing$  1.5 [0.059"] tin plated

Voltage	Art-No. (AC), 50 Hz	Art-No. (AC), 60 Hz	Art-No. (V DC)
10 ... 30			3.165.011.351
20 ... 30	3.165.011.071	3.165.011.081	
36 ... 80			3.165.011.353
42 ... 48	3.165.011.072	3.165.011.082	
100 ... 130	3.165.011.074	3.165.011.084	3.165.011.381
187 ... 264	3.165.011.075	3.165.011.085	
360 ... 440	3.165.011.079	3.165.011.089	

Socket box 945.2

## K1 HB 26.31

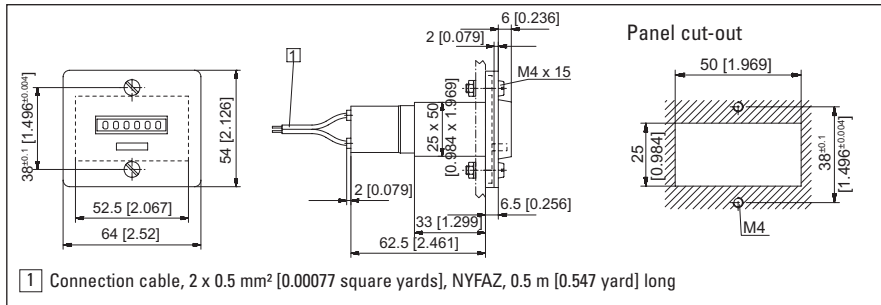

Voltage	Art-No. (AC), 50 Hz	Art-No. (AC), 60 Hz	Art-No. (V DC)
10 ... 30			3.160.611.351
20 ... 30	3.160.611.071	3.160.611.081	
36 ... 80			3.160.611.353
42 ... 48	3.160.611.072	3.160.611.082	
100 ... 130	3.160.611.074	3.160.611.084	3.160.611.381
187 ... 264	3.160.611.075	3.160.611.085	
360 ... 440	3.160.611.079	3.160.611.089	

## Dv HB 26.31

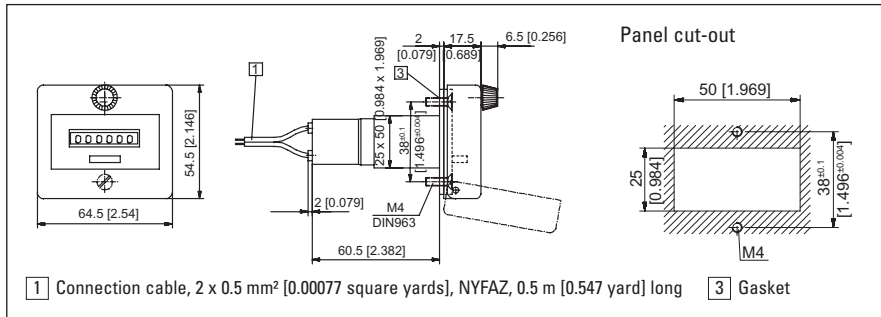

Voltage	Art-No. (AC), 50 Hz	Art-No. (AC), 60 Hz	Art-No. (V DC)
10 ... 30			3.160.711.351
20 ... 30	3.160.711.071	3.160.711.081	
36 ... 80			3.160.711.353
42 ... 48	3.160.711.072	3.160.711.082	
100 ... 130	3.160.711.074	3.160.711.084	3.160.711.381
187 ... 264	3.160.711.075	3.160.711.085	
360 ... 440	3.160.711.079	3.160.711.089	

## Dvs HB 26.31

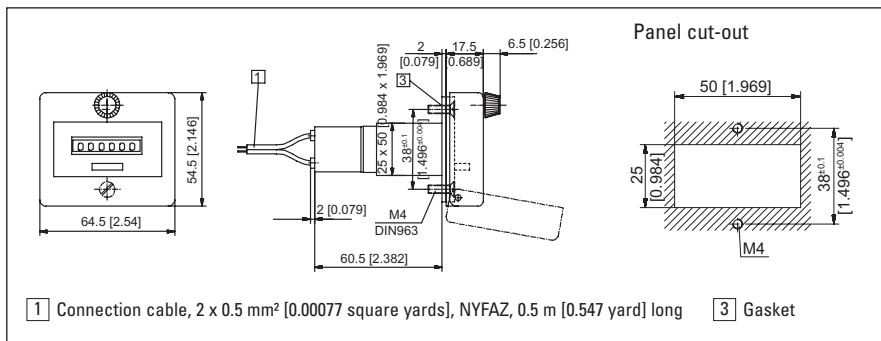

Voltage	Art-No. (AC), 50 Hz	Art-No. (AC), 60 Hz	Art-No. (V DC)
10 ... 30			3.160.811.351
20 ... 30	3.160.811.071	3.160.811.081	
36 ... 80			3.160.811.353
42 ... 48	3.160.811.072	3.160.811.082	
100 ... 130	3.160.811.074	3.160.811.084	3.160.811.381
187 ... 264	3.160.811.075	3.160.811.085	
360 ... 440	3.160.811.079	3.160.811.089	

## Type series HB 27



- 7-digit hour meter
- High shock resistance
- Without reset
- Magnified figures (4.5 mm) [0.177"]
- Data retention even if power is lost
- Long service life

### Applications:

general counting,  
service interval for  
measurement systems  
(respiratory ventilators, oxygen  
machines, dialysis machines),  
small appliances, UV lamps,  
display panels in cars.

### Technical data:

Electrical connection:	Cable: 2 x 0.5 mm <sup>2</sup> [0.00077 square yards], NYFAZ, 0.5 m [0.547 yard] long AC: grey/grey DC: red +, black- Type HB 27.00.3 with round pins (pluggable in socket box 945.2) Test voltage: 2000 V AC, 50 Hz for AC-counters
Power consumption:	10 ... 30 V DC: approx. 500 mW 36 ... 80 V DC: approx. 900 mW 100 ... 130 V DC: approx. 750 mW 20 ... 30 V AC: approx. 0.3 VA 42 ... 48 V AC: approx. 0.25 VA 100 ... 130 V AC: approx. 0.6 VA 187 ... 264 V AC: approx. 1.2 VA 360 ... 440 V AC: approx. 1.65 VA
Rated voltages:	20...30/42...48/100...130/187...264/360...440 V AC, 50 or 60 Hz, 10...30/36...80/100...130 V DC
Display:	7 (99999.99 h)
Accuracy:	AC: Supply frequency + 30 ms DC: < 0.003 % (24 h)
Height of figures:	4.5 mm [0.177"]
Colour of figures:	white and red on black
Ambient temperature:	-15° ... +50 °C [5 ... 122 °F]
Mounting position:	any

Protection:	up to IP 51 front side sealing cover K1: IP 54 front side transparent cover Dv U. Dvs: IP 55 (front)
Housing:	Plastic
Weight:	approx. 45 g [1.587 oz]
Options:	Extended temperature range on request
Tin plated round pins	ø1.5 mm [0.059"] with push on connectors Art-No.: 3.205.X01.XXX
Flat pin	0.8 x 3.6 mm [0.032 x 0.142"]
Flat pin	0.8 x 2.8 mm [0.032 x 0.11"] with push on connectors Art-No.: 3.207.X01.XXX
Accessories:	Socket box 945.2 Art-No.: G.008.434 Sealing cover K1 black Art-No.: G.008.301
Front bezel:	F1B black Art-No.: G.007.502
Dummy housing	25 x 50 mm [0.984 x 1.969"] black: Art-No.: T.005.753

### HB 27.00.3

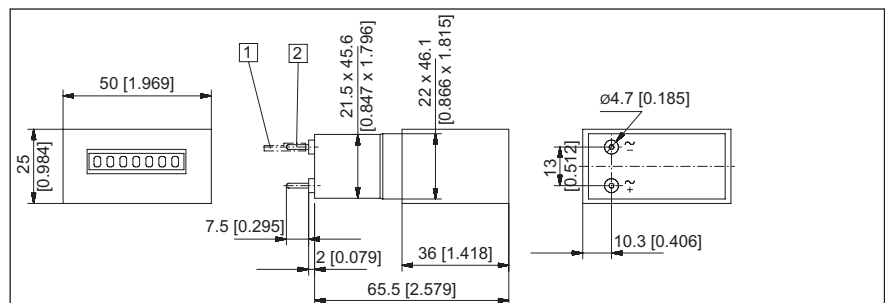

Voltage	Art-No. (AC), 50 Hz	Art-No. (AC), 60 Hz	Art-No. (V DC)
10 ... 30			3.205.001.351*
20 ... 30	3.205.001.071	3.205.001.081	
36 ... 80			3.205.001.353
42 ... 48	3.205.001.072	3.205.001.082	
100 ... 130	3.205.001.074	3.205.001.084	3.205.001.381
187 ... 264	3.205.001.075	3.205.001.085	
360 ... 440	3.205.001.079	3.205.001.089	

- 1 Push-on connector ø 1.5 [0.059"] tin plated  
2 Round pin ø 1.5 [0.059"] tin plated

# Time meter



HB 27.10

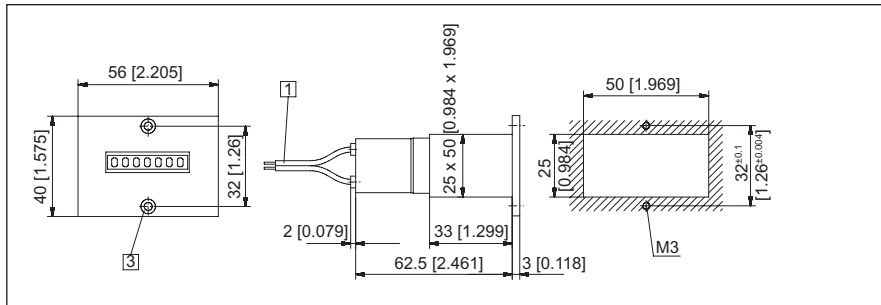

Voltage	Art-No. (AC), 50 Hz	Art-No. (AC), 60 Hz	Art-No. (V DC)
10 ... 30			3.200.101.351
20 ... 30	3.200.101.071	3.200.101.081	
36 ... 80			3.200.101.353
42 ... 48	3.200.101.072	3.200.101.082	
100 ... 130	3.200.101.074	3.200.101.084	3.200.101.381
187 ... 264	3.200.101.075	3.200.101.085	
360 ... 440	3.200.101.079	3.200.101.089	

- 1 Connection cable 2 x 0.5 mm<sup>2</sup> [0.00077 square yards], NYFAZ, 0.5 m [0.547 yard] long
- 3 Countersunk Af3, DIN 74

HB 27.20

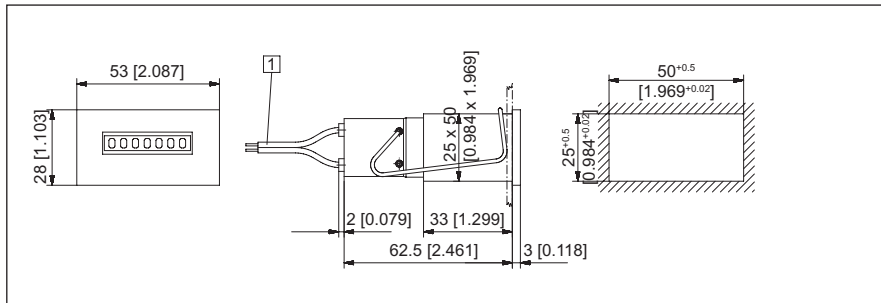

Voltage	Art-No. (AC), 50 Hz	Art-No. (AC), 60 Hz	Art-No. (V DC)
10...30			3.200.201.351*
20...30	3.200.201.071	3.200.201.081	
36...80			3.200.201.353
42...48	3.200.201.072	3.200.201.082	
100...130	3.200.201.074	3.200.201.084	3.200.201.381
187...264	3.200.201.075*	3.200.201.085	
360...440	3.200.201.079	3.200.201.089	

- 1 Connection cable 2 x 0.5 mm<sup>2</sup> [0.00077 square yards], NYFAZ, 0.5 m [0.547 yard] long
- Further stock models:  
3.207.201.075 187 ... 264 V AC  
Flat pins: 0.8 x 2.8 mm

HB 27.30

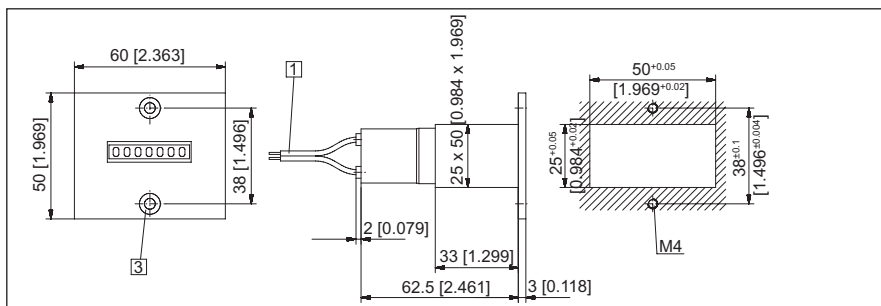

Voltage	Art-No. (AC), 50 Hz	Art-No. (AC), 60 Hz	Art-No. (V DC)
10 ... 30			3.200.301.351
20 ... 30	3.200.301.071	3.200.301.081	
36 ... 80			3.200.301.353
42 ... 48	3.200.301.072	3.200.301.082	
100 ... 130	3.200.301.074	3.200.301.084	3.200.301.381
187 ... 264	3.200.301.075	3.200.301.085	
360 ... 440	3.200.301.079	3.200.301.089	

- 1 Connection cable 2 x 0.5 mm<sup>2</sup> [0.00077 square yards], NYFAZ, 0.5 m [0.547 yard] long
- 3 Countersunk Af3, DIN 74

\*standard stock model



## DIN Hour meter SH 17

- 7-digit hour meter for DIN rail mounting to EN 50022
- 2 modules wide ( 36 mm), Count range 99999.99 h

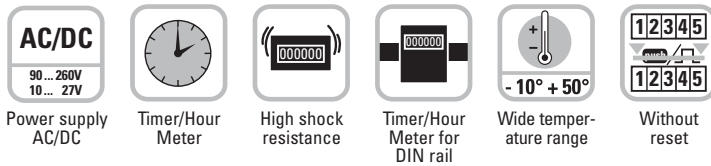

### Versatile

- For voltage ranges  
10...27 V DC, 230 V AC
- Large temperature range
- Protection to IP 65 on the front side
- 2 modules wide
- Without reset,  
therefore tamper-proof



### Accurate

- Quartz for DC version and  
50 Hz for AC version

### Simple

- Simple mounting on 35 mm rail  
to EN 50022
- Snap-on fixing
- 7-digit  
5 digits for hours, 2 digits for minutes  
0.01 h -> 36 s
- High shock and impact resistance
- Simple connection thanks to  
user-friendly screw terminals

### Applications

- General time counting
- Control cabinets
- Small appliances
- Distribution panels
- Plant and equipment etc.

### Technical data:

Electrical connection:	Screw terminal
Power consumption:	DC: approx. 1 W AC: approx. 2.5 VA
Rated voltages:	230 V AC $\pm 10\%$ , 50 Hz 10 ... 27 V DC
On time:	100 %
Display:	7 figures (99999.99 h)
Count mode:	adding
Height of figures:	1.5 x 3.5 mm [0.059 x 0.138"]
Colour of figures:	white on black decimal figures black on white
Reset:	no
Ambient temperature:	-10° ... +70 °C [14 ... 158 °F] at AC (non-condensing) -10° ... +50 °C [14 ... 122 °F] at DC
Mounting position:	any
Protection:	IP 65 front side screw terminal IP 20
Housing:	Plastic; colour Ral 7035
Weight:	approx. 60 g [2.116 oz]
Colour of housing:	grey

### Dimensions:

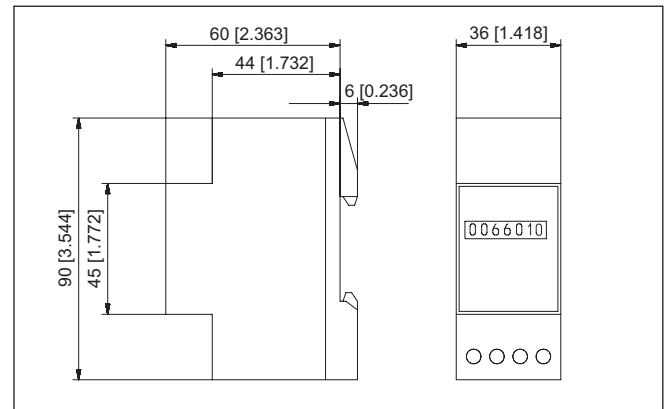

### Connection

- DC: 2 = +  
3 = -
- AC: 2 and 3

### Order code:

Voltage	10 ... 27 V DC	230 V AC
Art. No.	0.170.000.351*	0.170.000.075*

\*standard stock model

## Time meter – Pulse counter HC 77



- **Combination counter consists of hour meter and adding counter in one**
- Without reset
- High shock resistance
- Magnified figures
- Protection IP 52 front side
- Data retention if power is lost
- Long service life
- UL-approval

### Applications:

general counting, service interval for measurement systems (respiratory ventilators, oxygen machines, dialysis machines), small appliances, UV lamps, display panels in cars



### Technical data:

Electrical connection:	Flat pin 0,8 x 6,3 mm [0.032 x 0.248"] with screw terminal tightening torque max. 0,8 Nm
Power consumption:	10 ... 30 V DC: approx. 1 W 36 ... 80 V DC: approx. 1.65 W 100 ... 130 V DC: approx. 1.75 W 20 ... 30 V AC, 50 Hz: approx. 0.53 VA 42...48 V AC , 50 Hz: approx. 0.53 VA 100...130 V AC , 50 Hz: approx. 1.43 VA 187...264 V AC , 50 Hz: approx. 3.0 VA
Rated voltages:	20 ... 30/42 ... 48/100 ... 130/187 ... 264 V AC 50 or 60 Hz, 10 ... 30/36 ... 80/100 ... 130 V DC
On time:	100 %
Count mode:	adding
Height of figures:	4 x 1.7 mm [0.158 x 0.067"]
Colour of figures:	hour: white on black decimal: red on black
Operating indicator of the running time meter:	
AC:	Fast rotating wheel with red dashes: 99999.99 h
DC:	1/100 h display turns continuously by 1 digit in 36 s: 999999.99 h
Accuracy:	AC: Supply frequency + 30 ms DC: < 0.003 % (24 h)
Reset:	no
Ambient temperature:	-15 ... +50 °C [5 ... 122 °F]
Mounting position:	any
Protection:	IP 65 (from front, when built in)
Colour of housing:	black
Weights:	
HC 77	65 g [2.293 oz]
Plug in frame 55	8 g [0.282 oz]

Plug in frame 72	13 g
Options:	<ol style="list-style-type: none"> <li>1. Colour of housing: grey Art-No. 3.55X.400.XXX</li> <li>2. Flat pin 0.8 x 6.3 mm [0.032 x 0.248"] Art-No.: 3.55X.40X.XXX.011</li> <li>3. Separate connections for running time meter and adding counter. This model is available for AC or DC (not mixed) Adding counter max. 10 Imp/s Electrical connections: 2 x cable 2 x 0.5 mm<sup>2</sup> [0.00077 square yards] NYFAZ, 0.5 m [0.547 yard] long (hour meter cable red/black, adding counter grey cable) Art-No. 3.55X.40X.XXX.060</li> <li>4. Sealed window (IP 65 front) with: <ul style="list-style-type: none"> <li>- Screw terminal: Art-No. 3.55X.40X.XXX.419</li> <li>- Flat pin 0.8 x 6.3 mm [0.032 x 0.248"] Art-No. 3.55X.40X.XXX.062</li> <li>- Separated connections (cable) Art-No. 3.55X.40X.XXX.061</li> </ul> </li> </ol>
Approvals:	UL for USA and Canada E128604
Order information:	Art-No. (for special voltages etc. indicate exact model, voltage and frequency e.g. HC 77, 120 V AC, 60 Hz)

Meter with separate connections (rear view)

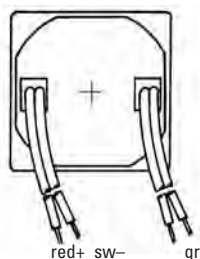

Hour meter

adding counter

## Time meter – Pulse counter HC 77

HC 77

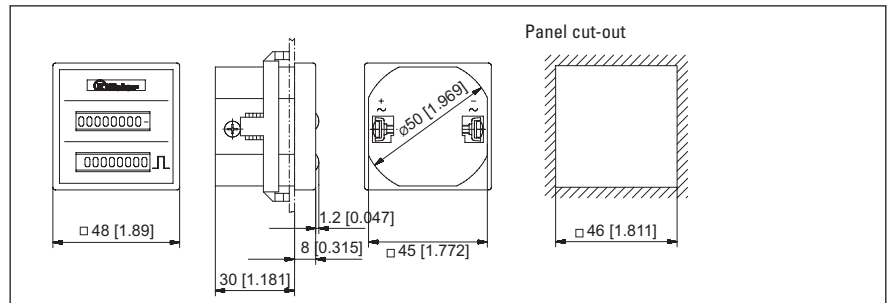

Voltage	Art-No. (AC), 50 Hz	Art-No. (AC), 60 Hz	Art-No. (V DC)
10 ... 30			3.550.401.351
20 ... 30	3.550.401.071	3.550.401.081	
36 ... 80			3.550.401.353
42 ... 48	3.550.401.072	3.550.401.082	
100 ... 130	3.550.401.074	3.550.401.084	3.550.401.381
187 ... 264	3.550.401.075	3.550.401.085	

Colour of housing grey: Art. no. 3.550.400.XXX

HC 77.55

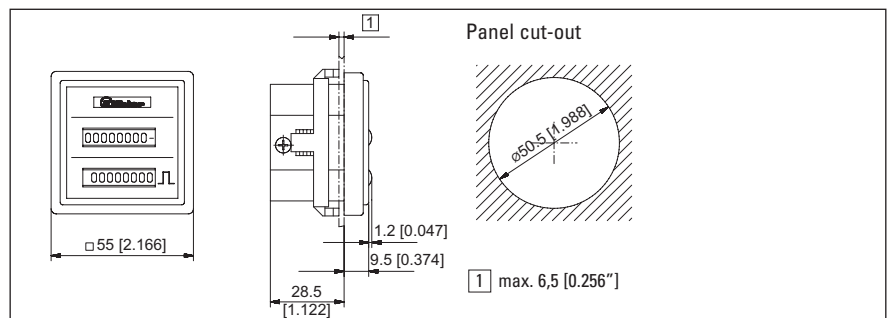

Voltage	Art-No. (AC), 50 Hz	Art-No. (AC), 60 Hz	Art-No. (V DC)
10 ... 30			3.551.401.351
20 ... 30	3.551.401.071	3.551.401.081	
36 ... 80			3.551.401.353
42 ... 48	3.551.401.072	3.551.401.082	
100 ... 130	3.551.401.074	3.551.401.084	3.551.401.381
187 ... 264	3.551.401.075	3.551.401.085	

Colour of housing grey: Art. no. 3.551.400.XXX

HC 77.72

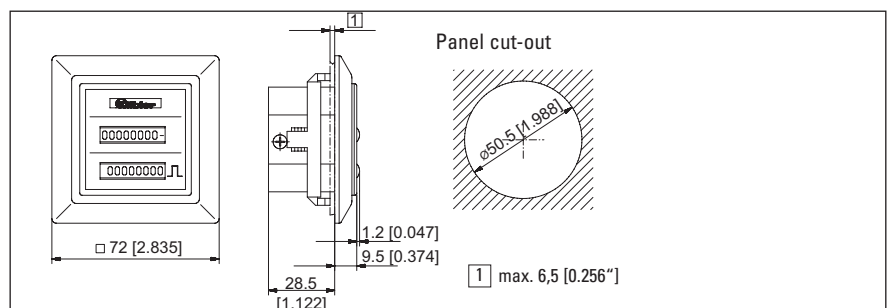

Voltage	Art-No. (AC), 50 Hz	Art-No. (AC), 60 Hz	Art-No. (V DC)
10 ... 30			3.552.201.351
20 ... 30	3.552.401.071	3.552.401.081	
36 ... 80			3.552.201.353
42 ... 48	3.552.401.072	3.552.401.082	
100 ... 130	3.552.401.074	3.552.401.084	3.552.201.381
187 ... 264	3.552.401.075	3.552.401.085	

For panel cut-outs 66 x 66 mm [2.599 x 2.599"] and 68 x 68 mm [2.678 x 2.678"] adapters are available as accessories.  
 Adapter 66 x 66 mm [2.599 x 2.599"]:  
 Art. no. T.009.423  
 Adapter 68 x 68 mm [2.678 x 2.678"]:  
 Art. no. T.009.420

Colour of housing grey: 3.552.400.XXX

## Time meter – Pulse counter HC 77



- **Combination counter consists of time meter and adding counter in one**
- Without reset
- High shock resistance
- Magnified figures
- Protection IP 52 front side
- Data retention if power is lost
- Long service life
- UL-approval

### Applications:

general counting, service interval for measurement systems (respiratory ventilators, oxygen machines, dialysis machines), small appliances, UV lamps, display panels in cars.

### Technical data:

Electrical connection:	SHC 77:	Screw terminal tightening torque max. 0,8 Nm
	SHC 77.60:	2 x cable 2 x 0,5 mm <sup>2</sup> NYFAZ, 0,5 m [0.547 square yards] long Hour meter red/black Adding counter grey
Power consumption:	10 ... 30 V DC:	approx. 1 W
	36 ... 80 V DC:	approx. 1.65 W
	100 ... 130 V DC:	approx. 1.75 W
	20 ... 30 V AC, 50 Hz:	approx. 0.53 VA
	42 ... 48 V AC, 50 Hz:	approx. 0.53 VA
	100 ... 130 V AC, 50 Hz:	approx. 1.43 VA
Rated voltages:	20 ... 30/42 ... 48/100 ... 130/187 ... 264 V AC	
	50 or 60 Hz, 10 ... 30/36 ... 80/100 ... 130 V DC	
	On time:	100 %
	Count mode:	adding
Height of figures:	4 x 1.7 mm [0.158 x 0.067"]	
Colour of figures:	Hour meter:	
	Hours:	white figures on black
	1/10 and 1/100 h:	red figures on black
Operating indicator of the hour meter:	Adding counter:	white figures on black
	AC:	fast rotating wheels with red dashes: 99999.9 h

DC:	1/100 h display turns continuously by 1 digit per 36 s: 999999.9 h	
Accuracy:	AC:	Supply frequency + 30 ms
	DC:	< 0.003 % (24 h)
Reset:	no	
Ambient temperature:	-15 ... +50 °C [5 ... 122 °F]	
Mounting position:	any	
Protection:	IP 52 (from front, when built-in)	
Colour of housing:	black	
Weights:	SHC 77	85 g [2.998 oz]
	SHC 77.60	105 g [3.704 oz]
Options:	SHC 77	The two meters are connected in parallel, this means, that the adding counter registers the total number of events and the time meter the total operating time of the device.
	SHC 77.60	Hour meter and adding counter have two separate connections. This version is available for either AC or DC version (not mixed)
Applications:	switch cabinets, distribution boxes etc.	
Test voltage:	2500V AC, 50 Hz	
Order information:	Art. no. (for special voltages etc. exact type, voltage, frequency e.g. SHC 77, 120 V AC, 60 Hz)	
	Approvals:	UL for USA and Canada E128604

Figure.: SHC 77



SHC 77

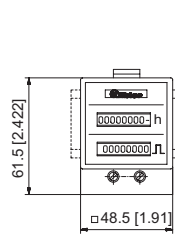

SHC 77.60

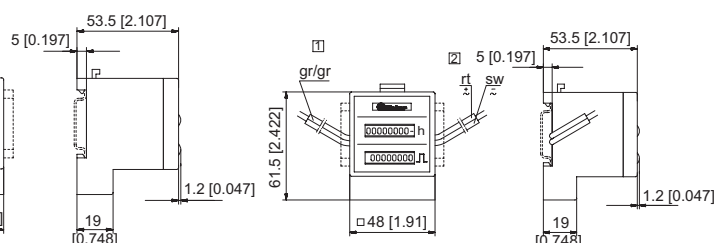

1 Adding counter      2 Hour meter

### SHC 77

Voltage	Art-No. (AC), 50 Hz	Art-No. (AC), 60 Hz	Art-No. (V DC)
10 ... 30			3.553.401.351
20 ... 30	3.553.401.071	3.553.401.081	
36 ... 80			3.553.401.353
42 ... 48	3.553.401.072	3.553.401.082	
100 ... 130	3.553.401.074	3.553.401.084	3.553.401.381
187 ... 264	3.553.401.075	3.553.401.085	

### SHC 77.60 (separate connections)

Voltage	Art-No. (AC), 50 Hz	Art-No. (AC), 60 Hz	Art-No. (V DC)
10 ... 30			3.553.401.351.060
20 ... 30	3.553.401.071.060	3.553.401.081.060	
36 ... 80			3.553.401.353.060
42 ... 48	3.553.401.072.060	3.553.401.082.060	
100 ... 130	3.553.401.074.060	3.553.401.084.060	3.553.401.381.060
187 ... 264	3.553.401.075.060	3.553.401.085.060	

## Energy – Time meter HW 66

115...230V Supply voltage AC	-20° + 55° Temperature	DIN 48 x 48 DIN Front panel	IP 65 High IP value	no reset

Timer	2 x 6 digit	Energy meter



MID approval - pending

### Innovative:

- Metering of hours run and energy consumption in one compact device
- Wide temperature range
- Panel mounting
- Remote readout via SO outputs on request

### Informative:

- Shows both values in parallel
- Can also be read if no voltage present
- 2 x 6-digit easy-to-read display

### Safe and accurate:

- Tamper-proof fixed installation
- High measuring accuracy
- Can be officially calibrated
- High degree of protection

### Technical data:

General	
Supply voltage:	115/230 V AC, -20 % / +15 % 50 or 60 Hz single phase (16 A)
Digits:	2 x 6 digit (single units digit red)
Height of figures (optical):	4 x 1.7 mm
Colour of figures:	white and red, black ground
Temperature range:	-20 to +55 °C
Storage temperature:	-25 to +65 °C
Housing:	DIN panel-mount 48 x 48 mm, depth 55 mm
Protection:	IP 65, DIN 60529 front
Connections:	screw terminals touch-safe max. core cross-section 2.5 mm <sup>2</sup>
Connections SO output:	screw terminals touch-safe max. core cross-section 2.5 mm <sup>2</sup>
LED function:	LED ON, when power supply is connected LED blinks, when energy is being measured

Energy meter	
Accuracy:	Class B (1%), acc. to MID (at 50 Hz version)
Current:	I <sub>max</sub> = 16 A
Current limits:	≥ 20 mA up to 16 A
Start current:	≥ 20 mA
SO output:	1000 pulses per kWh, 5 ... 30 V DC, I <sub>max</sub> = 20 mA
Standard:	EN50470-1, EN50470-3

Hour meter	
Accuracy:	± 2 %
SO output:	10 pulses/h, 5 ... 30 V DC, I <sub>max</sub> = 20 mA

### Applications:

- |                              |                      |
|------------------------------|----------------------|
| Dehumidifiers                | Air-conditioning     |
| Hire equipment and machinery | Production equipment |

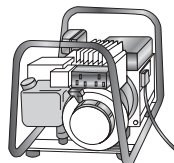
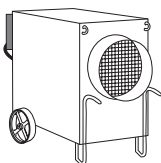

Retro- or standard fitting in dehumidifiers, current generators etc. for the accurate, traceable billing of operating and energy costs

### Order codes:

HW66 230 V AC: 3.563.201.075  
HW66 115 V AC: 3.563.201.074

### Delivery includes:

Counter  
Gasket  
Mounting clip

### Dimensions:

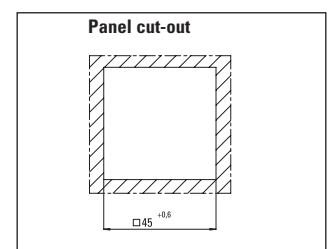
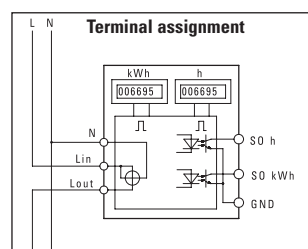
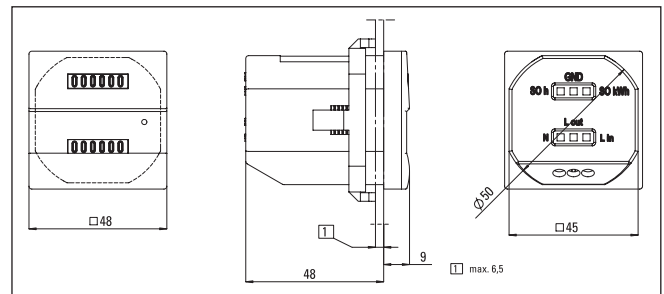

## LCD Hour meter **CODIX 134**



- Low-price and high efficiency
- Large 8-digit LCD display, height of the figures 8 mm [0.315"]
- Optional backlighting of the display
- Various time ranges, hours with minutes or industrial minutes. 1 pulse  $\hat{=}$  36 sec.
- 0.1 second synchronisation makes it suitable for very short activation times
- High voltage versions for 10 ... 260 V AC/DC voltage pulses, can be connected directly via contactors, relays and motors
- Very high accuracy: 100 ppm
- Protection IP65
- Unified Codix design, matching the extensive **CODIX** family
- Screw terminals, RM 5 mm [0.197"]
- Lifetime of the battery approximately 8 years
- Ambient temperature -10 ... +60 °C [14 °F ... 140 °F]
- Locking of the reset key
- Accumulated time always readable thanks to the battery-powered LCD display.

### Technical data

Power supply:	non-replaceable lithium battery: (lifetime approx. 8 years at 20 °C [68 °F])	Time range change (Mode)	
Backlighting:	external electrical source 24 V DC +/-20 %, 50 mA	Contact input:	pOpen Collector (switching at 0 V) NPN: Low: 0 ... 0.7 V, High: 3 ... 5 V DC
Display:	LCD, 8 digits, height of the figures 8 mm [0.315"]	Time range:	depending on the circuit (see order information)
Counting direction:	adding	Reset Input (only DC and high voltage)	
Display range:	see next page	Minimum pulse time:	DC: 50 ms, high voltage: 16 ms
Reset :	manual and electrical	Contact input DC:	NPN: Low: 0 ... 0.7 V, High: 3 ... 30 V DC
Timer inputs DC versions:	(max. 30 V DC)	High voltage input:	10 ... 260 V DC/V AC
Timer input	NPN or PNP depending on the type (see table)	Reset locking input (for DC and AC)	
Switching level:	NPN: Low: 0 ... 0.7 V, High: 3 ... 30 V DC PNP: Low: 0 ... 0.7 V, High: 4 ... 30 V DC	Electrical reset key locking	
Counting start:	NPN: for low signal at the timer input PNP: for high signal at the timer input	Input not active:	reset key locked
Timer inputs high voltage version (10 ... 260 V DC/V AC)		Contact input:	Open Collector NPN (switching at 0 V)
Timer input:	optocoupler input, max. 30 V	Switching level:	NPN: Low: 0 ... 0.7 V, High: 3 ... 5 V DC
Min. pulse time:	16 ms	Interference emissions:	EN 55011 Class B, EN 61000-6-2 EN 61010 Section 1 (only AC versions)
Switching level:	low: 0 ... 2 V DC/V AC, high: 10 ... 260 V DC/V AC	Housing:	dark grey RAL 7021
Counting start:	for high signal at the timer input	Operating temperature:	-10 ... +55 °C [14 ... 131 °F]
		Ambient temperature:	-10 ... +60 °C [14 ... 140 °F]
		Storage temperature:	-20 ... +70 °C [-4 ... 158 °F]
		Protection:	IP 65 front side
		Weight:	approx. 50 g [1.764 oz]

### Connecting diagram:

**DC type:**  
6.134.012.8x0

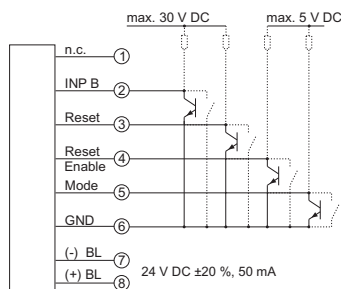

**DC type:**  
6.134.012.8x1

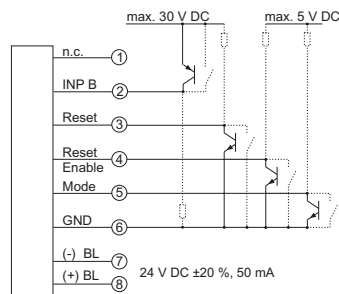

**AC type:**  
6.134.012.8x3

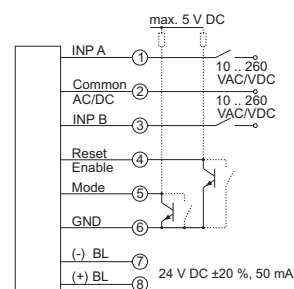

BL = backlighting

### Dimensions:

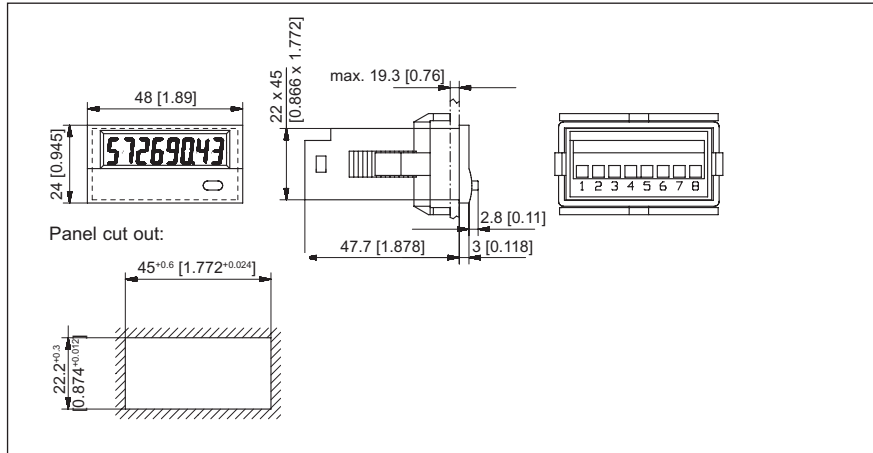

### Display:

#### Time ranges and display

Time range	Display
99999 h 59 m	
99999.99 h	

### Bezel dimensions:

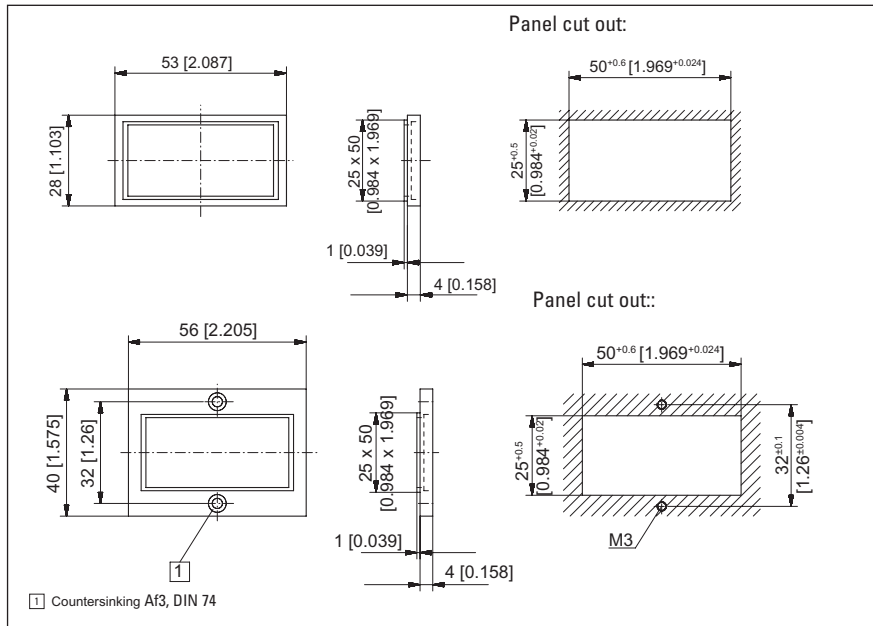

### Delivery specification:

- Digital display
- Panel mounting clip
- Bezel for screw mounting, panel cut out 50 x 25 mm [1.969 x 0.984]
- Bezel for clip mounting, panel cut out 50 x 25 mm [1.969 x 0.984]
- Gasket
- Operating instructions.

### Order code:

Type	Mode	Time range	Inputs	INP A	INP B	
6.134.012.8x0*	Timer	99999h 59 m/	-		0 ... 0,7 V DC	NPN
6.134.012.8x1*	Timer	99999.99 h			4 ... 30 V DC	PNP
6.134.012.8x3*	Timer		10 ... 260 V AC/DC	AC/DC	10 ... 260 V AC/DC	AC/D

X: 5 = without backlighting  
X: 6 = with backlighting

\* standard stock model

## LCD Hour meter **CODIX 135**



- Low-price and high efficiency
- Large 8-digit LCD display, height of the figures 8 mm [0.315"]
- Optional backlighting of the display
- Various time ranges from 0.1 second to 100,000 hours
- 0.1 second synchronisation makes it suitable for very short activation times
- High voltage versions for 10 ... 260 V AC/DC voltage pulses, can be connected directly via contactors, relays and motors
- Very high accuracy: 100 ppm
- Protection IP65
- Unified Codix design, matching the extensive **CODIX** family
- Screw terminals, RM 5 mm [0.197"]
- Lifetime of the battery approximately 8 years
- Ambient temperature -10 ... +60 °C [14 ... 140 °F]
- Locking of the reset key
- Accumulated time always readable thanks to battery powered LCD display

### Technical data

Power supply:	non-replaceable lithium battery: (lifetime approx. 8 years at 20 °C [68 °F])	Time range change (Mode)	
Backlighting:	external electrical source 24 V DC +/-20 %, 50 mA	Contact input:	Open Collector (switching at 0 V) NPN: Low: 0 ... 0.7 V, High: 3 ... 5 V DC
Display:	LCD, 8 digits, height of the figures 8 mm [0.315"]	Time range:	depending on the circuit (see order information)
Counting direction:	adding	Reset Input (only DC and high voltage)	
Display range:	see next page	Minimum pulse time:	DC: 50 ms, high voltage: 16 ms
Reset:	manual and electrical	Contact input DC:	NPN: Low: 0 ... 0.7 V, High: 3 ... 30 V DC
Timer inputs DC versions: (max. 30 V DC)		High voltage input:	10 ... 260 V DC/V AC
Timer input	NPN or PNP depending on the type (see table)	Reset locking input (for DC and AC)	
Switching level:	NPN: Low: 0 ... 0.7 V, High: 3 ... 30 V DC PNP: Low: 0 ... 0.7 V, High: 4 ... 30 V DC	Electrical reset key locking	
Counting start:	NPN: for low signal at the timer input PNP: for high signal at the timer input	Input not active:	Reset key locked
Timer inputs high voltage version (10 ... 260 V DC/V AC)		Contact input:	Open Collector NPN (switching at 0 V)
Timer input:	Optocoupler input, max. 30 Hz	Switching level:	NPN: Low: 0 ... 0.7 V, High: 3 ... 5 V DC
Min. pulse time:	16 ms	Interference emissions:	EN 55011 Class B, EN 61000-6-2 EN 61010 Section 1 (only AC versions)
Switching level:	Low: 0 ... 2 V DC/V AC, High: 10 ... 260 V DC/V AC	Housing:	dark grey RAL 7021
Counting start:	for high signal at the timer input	Operating temperature:	-10 ... +55 °C [14 ... 131 °F]
		Ambient temperature:	-10 ... +60 °C [14 ... 140 °F]
		Storage temperature:	-20 ... +70 °C [-4 ... 158 °F]
		Protection:	IP 65 front side
		Weight:	approx. 50 g [1.764 oz]

### Connecting diagram:

**DC type:**  
6.135.012.8x0

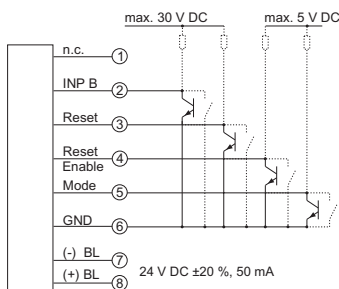

**DC type:**  
6.135.012.8x1

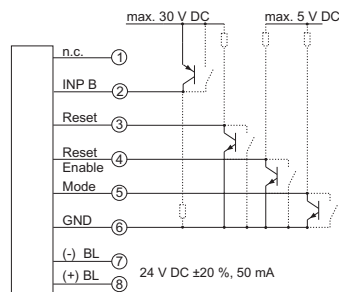

**AC type:**  
6.135.012.8x3

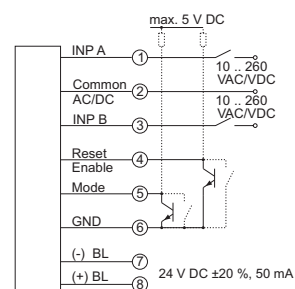

BL = backlighting



### Dimensions:

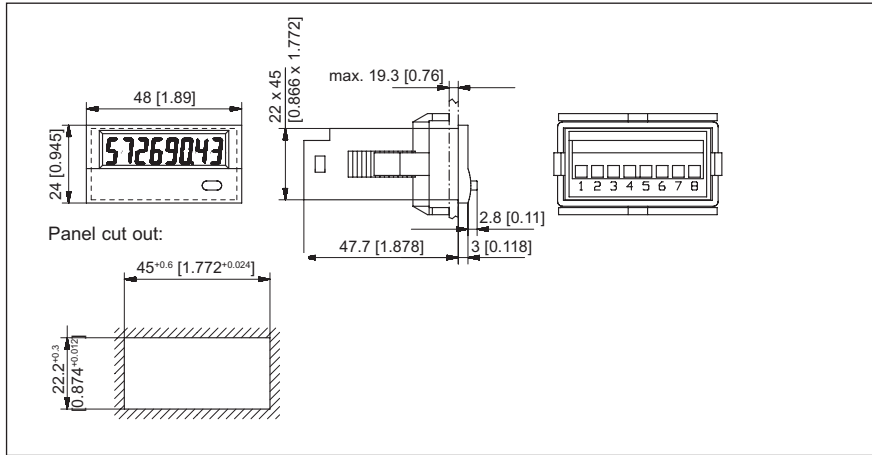

### Display:

#### Time ranges and display

Time range	Display
9999h 59m 59 s	
9999999.9 s	

### Frame dimensions:

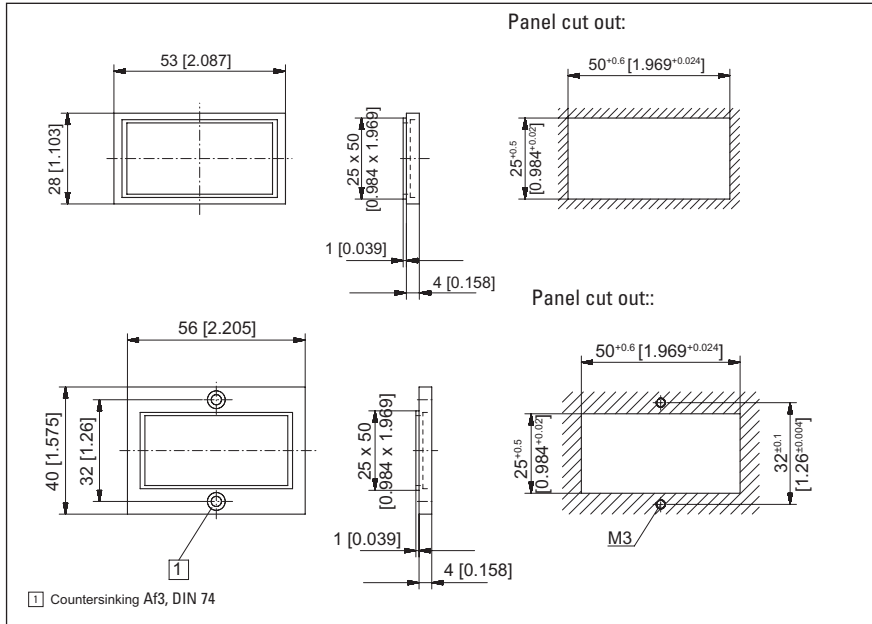

### Delivery specification:

- Digital display
- Panel mounting clip
- Bezel for screw mounting, panel cut out 50 x 25 mm [1.969 x 0.984]
- Bezel for clip mounting, panel cut out 50 x 25 mm [1.969 x 0.984]
- Gasket
- Operating instructions.

### Order code:

Type	Mode	Time range	Inputs		
			INP A	INP B	
6.135.012.8x0*	Timer	9999 h 59 m 59 s / 9999999.9 s	-	0 ... 0,7 V DC	NPN
6.135.012.8x1*				4 ... 30 V DC	PNP
6.135.012.8x3*			10 ... 260 V AC/DC	AC/DC	10 ... 260 V AC/DC

X: 5 = without backlighting  
X: 6 = with backlighting

\* standard stock model

## LCD Hour Meter Module 194



- 6-digit display, 6 mm [0.236"] height
- Time range 9999-99 hours
- Wide operating voltage and temperature range
- High reliability
- Low cost and small size
- Low operating current
- Very high shock and vibration specs
- Non-volatile memory (no battery)

### Technical features for LCD Hour Meter Module Type 194

Supply:	1. 4.75 ... 15 V DC 2. 9 ... 60 V DC reverse polarity protection	Working temperature:	-40 ... + 80 °C [-40 ... 176 °F]
Current consumption:	1. 8 mA at 4.75 ... 15 V DC 2. 6 mA at 9 ... 60 V DC	Operating temperature:	-40 ... + 85 °C [-40 ... 158 °F]
Reset input:	high 4 ... 60 V DC; low: 0 ... 0.7 V DC pulse length min. 1 ms edge triggered	Storage temperature:	-50 ... + 90 °C [-58 ... 194 °F]
Display:	7-digit display, figure height 6 mm [0.236"]	Interference emission:	EN 61 000-6-3, EN 55 011, class B
Data backup:	EEPROM	Interference resistance:	EN 61 000-6-2
Housing:	dimension 18 x 33 mm [0.709 x 1.299"]	Weight:	approx. 8 g [0.282 oz]
Colour:	black	Memory capacity:	CMOS EEPROM. non-volatile memory has data retention in excess of 10 years
Display:	9999-99 hours	Shock resistance acc. to DIN-IEC 68-2-27:	550 m/s <sup>2</sup> , 11 ms
Measuring error:	max. 4 s	Vibration resistance acc. to DIN-IEC 68-2-6:	50 ... 200 m/s <sup>2</sup> , 10 ... 80 Hz
Measuring error of the quartz clock:	max. 200 ppm (25 °C) [77 °F]	Needs protection from:	inductive stress peaks, high energy noise, fields switching, alternator load dump

### Dimensions:

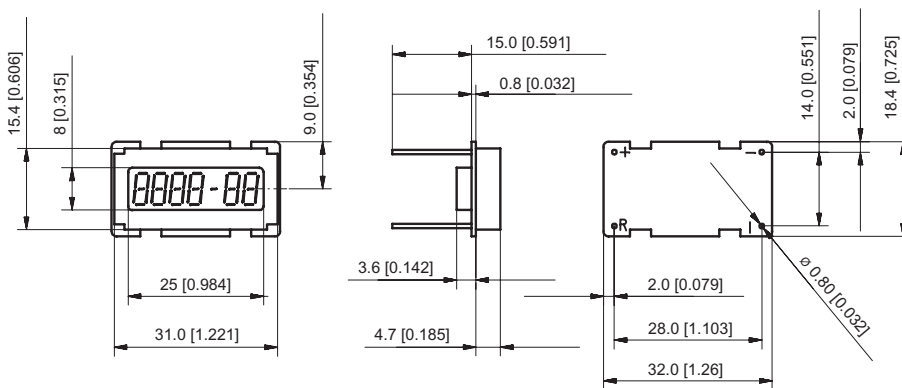

### Connecting diagram:

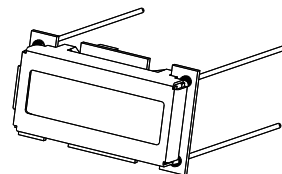
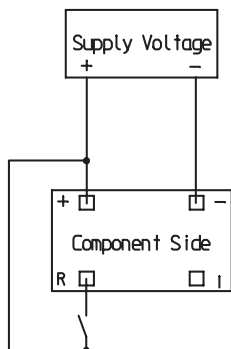

### Order code:

LCD Hour Meter Module Type 194:  
 4.5 ... 15 V DC: Order-No.: 6.194.012.F00  
 Art-No.: 162 137  
 9 ... 60 V DC: Order-No.: 6.194.012.G00  
 Art. no.: 162 138

### Delivery specification:

- LCD Hour Meter Module Type 194  
 - Operating instructions

## LCD Hour Meter Module 198



- Non-volatile memory (no battery)
- High reliability
- Low cost and small size
- Low operating current
- Wide operating voltage and temperature range
- Very high shock and vibration specs
- Solid state electronics

### Technical features for LCD Hour Meter Module Type 198

Supply:	4.5 ... 28 V DC	EMC:	according to EC EMC directive 89/36/EWG
Current consumption:	3 mA maximum at 8 ... 24 V DC 10 mA at 28 V DC	Emitted interference:	EN 50081-2/EN 55011 Class B
Start and reset input:	8 ... 28 V DC	Immunity to interference:	EN 6100-6-2
Display:	6-digit display, figure height 8 mm [0.315"]	Weight:	approx. 8 g [0.282 oz]
Data backup:	EEPROM	Memory capacity:	CMOS EEPROM. non-volatile memory has data retention in excess of 10 years without power.
Housing:	dimension 15 x 33 mm [0.591 x 1.299"]	Protection from:	inductive switching, alternator load dump
Colour:	black		
Operating temperature:	-40 ... +85 °C [-40 ... 185 °F]		
Humidity:	95 % RH +32 C for 2 hours		

### Dimensions:

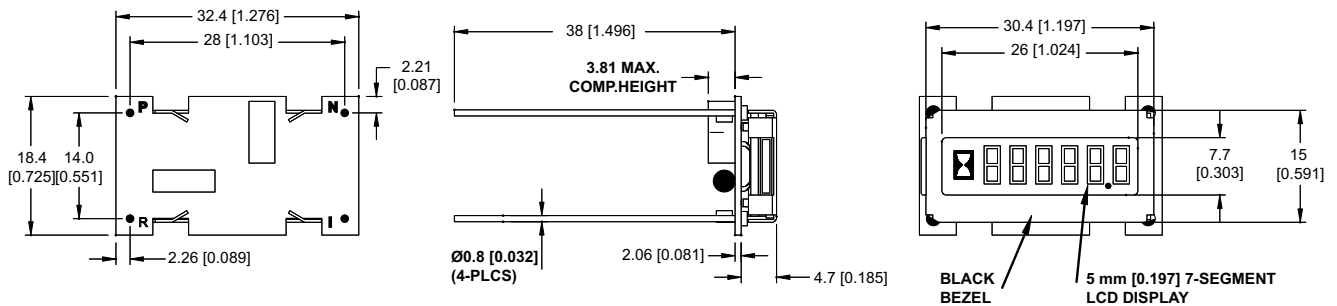

### Connecting diagram:

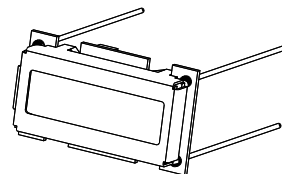
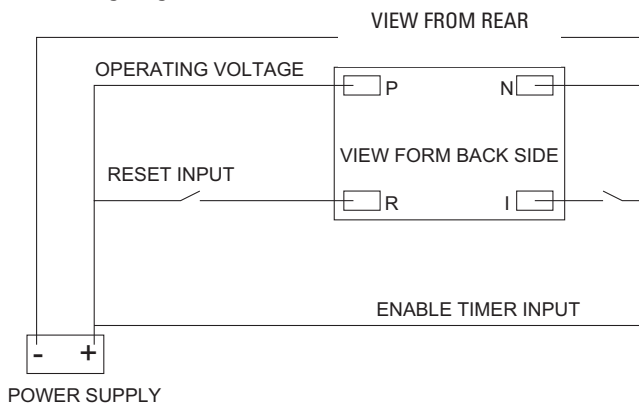

**Order code:**  
LCD Hour Meter Module Type 198:  
Order-No.: 6.198.012.300\*

**Delivery specification:**  
– LCD Hour Meter Module Type 198  
– Operating instructions  
\*standard stock model

## Time and hour meter, short time meter **CODIX 523**

- Pulse width measurement (operating time)
- Time interval measurement (start/stop)

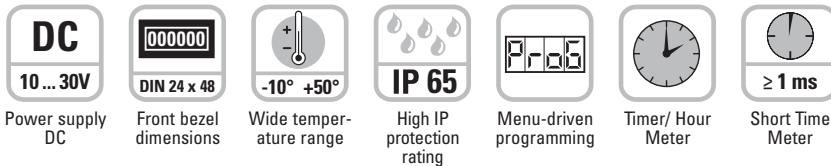

### Powerful

- **High accuracy**  
Thanks to quartz time base
- **Robust housing**  
IP 65 protection
- **LED display**  
Very bright, 8 mm high
- **Time base can be set individually**  
Hours, minutes or seconds – can be set even more precisely thanks to the max. 3 decimal places. Smallest attainable resolution: milliseconds
- **Fast start-up time**  
Detects incoming pulses just 16 ms after being switched on – so no pulses are lost with a simultaneous motor start-up



### User-friendly

- **Big keys**  
Pressing either of the keys switches between displays  
Can also be operated when using gloves
- **Easy to programme**  
Easy menu-driven programming and operation  
Possibility to enter the programming mode during operation, with authentication query

### Universal

- **Individually programmable start/stop function**  
By means of 2 start/stop inputs, up to 4 different measuring principles can be achieved, e.g. active or passive pulse width measurement, time interval measurement with one input or with separate inputs
- **Manual or electrical reset**  
Tamper-proof, due to lockable reset function
- **User-programmable setpoint**  
Start time at which the time counting should begin
- **DC power supply**  
With sensor power supply
- **Inputs**  
As an alternative to the HTL inputs, devices with a 5 VDC input trigger level are available, for use as parallel displays for PLCs
- **Optional output**  
1 Hz clock pulse for active time measurement

### Applications for time and hour meters, short-time meters

- Time measurements such as hours run recording on all machines and plant, e.g. compressors, solariums, special lights and lamps
- Accessories, OEM equipment or retrofitting to production machine
- Measurement of short times on processes and procedures, time recording (stop-watch function) at sporting events
- Hours run recording for motor vehicles and time monitoring for rally vehicles

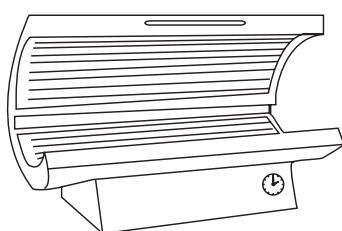

Hours run of UV lamps

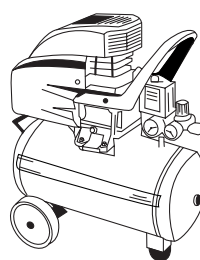

Operating hours

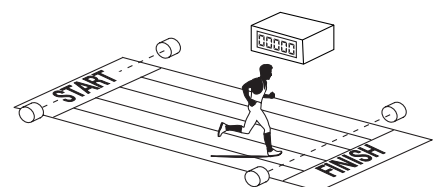

Short time measurement > 1 ms

# Time meter electronic

## Time and Hour Meter, Short Time Meter **CODIX 523**

### Technical data:

Supply voltage:	10 ... 30 V DC, with reverse polarity protection	Level of inputs:	Low: 0 ... 0.2 x U <sub>B</sub> High: 0.6 x U <sub>B</sub> ... 30 V DC
Current consumption:	max. 50 mA	Optocoupler output:	Max. 30 V, 10 mA
Display:	6-digit 7-segment red LED; 8 mm [0.315"] high	Accuracy:	<50 ppm
Data backup:	EEPROM	Ambient temperature:	-10 ... +50 °C [14 ... 122 °F]
Housing:	Dimension 48 x 24 mm [1.89 x 0.945"] according to DIN 43 700; RAL 7021, grey	Storage temperature:	-25 ... +70 °C [-13 ... 158 °F]
Polarity of Inputs:	programmable, npn or pnp for all inputs	EMC:	according to EC EMC directive 89/36/EWG
Input resistance:	approx. 5 kΩ	Emitted interference:	EN 61 0006-4/EN 55011 class B
Resolution:	up to 0.001 s	Immunity to interference:	EN 61000-6-2
Reset time:	5 ms	Protection:	IP65 front side
		Weight:	approx. 50 g [1.764 oz]

### Block diagram:

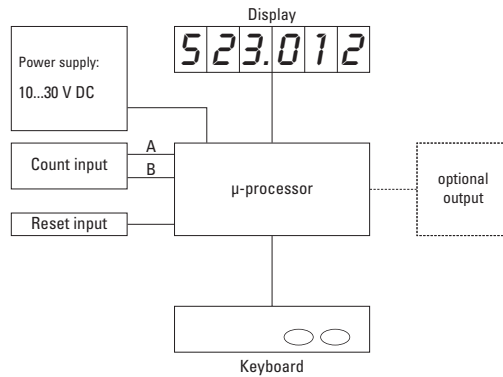

### Dimensions:

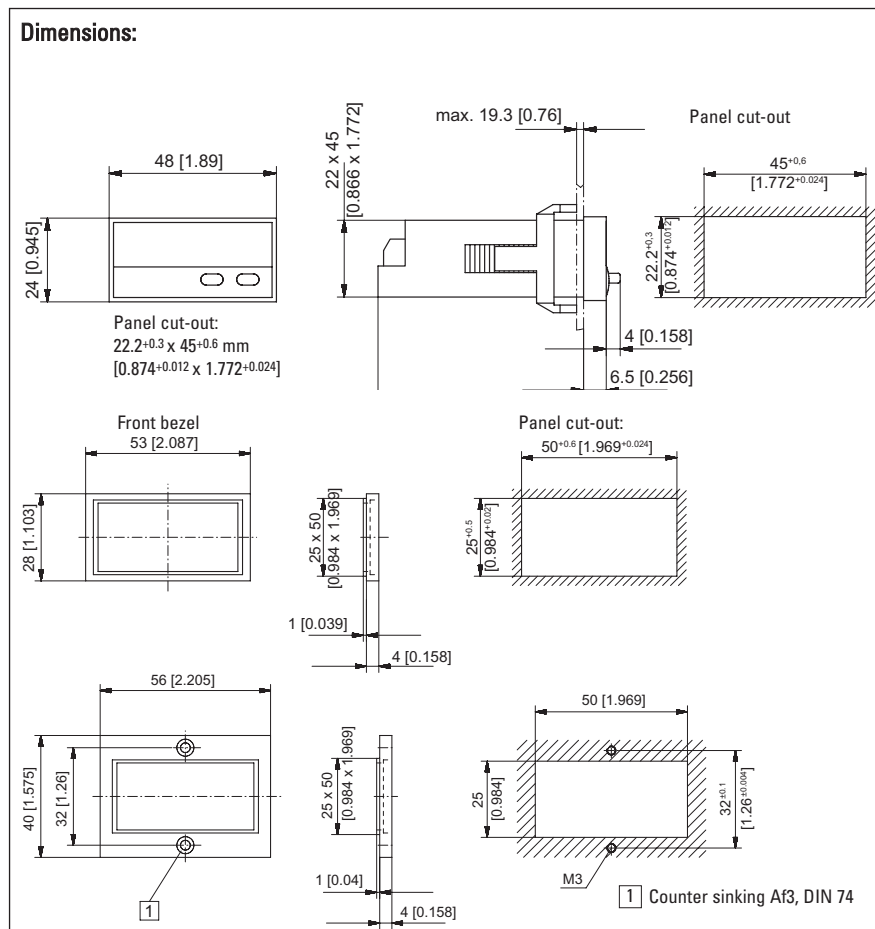

### Connections:

without optocoupler

- 1 10 ... 30 VDC
- 2 0 V GND
- 3 INP A
- 4 INP B
- 5 Reset

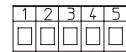

### Connections:

with optocoupler (npn)

- 1 10 ... 30 VDC
- 2 0 V GND
- 3 INP A
- 4 INP B
- 5 Reset
- 6 Emitter
- 7 Collector

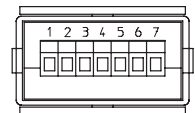

### Delivery specification:

- 1 Digital display
- 1 Panel mounting clip
- 1 Bezel for screw mounting, panel cut out 50 x 25 mm [1.969 x 0.984"]
- 1 Bezel for clip mounting, panel cut out 50 x 25 mm [1.969 x 0.984"]
- 1 Seal
- 1 Multilingual operating instructions

### Order code:

6.523.01X.3X0

- Input switch level
- 0 = Standard\*
- A = 5 V
- Output
- 1 = Optocoupler
- 2 = No output\*

\* Standard stock model

## Multifunction display **CODIX 524**

programmable as:

- Pulse counter
- Position display
- Frequency / speed display
- Timer/ short time meter

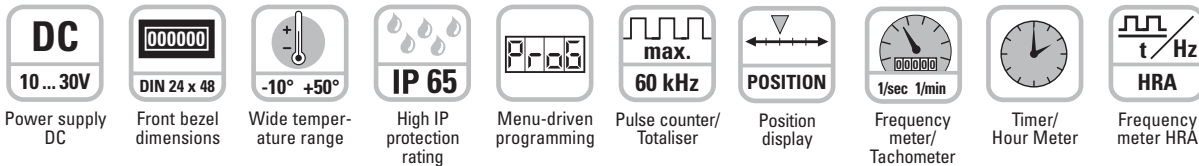

### Powerful

- **Fast count input**  
Input frequency max. 60 kHz
- **Robust housing**  
IP 65 protection
- **LED display**  
Very bright, 8 mm high
- **HRA – High Rate Accuracy System**  
Frequencies up to 38 Hz are calculated using time-interval (period duration) measurement.  
Frequencies > 38 Hz are calculated using a special time base (gate time) measurement. A very high accuracy of > 0.1% is achieved, even with very short gate times. The resulting measurement is available after a max. of 50 ms.
- **Fast start-up time**  
Detects incoming pulses just 16 ms after being switched on – so no pulses are lost with a simultaneous motor start-up



### User-friendly

- **Big keys**  
Can also be operated when using gloves
- **Easy to programme**  
Easy menu-driven programming and operation  
Possibility to enter the programming mode during operation, with authentication query

### Universal

- **Individually programmable scaling**  
Multiplication and division factor (0.0001 to 99.9999), to display corresponding engineering units, e.g. position in 1/10 mm and speed in RPM
- **4 different count input modes**  
2-channel input for detecting count direction, difference or adding mode, quadrature x1, x2 or x4
- **Frequency measurement**  
Display in 1/min or 1/sec
- **Time counting**  
Pulse width or time interval measurement in hours, minutes or seconds, as well as real-time display
- **DC power supply**
- **Inputs**  
As an alternative to the HTL inputs, devices with a 5 VDC input trigger level are available, for use as parallel displays for PLCs
- **Optional output**  
Zero signal for position and count, zero-speed monitoring, 1 Hz clock pulse for active time measurement

### Applications for Multi-function Display

- Counting tasks such as quantity and piece counting, measuring and recording of speed and of operating and processing times
- Piece counting or tool-life measurement on die cutters, presses, extruders, wood-working machines, drilling machines, pick-and-place machines, guillotines, special-purpose vehicles etc.
- Positioning tasks on processing machines, such as sawing machines, milling machines, bending and folding machines, etc.
- Production data acquisition by means of piece counting (using difference or adding), or measurement of production times or production speeds
- Totalizing flow, quantity and other scaleable media, or display of current flow rates

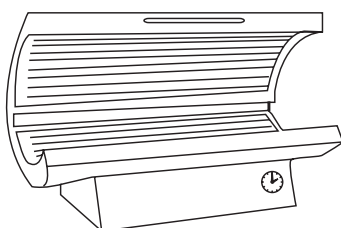

Hours run of UV lamps

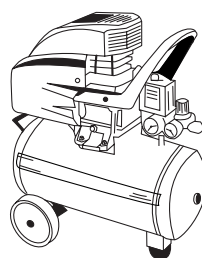

Operating hours

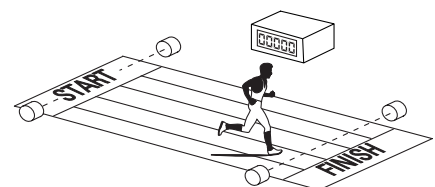

Short time measurement > 1 ms

# Time meter electronic

## Multifunction display *CODIX 524*

### Technical data:

Supply voltage:	10 ... 30 V DC, with reverse polarity protection	Level of inputs:	Low: 0 ... 0.2 x U <sub>B</sub> [V DC] High: 0.6 x U <sub>B</sub> ... 30 V DC
Current consumption:	max. 50 mA	Level of inputs: 5 V version	Low: 0 ... 2 V DC High: 4 ... 30 V DC
Display:	6 digit red 7-segment LED; 8 mm [0.315"] high	Optocoupler output:	Max. 30 V, 10 mA
Data backup:	EEPROM	Accuracy:	tachometer: <0.1 % timer: 50 ppm
Housing:	dimension 48 x 24 mm [1.89 x 0.945"] according to DIN 43 700; RAL 7021, grey	EMC:	according to EC EMC directive 89/36/EWG
Polarity of inputs:	programmable, npn or pnp for all inputs	Immunity to interference:	EN 61000-6-4/EN 55011 class B
Input resistance:	approx. 5 kΩ	Emitted interference:	EN 61000-6-2
Counting frequency:	60 kHz, can be damped to 30 Hz	Ambient temperature:	-10 ... +50 °C [14 ... 122 °F]
Display range timer:	0.001 s ... 999999 h	Storage temperature:	-25 ... +70 °C [-13 ... 158 °F]
Reset time:	5 ms	Protection:	IP 65 front side
		Weight:	approx. 50 g [1.764 oz]

### Block diagram:

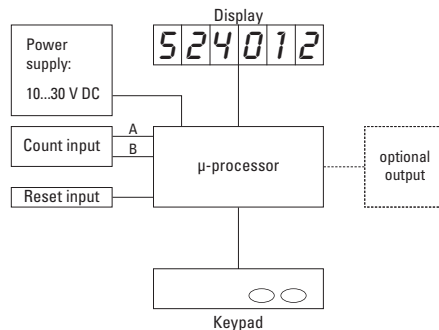

### Dimensions:

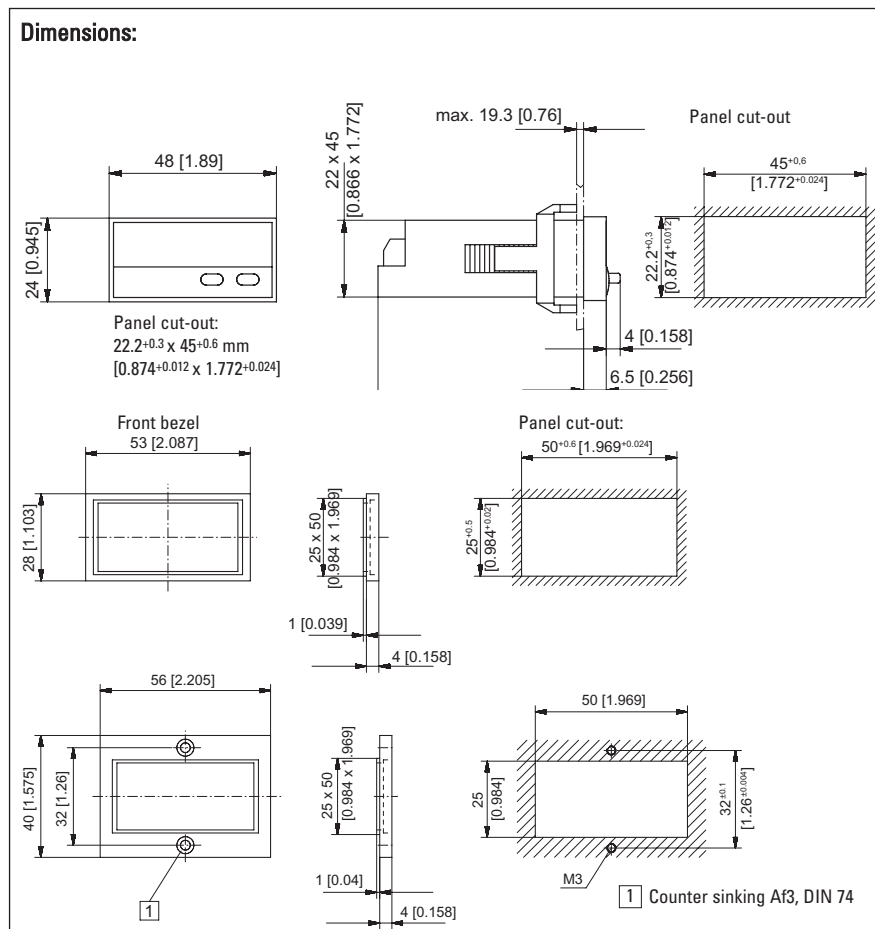

### Connections:

without optocoupler

- 1 10 ... 30 V DC
- 2 0 V GND
- 3 INP A
- 4 INP B
- 5 Reset

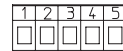

### Connections:

with optocoupler

- 1 10 ... 30 V DC
- 2 0 V GND
- 3 INP A
- 4 INP B
- 5 RESET
- 6 Emitter
- 7 Collector

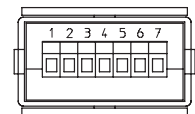

### Delivery specifications:

- 1 Digital display
- 1 Panel mounting clip
- 1 Bezel for screw mounting, panel cut out 50 x 25 mm [1.969 x 0.984"]
- 1 Bezel for clip mounting, panel cut out 50 x 25 mm [1.969 x 0.984"]
- 1 Seal
- 1 Multilingual operating instructions

### Order code:

6.524.01X.3X0

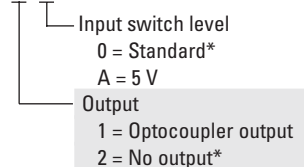

\* standard stock model

## Universal with dual functions **CODIX 52U**

**4 dual functions in one device**  
 > solves all applications where 2 different values must be displayed simultaneously.

- Counter with 2 totalizing ranges
- Totaliser and time counter
- Totaliser and frequency counter
- Timer with 2 time ranges

10 ... 30V	DIN 24 x 48	-10° +50°	IP 65	Menu-driven programming	max. 60 kHz	1/sec 1/min	Timer/ Hour Meter	t / Hz HRA
Power supply DC	Front bezel dimensions	Wide temperature range	High IP protection rating		Pulse counter/ Totaliser	Frequency meter/ Tachometer		Frequency meter HRA

### Powerful

- **Fast count input**  
Input frequency max. 60 kHz
- **Robust housing**  
IP 65 protection
- **LED display**  
Very bright, 8 mm high
- **HRA – High Rate Accuracy System**  
Frequencies up to 38 Hz are calculated using time-interval (period duration) measurement.  
Frequencies > 38 Hz are calculated using a special time base (gate time) measurement. A very high accuracy of > 0.1% is achieved, even with very short gate times. The resulting measurement is available after a max. of 50 ms.
- **Fast start-up time**  
Detects incoming pulses just 16 ms after being switched on – so no pulses are lost with a simultaneous motor start-up



### User-friendly

- **Big keys**  
Can also be operated when using gloves
- **Easy to programme**  
Easy menu-driven programming and operation  
Possibility to enter the programming mode during operation, with authentication query  
Pressing the right key switches between displays

### Universal

- **Individually programmable scaling**  
Multiplication and division factor (0.0001 to 99.9999), to display corresponding engineering units, e.g. position in 1/10 mm and speed in RPM
- **Separate factors for frequency- and pulse counting**
- **DC power supply**
- **Inputs**  
As an alternative to the HTL inputs, devices with a 5 VDC input trigger level are available, for use as parallel displays for PLCs
- **Timer specials**  
Timer or hours-run meter with various Start Stop measurements, time range settings in hours, minutes or seconds, with decimal point. Resolutions up to 1/1000 can be programmed

### Applications for dual functions

- **Pulse and frequency (speed)**  
e.g. production data acquisition: total piece count and speed on OEM equipment, flow rate measuring systems – total flow and current flow
- **2 pulse counters**  
Measurement of batch and total piece count or of daily production count and total count values

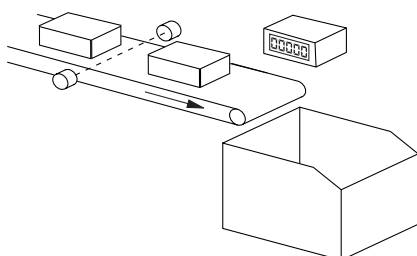

Piece count on conveyor and production speed

- **Pulse and time (Maintenance counter)**  
Used in the lift industry as trip counters and hours-run meters and on production machines for piece and time counting, flow and time measurement, materials handling time and quantities

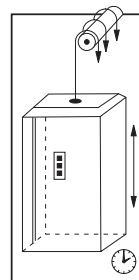

Trip counter and hours-run

- **2 timers**  
Measurement of total time and order-specific times, maintenance intervals and total time, time of day and total time.

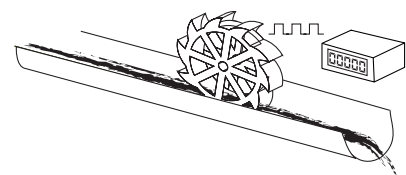

Flow rate and total volume



## Universal with dual functions **CODIX 52U**

### Technical data:

Supply voltage:	10 ... 30 V DC, with reverse polarity protection	Level of inputs:	Low: 0 ... 0.2 x U <sub>B</sub> [V DC] High: 0.6 x U <sub>B</sub> ... 30 V DC
Current consumption:	max. 40 mA	Level of inputs:	Low: 0 ... 2 V DC High: 4 ... 30 V DC
Display:	6-digit red 7-segment LED; 8 mm [0.315"] high	5 V version	High: 4 ... 30 V DC
Data backup:	EEPROM	Optocoupler output:	Max. 30 V, 10 mA
Housing:	dimension 48 x 24 mm [1.89 x 0.945"] according to DIN 43 700; RAL 7021, grey	Accuracy:	<0.1 % (Frequency display, tachometer)
Polarity of inputs:	programmable, npn or pnp for all inputs	EMC:	according to EC EMC directive 89/36/EWG
Input resistance:	approx. 5 kΩ	Immunity to interference:	EN 61000-6-4/EN 55011 class B
Display range:	0.001 s ... 999999 h	Emitted interference:	EN 61000-6-2
Reset time:	5 ms	Ambient temperature:	-10 ... +50 °C [14 ... 122 °F]
		Storage temperature:	-25 ... +70 °C [-13 ... 158 °F]
		Protection:	IP 65 front side
		Weight:	approx. 50 g [1.764 oz]

### Block diagram:

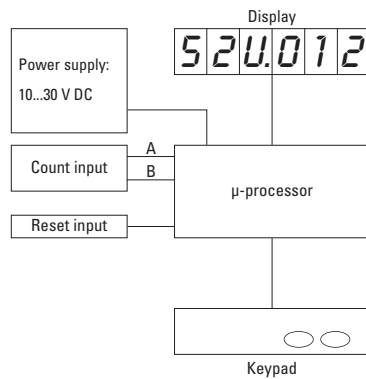

### Dimensions:

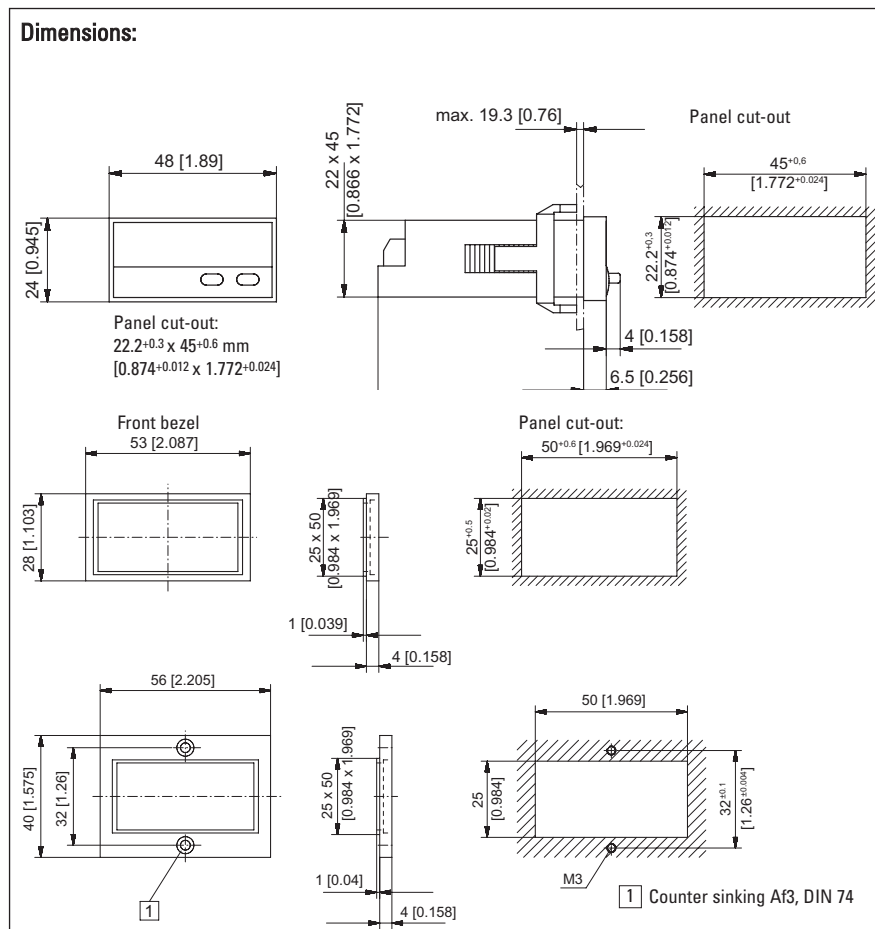

### Connections:

without optocoupler

- 1 10 ... 30 V DC
- 2 0 V GND
- 3 INP A
- 4 INP B
- 5 Reset

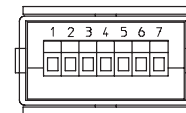
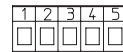

### Delivery specifications:

- 1 Digital display
- 1 Panel mounting clip
- 1 Bezel for screw mounting, panel cut out  
50 x 25 mm [ 1.969 x 0.984"]
- 1 Bezel for clip mounting, panel cut out  
50 x 25 mm [1.969 x 0.984"]
- 1 Seal
- 1 Multilingual operating instructions

### Order code:

6.52U.012.3X0

Input switch level  
0 = Standard\*  
A = 5 V

\* standard stock model

## Time meter and short time meter **CODIX 543**

- Pulse width measurement (operating time)
- Time interval measurement (start/stop)

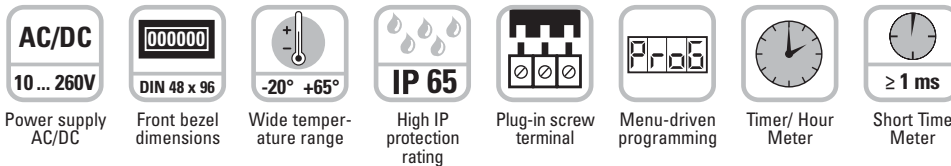

### Powerful

- **High accuracy**  
Thanks to quartz time base
- **Robust housing**  
IP 65 protection
- **LED display**  
Very bright, 14 mm high
- **Time base can be set individually**  
Hours, minutes or seconds – can be set even more precisely thanks to the max. 3 decimal places. Smallest attainable resolution: milliseconds
- **Fast start-up time**  
Detects incoming pulses just 16 ms after being switched on – so no pulses are lost with a simultaneous motor start-up



### User-friendly

- **Big keys**  
Pressing either of the keys switches between displays  
Can also be operated when using gloves
- **Easy to programme**  
Easy menu-driven programming and operation  
Possibility to enter the programming mode during operation, with authentication query

### Universal

- **Individually programmable start/stop function**  
By means of 2 start/stop inputs, up to 4 different measuring principles can be achieved, e.g. active or passive pulse width measurement, time interval measurement with one input or with separate inputs
- **Manual or electrical reset**  
Tamper-proof, due to lockable reset function
- **User-programmable setpoint**  
Start time at which the time counting should begin
- **AC or DC power supply**  
With sensor power supply
- **Inputs**  
As an alternative to the HTL inputs, devices with a 5 VDC input trigger level are available, for use as parallel displays for PLCs
- **Optional output**  
1 Hz clock pulse for active time measurement

### Applications for time and hour meters, short-time meters

- Time measurements such as hours run recording on all machines and plant, e.g. compressors, solariums, special lights and lamps.
- Accessories, OEM equipment or retrofitting to production machine
- Measurement of short times on processes and procedures, time recording (stop-watch function) at sporting events
- Hours run recording for motor vehicles and time monitoring for rally vehicles

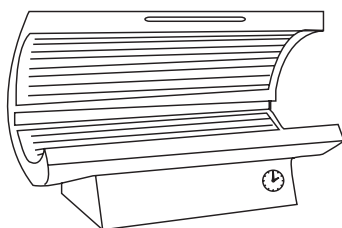

Hours run of UV lamps

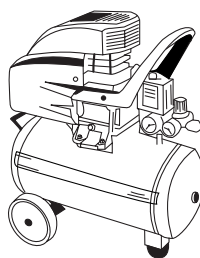

Operating hours

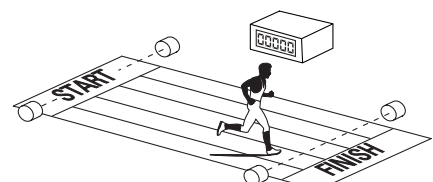

Short time measurement > 1 ms

## Time meter and short time meter **CODIX 543**

### Technical data:

Supply voltage:	10 ... 30 V DC, with reverse polarity protection 90 ... 260 V AC
Current consumption:	max. 50 mA, 6 VA
Display:	6-digit red 7-segment LED display; 14 mm [0.551"] high
Data backup:	EEPROM
Housing:	Dimension 96 x 48 mm [3.78 x 1.89"] according to DIN 43 700; RAL 7021, grey
Polarity of Inputs:	programmable, npn or pnp for all inputs
Input resistance:	approx. 5 kΩ
Resolution:	0.001 s
Reset time:	5 ms
Input switching level (standard version):	DC-version: Low: 0 ... 0.2 [0 ... 0.008"] x U <sub>B</sub> [V DC] High: 0.6 [0.024"] x U <sub>B</sub> ... 30 V DC

AC-version:	Low 0 ... 4 V DC High 12 ... 30 V DC
Input switching level (5 V version):	Low 0 ... 2 V DC High 4 ... 30 V DC
Voltage supply for sensors:	24 V DC ±15 %/100 mA at AC version
Power consumption: (Optocoupler)	max. 30 V, 10 mA
Ambient temperature:	-20 ... +65 °C [-4 ... 149 °F] non-condensing
Storage temperature:	-25 ... +70 °C [-13 ... 158 °F]
EMC:	according to EC EMC directive 89/36/EWG
Emitted interference:	EN 61000-6-4/EN 55011 class B
Immunity to interference:	EN 61000-6-2
Protection:	IP 65 front side
Weight:	approx. 150 g [5.291 oz]

### Block diagram:

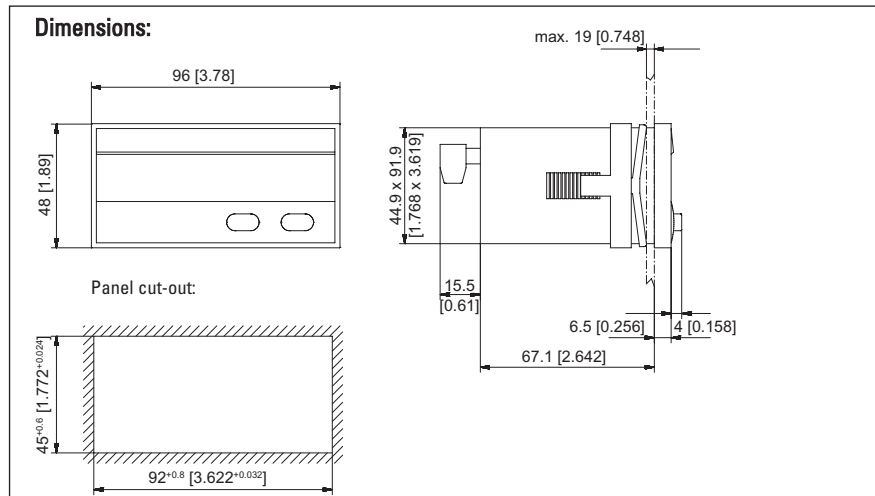
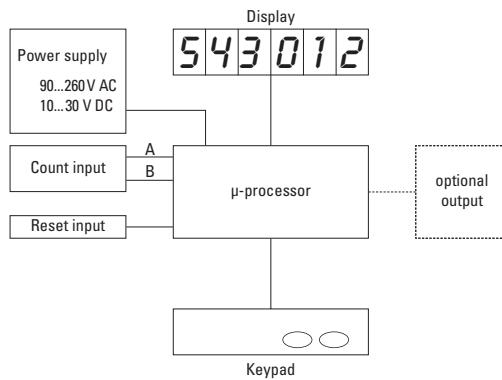

### Order code:

**6.543.01X.XX0**

Output 1 = Optocoupler output 2 = No output*	Input switch level 0 = Standard* A = 5 V	Power supply 0 = 90 ... 260 V AC* 3 = 10 ... 30 V DC*
--	--	---

\* standard stock model

### Connections:

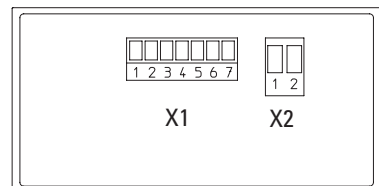

#### Connection: X2

Pin	AC-version	DC-version
1	90 ... 260 V AC	0 V DC (GND)
2	90 ... 260 V AC	10 ... 30 V DC

#### Connection: X1

Pin	AC-Version	DC-Version
1	Optocoupler output Emitter	
2	Optocoupler output Collector	
3	INP C (Frequency)	
4	INP B (Count)	
5	INP A (Count)	
6	GNDout	n.c.
7	+24 Vout	n.c.

### Delivery specification:

Digital display  
Mounting clip  
Seal  
Multilingual operating instructions

## Multifunction display *CODIX 544*

programmable as:

- Pulse counter
- Position display
- Frequency / speed display
- Timer/ short time meter



Power supply  
AC/DC



Front bezel  
dimensions

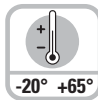

Wide temper-  
ature range



High IP  
protection  
rating



Plug-in screw  
terminal



Menu-driven  
programming

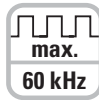

Pulse counter/  
Totaliser

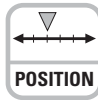

Position  
display



Frequency  
meter/  
Tachometer



Timer/  
Hour Meter



Frequency  
meter HRA

### Powerful

- **Fast count input**  
Input frequency max. 60 kHz
- **Robust housing**  
IP 65 protection
- **LED display**  
Very bright, 14 mm high
- **HRA – High Rate Accuracy System**  
Frequencies up to 38 Hz are calculated using time-interval (period duration) measurement.  
Frequencies > 38 Hz are calculated using a special time base (gate time) measurement. A very high accuracy of > 0.1% is achieved, even with very short gate times. The resulting measurement is available after a max. of 50 ms.
- **Fast start-up time**  
Detects incoming pulses just 16 ms after being switched on – so no pulses are lost with a simultaneous motor start-up



### User-friendly

- **Big keys**  
Can also be operated when using gloves
- **Easy to programme**  
Easy menu-driven programming and operation  
Possibility to enter the programming mode during operation, with authentication query

### Universal

- **Individually programmable scaling**  
Multiplication and division factor (0.0001 to 99.9999), to display corresponding engineering units, e.g. position in 1/10 mm and speed in RPM.
- **4 different count input modes**  
2-channel input for detecting count direction, difference or adding mode, quadrature x1, x2 or x4
- **Frequency measurement**  
Display in 1/min or 1/sec
- **Time counting**  
Pulse width or time interval measurement in hours, minutes or seconds, as well as real-time display
- **AC or DC power supply**  
With sensor power supply
- **Inputs**  
As an alternative to the HTL inputs, devices with a 5 VDC input trigger level are available, for use as parallel displays for PLCs
- **Optional output**  
Zero signal for position and count, zero-speed monitoring, 1 Hz clock pulse for active time measurement

### Applications for Multifunction Display

- Counting tasks such as quantity and piece counting, measuring and recording of speed and of operating and processing times
- Piece counting or tool-life measurement on die cutters, presses, extruders, wood-working machines, drilling machines,

- pick-and-place machines, guillotines, special-purpose vehicles etc.
- Positioning tasks on processing machines, such as sawing machines, milling machines, bending and folding machines, etc.

- Production data acquisition by means of piece counting (using difference or adding), or measurement of production times or production speeds.
- Totalizing flow, quantity and other scaleable media, or display of current flow rates.

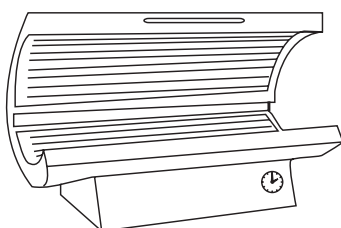

Hours run of UV lamps

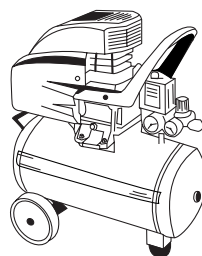

Operating hours

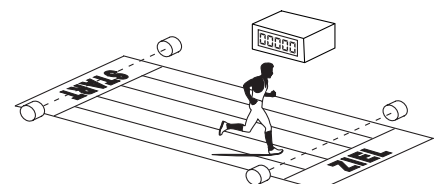

Short time measurement > 1 ms

## Multifunction display **CODIX 544**

### Technical data:

Supply voltage:	10 ... 30 V DC, with reverse polarity protection 90 ... 260 V AC
Current consumption:	max. 50 mA, 6 VA
Display:	6-digit red 7-segment LED display; 14 mm high [0.551"]
Data backup:	EEPROM
Housing:	Dimension 96 x 48 mm [3.78 x 1.89"] according to DIN 43 700; RAL 7021, grey
Polarity of Inputs:	programmable, npn or pnp for all inputs
Input resistance:	approx. 5 kΩ
Counting frequency*:	60 kHz, can be damped to 30 Hz depending on operating mode at position display max. 25 kHz
Reset time:	5 ms
Display range timer:	0.001 s ... 999999 h
Input switching level (standard version):	DC-version Low: 0 ... 0.2 [0 ... 0.008"] x U <sub>B</sub> [V DC] High: 0.6 x [0.024"] U <sub>B</sub> ... 30 V DC

	AC-version
	Low 0 ... 4 V DC
	High 12 ... 30 V DC
Input switching level (5 V version):	Low: 0 ... 2 V DC High: 4 ... 30 V DC
Voltage supply for sensors:	24 V DC ±15 %/100 mA at AC-versions
Accuracy:	Tacho meter: <0,1 % Timer < 50 ppm
Ambient temperature:	-20 ... +65 °C [-4 ... 149 °F]
Storage temperature:	-25 ... +70 °C [-13 ... 158 °F]
EMC:	according to EC EMC directive 89/36/EWG
Emitted interference:	EN 61000-6-4/EN 55011 class B
Immunity to interference:	EN 61000-6-2
Protection:	IP 65 front side
Weight:	approx. 150 g [5.291 oz]

\*for further specifications please refer to the manual

### Block diagram:

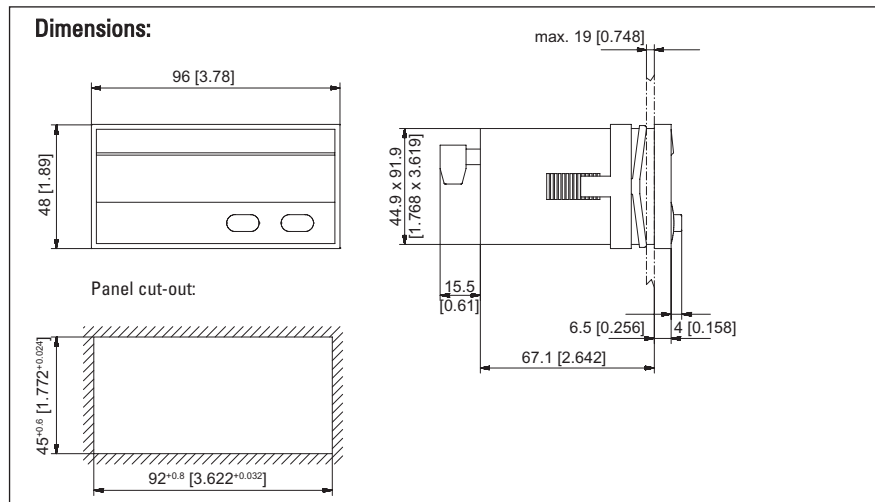
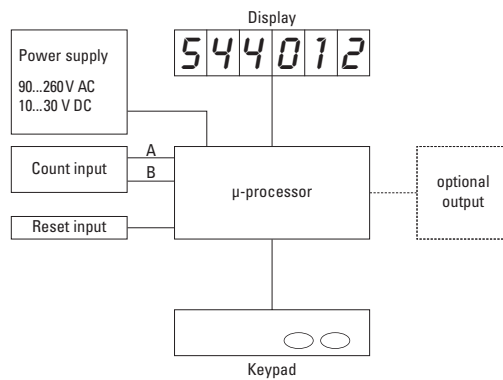

### Order code:

**6.544.01X.XX0**

Output  
1 = Optocoupler output\*  
2 = No output

Input switching level  
0 = Standard level\*  
A = 5 V level

Voltage supply  
0 = 90 ... 260 V AC\*  
3 = 10 ... 30 V DC

\* standard stock model

### Connections:

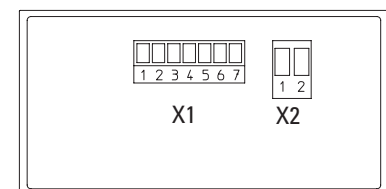

#### Connection X2:

Pin	AC-version	DC-version
1	90 ... 260 V AC	0 V DC (GND)
2	90 ... 260 V AC	10 ... 30 V DC

#### Connection X1:

Pin	AC-version	DC-version
1	Optocoupler-output Emitter	
2	Optocoupler-output Collector	
3	Set	
4	INP B	
5	INP A	
6	GNDout	n.c.
7	+24 Vout	n.c.

**Delivery specification:** Seal  
Digital display Multilingual operating instructions  
Mounting clip

## Universal with dual functions **CODIX 54U**

**4 dual functions in one device**  
 > solves all applications where 2 different values must be displayed simultaneously.

- Counter with 2 totalizing ranges
- Totaliser and time counter
- Totaliser and frequency counter
- Timer with 2 time ranges

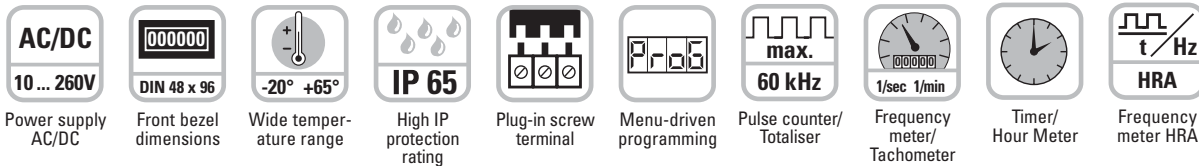

### Powerful

- **Fast count input**  
Input frequency max. 60 kHz
- **Robust housing**  
IP 65 protection
- **LED display**  
Very bright, 14 mm high
- **HRA – High Rate Accuracy System**  
Frequencies up to 38 Hz are calculated using time-interval (period duration) measurement.  
Frequencies > 38 Hz are calculated using a special time base (gate time) measurement. A very high accuracy of > 0.1% is achieved, even with very short gate times. The resulting measurement is available after a max. of 50 ms.
- **Fast start-up time**  
Detects incoming pulses just 16 ms after being switched on – so no pulses are lost with a simultaneous motor start-up



### User-friendly

- **Big keys**  
Can also be operated when using gloves
- **Easy to programme**  
Easy menu-driven programming and operation  
Possibility to enter the programming mode during operation, with authentication query  
Pressing the right key switches between displays

### Universal

- **Individually programmable scaling**  
Multiplication and division factor (0.0001 to 99.9999), to display corresponding engineering units, e.g. position in 1/10 mm and speed in RPM.
- **Separate factors for frequency- and pulse counting**
- **AC or DC power supply**  
With sensor power supply
- **Inputs**  
As an alternative to the HTL inputs, devices with a 5 VDC input trigger level are available, for use as parallel displays for PLCs
- **Timer specials**  
Timer or hours-run meter with various Start Stop measurements, time range settings in hours, minutes or seconds, with decimal point. Resolutions up to 1/1000 can be programmed

### Applications for dual functions

- **Pulse and frequency (speed)**  
e.g. production data acquisition: total piece count and speed on OEM equipment, flow rate measuring systems – total flow and current flow
- **2 pulse counters**  
Measurement of batch and total piece count or of daily production count and total count values

- **Pulse and time (Maintenance counter)**  
Used in the lift industry as trip counters and hours-run meters and on production machines for piece and time counting, flow and time measurement, materials handling time and quantities

- **2 timers**  
Measurement of total time and order-specific times, maintenance intervals and total time, time of day and total time

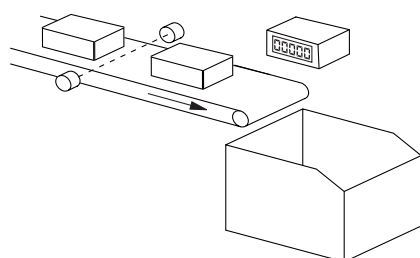

Piece count on conveyor and production speed

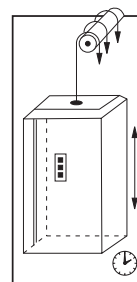

Trip counter and hours-run

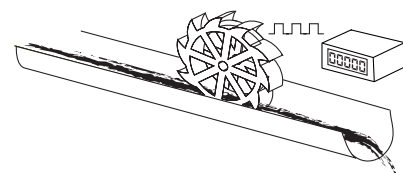

Flow rate and total volume

## Universal with dual functions **CODIX 54U**

### Technical data:

Supply voltage:	10 ... 30 V DC, with reverse polarity protection 90 ... 260 V AC
Current consumption:	max. 50 mA, 6 VA
Display:	6-digit 7-segment red LED display; 14 mm [0.551"] high
Data backup:	EEPROM
Housing:	Dimension 96 x 48 mm [3.78 x 1.89"] according to DIN 43 700; RAL 7021, grey
Polarity of Inputs:	programmable, npn or pnp for all inputs
Input resistance:	approx. 5 kΩ
Counting frequency*:	60 kHz, can be damped to 30 Hz depending on operating mode
Display range:	0.001 s ... 999999 h
Reset time:	5 ms
Input switching level (standard version):	DC-version: Low: 0 ... 0.2 [0 ... 0.008"] x U <sub>B</sub> [V DC] High: 0.6 [0.024"] x U <sub>B</sub> ... 30 V DC

AC-version:	Low 0 ... 4 V DC High 12 ... 30 V DC
Input switching level (5 V version):	Low 0 ... 2 V DC High 4 ... 30 V DC
Voltage supply for sensors:	24 V DC ±15 %/100 mA at AC version
Accuracy:	<0.1 % (Frequency display/Rate meter) <50 ppm (Timer)
Ambient temperature:	-20 ... +65 °C [-4 ... 149 °F] non-condensing
Storage temperature:	-25 ... +70 °C [-13 ... 158 °F]
EMC:	according to EC EMC directive 89/36/EWG
Emitted interference:	EN 61000-6-4/EN 55011 class B
Immunity to interference:	EN 61000-6-2
Protection:	IP65 from front
Weight:	approx. 150 g [5.291 oz]

\*for further specifications please refer to the manual

### Block diagram:

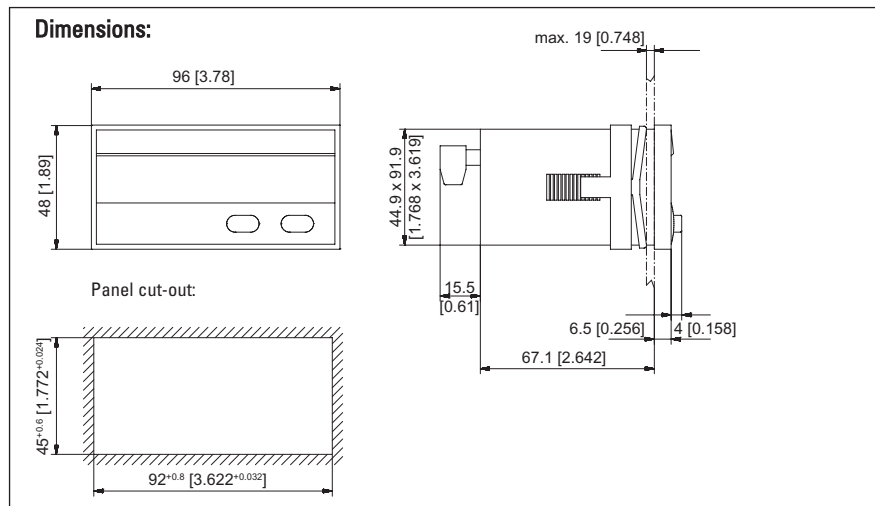
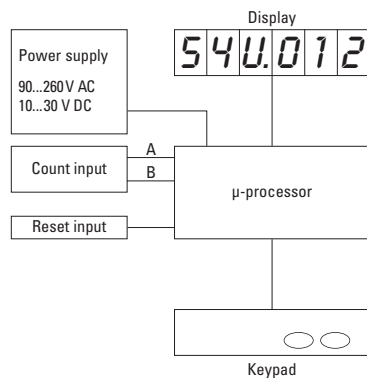

### Order code:

6.54U.012.XX0

Input switching level  
0 = Standard\*  
A = 5 V level

Power supply  
0 = 90 ... 260 V AC\*  
3 = 10 ... 30 V DC

### Connections:

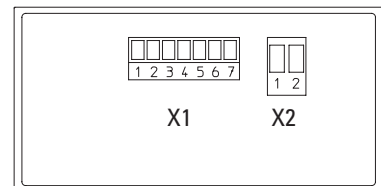

### Connection: X2

Pin	AC-version	DC-version
1	90 ... 260 V AC	0 V DC (GND)
2	90 ... 260 V AC	10 ... 30 V DC

### Connection: X1

Pin	AC-Version	DC-Version
1	n.c.	
2	n.c.	
3	Reset	
4	INP B	
5	INP A	
6	GNDout	n.c.
7	+24 Vout	n.c.

**Delivery specification:**  
Digital display  
Mounting clip

Seal  
Multilingual operating instructions

## Universal Preset Counter *CODIX* 923 / 924

<b>DC</b> 10 ... 30V	<b>AC</b> 90 ... 260V	<b>-20° +65°</b>	<b>DIN 48 x 48</b>	<b>HRA</b>	<b>Menu driven programming</b>	<b>IP 65</b>	<b>Plug-in screw terminal</b>	<b>max. 60 kHz</b>	<b>1 or 2</b>	<b>Multifunction</b>
Supply voltage	Temperature	DIN front panel	Frequency meter HRA	Menu driven programming	High IP value	Plug-in screw terminal	High frequency	Preset counter	Multifunction	
<b>2 x 6 LCDs</b>	<b>POSITION</b>									
2 x 6 LCDs	Position display									
								<b>Batch counter</b>	<b>Totaliser</b>	
								Batch counter	Totaliser	



Made in Germany by Kübler

### Multifunction:

- Counter, Tachometer and Timer – all in one device
- Can be used as preset counter, batch counter or totaliser (overall cumulative count)
- 1 or 2 presets (additional presets on request)
- Relay or optocoupler outputs
- Wide choice of count modes for pulse inputs, time or frequency
- Averaging, start delay (Tachometer)
- Scalable display with multiplikation and division factor, set value
- Step or tracking presets

### Fast:

- Direct input of the presets via the front keys or the Teach-In input
- Fast installation thanks to plug-in screw terminals and integrated sealing gaskets
- Max. count frequency 60 kHz

### User-friendly:

- Simultaneous display of the actual value, presets, batch count or total count
- Annunciators for the displayed preset and for the output status
- 3 predefined settings for the most common parameter settings
- Direct entry into the programming
- Tracking presets eliminate the need for reprogramming of the pre-signal
- Minimum installation depth
- 4 stage RESET modes
- 3 stage key lockout

### Technical data:

Supply voltage:	90 ... 260 V AC/max. 8 VA, 50/60 HZ, External fuse protection T 0.1 A 10 ... 30 V DC/max. 1.5 W External fuse protection T 0.2 A
Display:	2-line 6-digits LCD display LCD pos. (green) backlighting
Count inputs:	
Polarity of the inputs:	programmable for all inputs in common NPN/PNP
Input resistance:	5 kΩ
Count frequency:	max. 55 kHz (details see manual)
Min pulse duration of the inputs:	10 ms / 1 ms
Switching levels with AC-supply:	
HTL-level	Low: 0 ... 4 V DC High: 12 ... 30 V DC
5 V-level	Low: 0 ... 2 V DC High: 3.5 ... 30 V DC
Switching level with DC-supply:	
HTL-level	Low: 0 ... 0.2 x U <sub>B</sub> High: 0.6 x U <sub>B</sub> ... 30 V DC
5 V-level	Low: 0 ... 2 V DC High: 3.5 ... 30 V DC
Pulse shape:	variable, Schmitt-Trigger characteristics
Output	Switching voltage max. 250 V AC/110 V DC Switching current max. 3 A AC/A DC

Output 1	Switching current min. 30 mA DC Switching capacity max. 750 VA/90 W Mech. service life (switching cycles) 2 x 10 <sup>7</sup> N° of switching cycles at 3 A/250 V AC 1 x 10 <sup>5</sup> N° of switching cycles at 3 A/30 V DC 1 x 10 <sup>5</sup> Relay closing contact, programmable as normally open (NO) or normally closed (NC)
Output 2	Mech. service life (switching cycles) 20 x 10 <sup>6</sup> N° of switching cycles at 3 A/250 V AC 5 x 10 <sup>4</sup> N° of switching cycles at 3 A/30 V DC 5 x 10 <sup>4</sup> Relay with changeover contact
or npn optocoupler:	switching power 30 V DC/10 mA U <sub>CESAT</sub> at IC = 10 mA: max. 2.0 V U <sub>CESAT</sub> at IC = 5 mA: max. 0.4 V
Reaction time of the outputs:	Relay: approx 7 ms Optocoupler: approx 1 ms, Details see instruction manual
Response time of the frequency counter:	100/600 ms, Details see instruction manual
Data retention:	min. 10 years, EEPROM
Count modes:	
Pulse counter:	cnt.dir, up.dn, up.up, quad, quad 2, quad4, A/B, (A-B)/A x 100%
Frequency counter:	A, A-B, A+B, quad, A/B, (A-B)/A x 100%
Timer:	FrErun, Auto, InpA.InpB., InpB.InpB.



## Technical Data:

Voltage supply for sensors:	
AC supply	24 V DC ± 15%, 80 mA
DC supply	max. 80 mA, external voltage supply is connected through
Operating temperature:	-20 °C ... +65 °C
Storage temperature:	-25 °C ... +75 °C

Humidity:	RH 93% at +40 °C, non-condensing
EMC:	CE compliant to EU directive 89/36/EWG
Standards:	EN 61 000-6-4/EN 55011 class B EN 61000-6-2
UL (applied for):	File-N°.: E128604
Protection:	IP65 (front)
Weight:	approx. 125 g

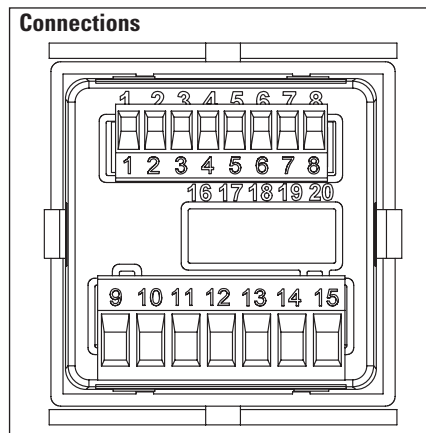
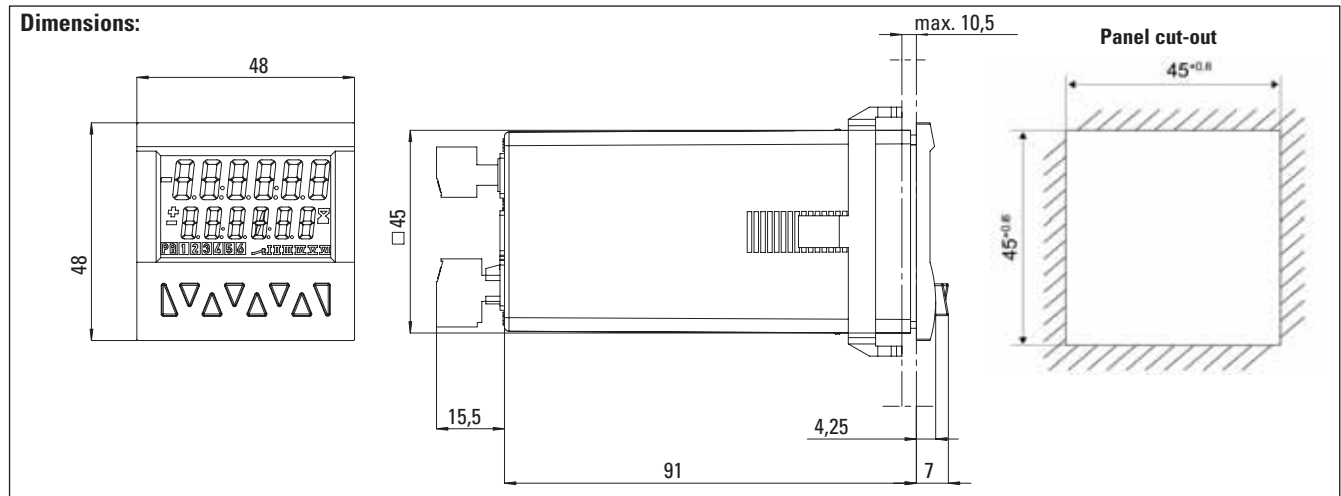

### Signal and control inputs

- 1 Sensor voltage supply  
AC: 24 VDC/80 mA  
DC: UB interconnected
- 2 GND (0 VDC)
- 3 INP A (Signal input A)
- 4 INP B (Signal input B)
- 5 RESET (Reset input)
- 6 LOCK (Key locking input)
- 7 GATE (Gate input)
- 8 MPI (User input)
- 16 ... 20:  
Additional optional inputs or outputs or interfaces

### Version with relays/optocouplers

- |                                    |                  |
|------------------------------------|------------------|
| 9 Relay contact C./Collector       | } Output 1       |
| 10 Relay contact N.O./Emitter      |                  |
| 11 Relay contact C./Emitter        | } Output 2       |
| 12 Relay contact N.O./not assigned |                  |
| 13 Relay contact N.C./ Collector   | } Supply voltage |
| 14 AC: 90..260 VAC N~              |                  |
| DC: 10..30 VDC                     |                  |
| 15 AC: 90..260 VAC L~              |                  |
| DC: GND (0 VDC)                    |                  |

### Delivery specification:

- Preset counter
- Mounting clip
- Operating instructions

## 6.92X.01XX.XX0

### Order code:

Number of presets  
3 = 1 preset  
4 = 2 preset

Outputs  
0 = Relays  
1 = Optocouplers (only 924)

LCD options  
0 = no backlighting  
1 = green backlighting

Input trigger level  
0 = Standard level (HTL)  
A = 5 V-level

Supply voltage  
0 = 90–260 V/AC  
3 = 10–30 V/DC

Options: Additional inputs or outputs or interfaces on request

### Standard stock models:

6.923.0100.000 6.924.0100.000  
6.923.0100.300 6.924.0100.300

## Areas of application for 923/924:

### ■ Pulse counter

#### Functions/ Count modes

- Count with direction mode
- Difference mode
- Quadrature mode quad/quad2/quad4
- Add, Sub, automatic reset
- 2-input adding mode A+B
- Ratio measurement A/B
- Percentage difference measurement  $(A-B)/A \times 100\%$
- Batch counting
- Totaliser (Overall total)
- Multiplication and division factor (up to 99.999)
- Set value
- Step or tracking preset

#### Application examples

##### CountDir

Roller shutter door with automatic shutoff

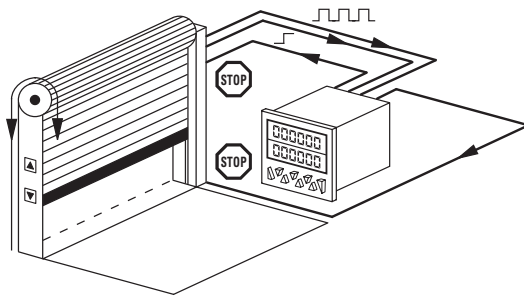

##### Quad

Running direction and position on milling machines

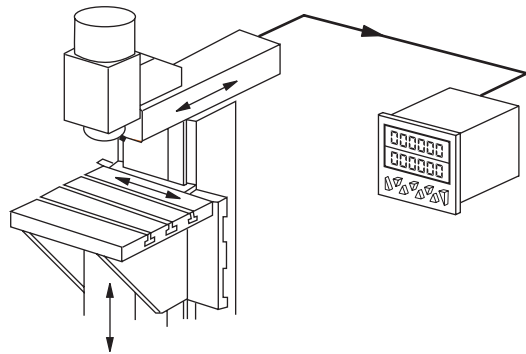

##### UpDown

Automatic subtraction of faulty or reject parts from the total piece count

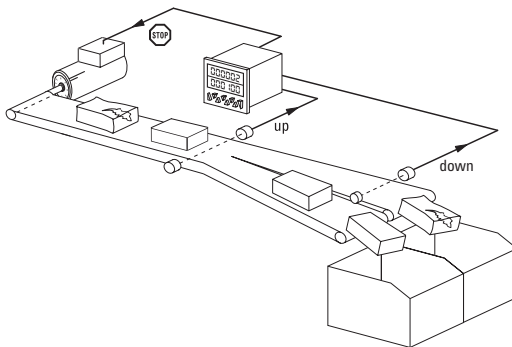

##### Batch

Logging of piece numbers and packing units plus control of replenishment of packing cartons

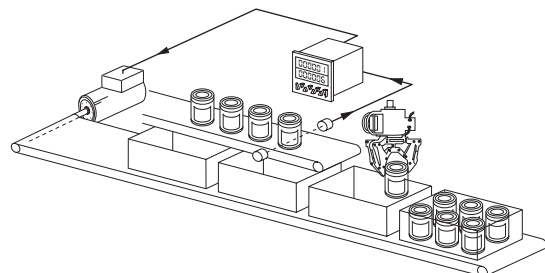

##### UpUp

Adding up of two parallel or staggered production lines

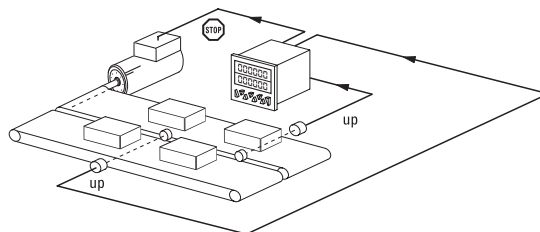

##### Add tot

Cut-to-length with overall total count

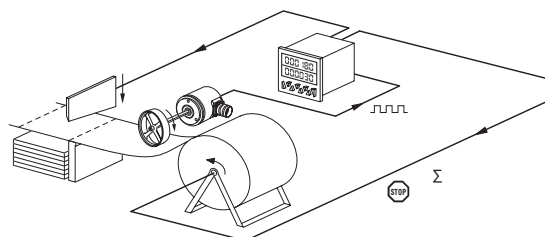

## Areas of application for 923/924:

### ■ Frequency counter (Tachometer)

#### Functions/ Count modes

- A
- B
- A - B
- A + B
- A / B
- (A - B) / A x 100 % (percentage display)
- Quad (Phase discriminator with recognition of direction)
- Averaging
- Start delay
- 2nd tacho input
- Gate input
- Multiplication and division factor (up to 99.9999)

<b>Application examples</b>	<b>A - B</b> Synchro monitoring and control of two conveyor belts 	<b>Speed regulation with indication of direction</b> 
	<b>Ratio measurement A/B</b> 	<b>Ratio measurement e.g. for speed alignment</b> 

### ■ Time and hours-run meter (Timer)

#### Functions/ Count modes

- FrErun (Control via gate input)
- Auto (Start via Reset, Stop at preset)
- InpB.InpB (Start with first edge at InpB., Stop with second edge InpB.)
- InpA. InpB (Start with InpA., Stop with InpB.)
- Totaliser (Overall total)
- Batch counting
- Set value
- Step or tracking preset

<b>Application examples</b>	<b>Interval measurement InpB. InpB</b> 	<b>FrErun</b> Measurement of overall time from switching on the conveyor belt till switching off 
	<b>Run-time measurement InpA. InpB.</b> 	<b>Auto</b> time-controlled production line 

## Universal Preset Counter **CODIX** 923 / 924

Your control solution, ready-to-go · very easy to operate ·  
direct display · expandable via module individual functionality.



### Multifunction

More than just preset counters: the **CODIX** 923/924 are multi-talented and can handle the display, measurement and control of pulses (counter), frequencies (tacho) and time (timer) using numerous count functions and modes.

**Open to many applications.** The great advantage of the **CODIX** 923/924 preset counters: they offer a simple and cost-effective solution for many local standard control functions. It is not necessary to have in-depth programming knowledge when installing or using the product, which does away with the need for costly service engineers.

### Expandable

Numerous logic functions and preconfigured, selectable operating modes for a variety of applications, including for example positioning and batch counting, make the counter a real alternative to a PLC – and with the benefit of a display included.

The devices are so designed that they are expandable for OEM applications. Both hardware and software can be modified and expanded. PCB-board receptacles are provided in the counter for hardware upgrade purposes:

- Up to 10 inputs
- Up to 6 optocoupler outputs
- Up to 4 relay outputs
- Interface RS 232/485
- Individual functions

The software can be specifically customised to OEM applications. This includes the logic behaviour of the inputs and outputs (I/O functionality) or the whole display unit.

Expandable on request via modules:

- 4 additional inputs
- or 4 additional optocoupler outputs
- or 2 additional relay outputs
- or RS 232/485 interfaces

Application examples:

- Limit switch monitoring
- Special functions/PLC function
- Initiation of fixed program sequences
- Control of several processes
- Special protocols
- Print commands for logging

Individual customisation of software to your application.

For example:

- Separate inputs for total counter and preset counter
- Separate scaling of input A and B
- Programmable measuring period for the tachometer
- Measurement of rotary speeds based on time
- Processing time, measurement of time based on frequency

Expandable hardware:



Customisable software:



With your logo:



Free-of-charge for 100+ pcs.

Typically a simple OEM customisation is worthwhile for annual quantities of 20-50 pcs. We would be happy to solve this task for you quickly, professionally and economically.  
Phone +49 (0) 77 20 - 39 03-38  
or info@kuebler.com

**Universal Preset Counter *CODIX* 923 / 924**

**User-friendly**



*Fresh, modern design that further enhances your panel or equipment.*

**Simple filing-cabinet programming structure** for fast entry of parameters. Quickly operational: after each parameter has been modified, it is possible to exit the programming by means of the reset key.

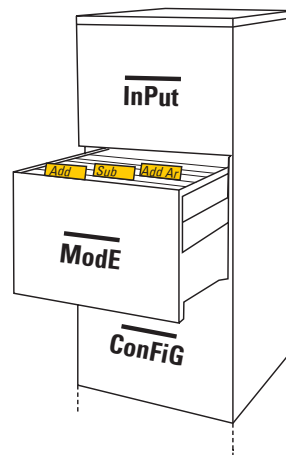

**Convenient time-saving installation:** Plug-in screw terminal connections with cage clamp terminals. IP 65 sealed front bezel as standard. Saves additional time & effort for protection when installing. Minimal installation depth – will fit anywhere



**Comprehensive, large display:** 2-line, 2 x 6-digit LCD display with sign, leading zero suppression, giving a display range from -999 999 to +999 999. Optional backlighting for good readability in all situations.

**Easy-to-operate** without programming knowledge. Direct access to the programming mode for all count functions. User-friendly, thanks to the simplified programming structure and alpha-numeric display of the parameters.



**Easy-to-understand:** thanks to the use of annunciators for the displayed preset and the status of both outputs, as well as the simultaneous display of the actual value and the presets or the auxiliary counters.



**New: MPI input** (multiple purpose input) with the functions: Display Hold, Set and Teach-In.



**The compact decade key-pad:** allows for a large display and enables simple direct entry of the presets.

**Three predefined settings:** with parameter settings for the most common applications.

**Preset via Teach-In input:** for simple error-free entry of the preset. A reset key plus programming mode key are already integrated.



## Type 903/904



### Your benefit

- 2 line LCD display
- Programmable as impulse counter, frequency meter or time meter with sign and zero blanking
- Power supply  
90 ... 260 V AC or 10 ... 30 V DC
- approval
- Batch mode

### Further product features

- Display range -199 999 ... 999 999 with zero blanking
  - Easy to operate and set the preset values via 4 keys
  - Relay or optocoupler-output
  - Scaling factor 0.0001 ... 9.9999
- 903:** 1 preset value, 1 output  
**904:** 2 preset values, 2 outputs

### Technical data:

Supply voltage:	10 ... 30 V DC, max. 1,1 W with reverse polarity protection. 90 ... 260 V AC max. 4 VA	or npn optocoupler:	with open collector and emitter switching power 30 V DC/15 mA
Display:	2 line LCD display, 6-digits	Output 2     Relay:	with potential free contact, programmable as normally open or normally closed. switching voltage max. 250 V AC/125 V DC, switching current max. 3 A switching current at DC min. 30 mA switching power at DC 90 W at AC max. 750 VA
Count inputs:	2 count inputs, 4 input modes are programmable	or npn optocoupler:	with open collector and emitter switching power 30 V DC/15 mA
Polarity of the inputs:	programmable for all inputs in common	Reaction time of the outputs:	relay: approx. 7 ms optocoupler: approx. 1 ms
Input resistance:	approx. 10 kΩ	Data retention:	min. 10 years or 1x10 <sup>6</sup> memory cycles
Count frequency:	via DIL switches for INP A and INP B can be set separately 30 kHz 10 kHz for input modes E3 and E4 (quadrature) for automatic repeat - 900 Hz without losing counts (500 Hz for input mode E4)	Transmitter voltage:	24 V DC -40 %/+15 %, 100 mA at 90 .. 260 V AC with optional backlighting: 24 V DC -40 %/+15 %, 60mA at 90 ... 260 V AC
Min. pulse duration of the inputs:	5 ms	Ambient temperature:	0... +50 °C [32 ...122 °F]
Input sensitivity:	DC supply voltages: Low: 0 ... 0.2 x U <sub>B</sub> [V DC] High: 0.6 x U <sub>B</sub> ... 30 [V DC] AC supply voltages: Low 0 ... 4 V DC High 12 ... 30 V DC	Storage temperature:	-25 ... +70 °C [-13 ... 158 °F]
Pulse shape:	variable (Schmitt-Trigger characteristics)	EMC:	according to EC EMC directive 89/36/EWG
Output 1     Relay:	with potential free contact, programmable as normally opened or normally closed. switching voltage max. 250 V AC/125 V DC, switching current max. 3 A. switching current at DC min. 30 mA switching power at DC 90 W at AC max. 750 VA	Emitted interference:	EN 61 000-6-4/EN 55011 class B
		Immunity to interference:	EN 61 000-6-2
		UL:	File E128604
		Protection:	IP 65 front side EX version IP 54
		Weight:	approx. 240 g [8.466 oz], AC version with relay

### Inputs:

#### INP A, INP B

Count inputs: the max. count frequency of 10kHz can be damped for each channel to 30 Hz.

#### Gate

Static gate input; no counting while this input is activated

### Reset

Dynamic reset input; it is connected in parallel to the red reset key and sets the counter to zero (adding mode) or to the preset value (subtracting mode)

### Key

Static keyboard lock input; while this input is activated, the front keys are locked for operations

### Outputs:

2 potential free outputs (903: 1 output), versions with relay or optocoupler available

### Programming:

The types 903 and 904 are programmed via only 4 keys on the front side. Trouble-free and intuitive operation through clear text user guidance on the display. The operating parameters are chosen from a menu. The device can be used as:

1. Pulse counter
2. Frequency meter
3. Time meter

Therefore the following functions are programmable:

### Polarity of the inputs:

Positive (pnp) or negative (npn) polarity of the inputs. The selected polarity applies to all inputs.

### Operating modes, impulse counter and timer:

- adding, starting at zero
- subtracting, starting at the preset value (903) or at preset value 2 (904)
- adding with automatic reset to zero at preset value (903) or preset value 2 (904)
- subtracting with automatic reset to preset value (903) or preset value (904) at zero.

### Input modes, impulse counter and frequency meter:

- E1 1 count input, 1 count direction input
- E2 1 Count input up  
1 Count input down
- E3 Quadrature input  
to connect encoders with 2 signals shifted by 90°

- E4 Quadrature input with pulse doubling  
to connect encoders with 2 signals shifted by 90°

### Decimal places:

The display is possible with two or three decimal places

### Scaling factor:

For optimizing the operation with an encoder a scaling factor of 0.0001 ... 9.9999 may be programmed

### Output signal:

Selectable as NO contact or NC contact, positive or negative timed signal (duration 0.01 ... 99.99 s)

### Gate time for frequency meter:

Selectable from 0.01 ... 99.99 s

### Hour meter:

Timing in h, min or s, with a resolution of 0.001, 0.01, 0.1 or h:min:s

### Applications:

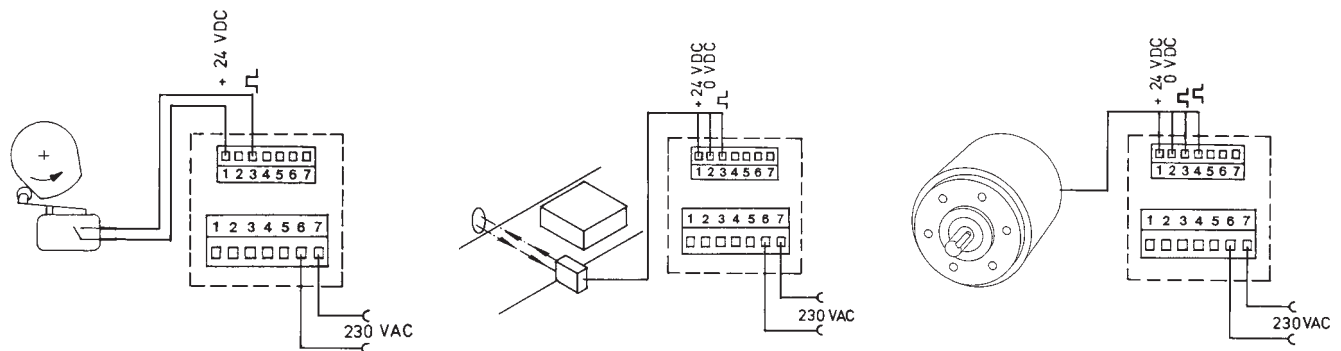

control via light barrier

control via encoder

### Connection diagram 904:

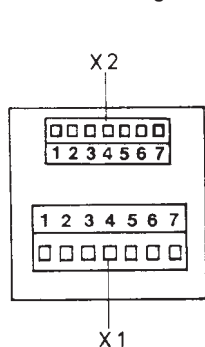

Pin connection X1:

Pin	AC version	DC version
1	Output 1 Relay collector at optocoupler output	
2	Output 1 Relay emitter at optocoupler output	
3	Output 2 Relay common contact (c) emitter at optocoupler output	
4	Output 2 Relay normally open (NO)	
5	Output 2 Relay normally closed (NC) collector at optocoupler output	
6	Supply voltage	
	90 ... 260 V AC	11 ... 30 V DC
7	90 ... 260 V AC	0 V DC (GND)

Pin connection X2:

Pin	Description	AC version	DC version
1	+24 V DC	Transmitter voltage supply	n.c.
2	0 V DC (GND)	GND	n.c.
3	INP A	Count input A	
4	INP B	Count input B	
5	Reset	Reset input	
6	Gate	Gate input	
7	Key	Key locking input	

**Dimensions:**

903/904

Panel cut-out 45 x 45 mm [1.772 x 1.772"]

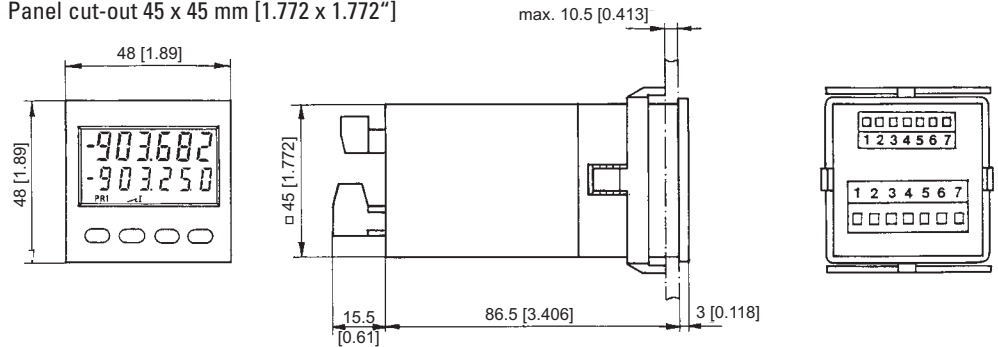

903/904 with front bezel no 2

Panel cut-out 50 x 50 mm [1.969 x 1.969"]

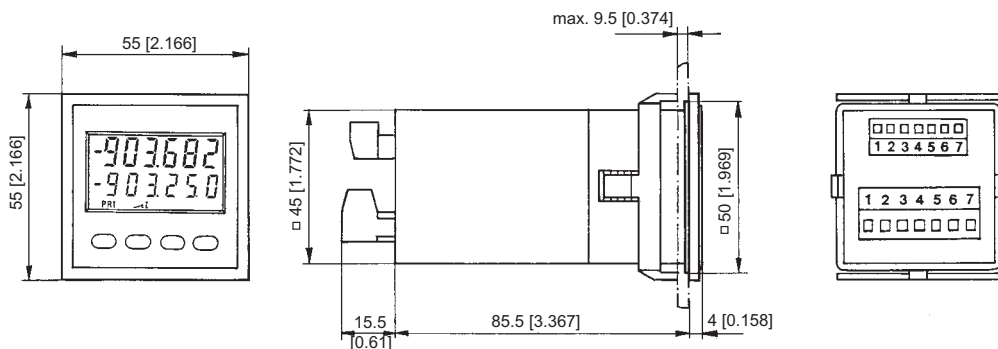

903/904 with front bezel no. 3

Panel cut-out 50 x 50 mm [1.969 x 1.969"]

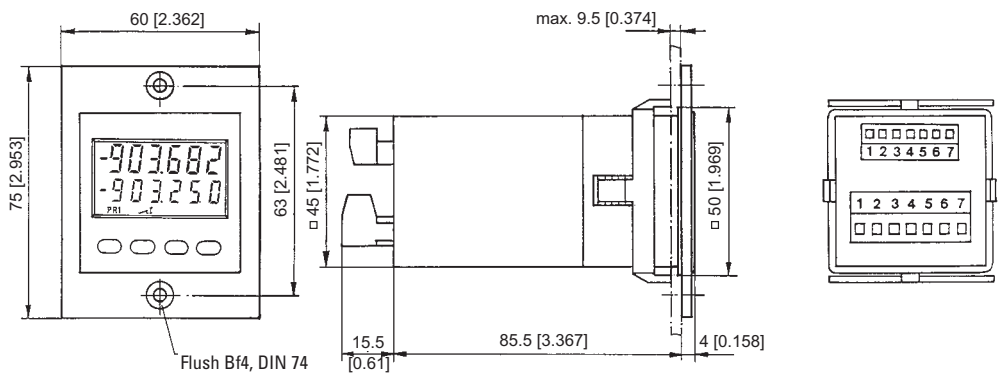

**Delivery specification:**

- Counter
- 2 Lithium batteries
- 1 Screw terminal
- 1 Front bezel for screw mounting  
Panel cut-out 50 x 50 mm [1.969 x 1.969"]

- 1 Front bezel for spring clip mount  
Panel cut-out 50 x 50 mm [1.969 x 1.969"]
- 1 Spring clip
- 1 Template for panel cut-out
- 1 Operating instruction

**Order code:**

**6.90X.01X.XXX**

**Type**  
 903 = Preset counter with one preset\*  
 904 = Preset counter with two presets\*

**Outputs**  
 0 = Relay\*  
 1 = Optocoupler

**Options**  
 00 = Without\*  
 10 = Backlit LCD\*

**Supply voltage**  
 0 = 90 ... 250 V AC\*  
 3 = 11 ... 30 V DC\*  
 5 V input level: Order code: 6.XXX.01X.XXX.5V

\* standard stock model



## Type 715



### Your benefit

- 5-digit preset counter with one preset point, add./subtr.
- Bright 5 digit LED display with 7.5 mm [0.295"] high characters
- Programmable as pulse counter, frequency meter or timer
- Supply voltage: 230 V AC, 115 V AC or 11 ... 30 V DC
- approval

### Further product features

- Display range -19999 ... 9999 with zero blanking
- Easy programming of preset point; one key for each digit
- Relay or optocoupler output
- Prescaling factor 0.001 ... 9.999



### Technical data:

Supply voltage:	11 ... 30 V DC, with reverse polarity protection 115 V AC, 230 V AC	switching voltage max. 250 V AC/300 V DC switching current max. 3 A, switching current for DC min. 30 mA
Current consumption:	max. 100 mA, 4 VA	switching performance: max. 50 W for DC max. 2000 VA for AC
Display:	5-digit 7-segment red LED display 7.5 mm [0.295"] high characteristics	Optocoupler: with open collector and emitter switching performance max. 30 V DC, 15 mA
Polarity of input signals:	programmable, all inputs in common	Responding time of outputs: Relay: approx. 6 ms Optocoupler: approx. 1 ms
Input resistance:	approx. 10 kΩ	Data retention: min. 10 Years or 10 <sup>6</sup> memory cycles
Count frequency:	via DIL switches separately selectable for INP A and INP B 30 Hz, 10 kHz (7.5 kHz for input mode E4) automatic reset 1 kHz without count losses (600 Hz for input mode E4)	Transmitter voltage: 24 V DC -40 %/+15 %, 80 mA unregulated for AC versions
Min. pulse length of the control inputs:	5 ms	Ambient temperature: 0 ... +50 °C [32 ... 122 °F]
Input sensitivity:	DC supply voltages: Low: 0 ... 0.2 x U <sub>B</sub> [V DC] High: 0.6 x U <sub>B</sub> ... 30 V DC AC supply voltages: Low 0 ... 4 V DC High 12 ... 30 V DC	Storage temperature: -25 ... +70 °C [-13 ... 158 °F]
Pulse shape:	variable (Schmitt Trigger characteristic)	Emitted interference EN 61 000-6-4/EN 55011 class B
Output Relay:	with potential-free change-over contact	Immunity to interference EN 61 000-6-2
		UL certified: File E128604
		Protection: IP 65 front side
		Weight: approx. 240 g [8.466 oz], (AC-version with relay)

### Applications:

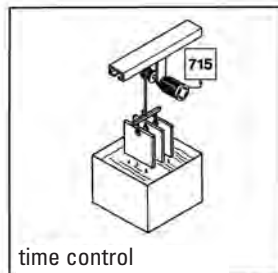
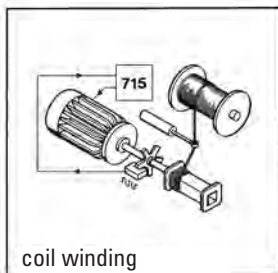
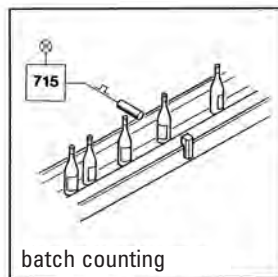
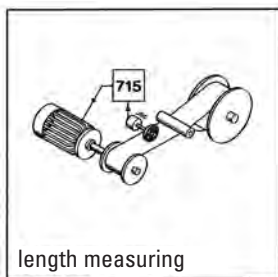

### Operating modes

Operating modes	Counting starts at	Output signal at count value	Kind of signal
1	0	≥ preset value	permanent or timed signal
2	preset value	≤ 0	permanent or timed signal
3	0	= preset value	timed signal and autom. reset
4	preset value	= 0	timed signal and autom. reset

## Selection of basic function

### 1. Pulse counter

- Mode:** see table
- Decimal point:** 0 ... 3 decimal places (only optical function)
- Polarity:** npn or pnp
- Input modes:**
- E1: One count input and one count direction input. While this input is not activated the counter adds, if it is activated the counter will subtract.
  - E2: Differential input, one up input and one down input
  - E3: Quadrature input for two lines of count pulses 90° out of phase. Up and down counting is automatic.
  - E4: Quadrature input with pulse doubling. Each pulse edge of count input "A" will be counted. Up and down counting is automatic.
- Prescaling factor:** 0.001 ... 9.999
- Output signal:** Permanent signal or timed signal selectable (0.01 ... 99.98 s)

### 2. Frequency counter

- Gate:** Gate time selectable from 0.001 ... 99.99 s
- Decimal point:** 0 ... 3 decimal places
- Polarity:** npn or pnp
- Input modes:** see pulse counter E1 ... E4
- Scaling factor:** 0.001 ... 9.999
- Output signal:** Permanent or timed signal selectable (0.01 ... 99.98 s)

### 3. Timer

- Operating mode:** see pulse counter
- Counting:** s, min or h;  
Resolution: 0.001; 0.01; 0.1 or 1.0
- Polarity:** npn or pnp
- Output signal:** Permanent signal or timed signal (0.01 ... 99.98 s)

## Connection diagram:

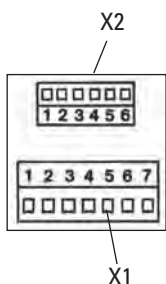

Plug connection X1:

Pin	115/230 V AC version	11 ... 30 V DC version
1	+24 V DC transmitter voltage	–
2	0 V DC (GND)	–
3	Relay output common contact (C) Optocoupler output emitter	
4	Relay output normally open contact (NO)	
5	Relay output normally closed (NC) Optocoupler output collector	
6	115 V AC/230 V AC	11 ... 30 V DC
7	115 V AC/230 V AC	0 V DC (GND)

Plug connection X2:

Pin	Designation	Function
1	INP A	Count input A
2	INP B	Count input B
3	Gate	Gate input
4	Reset	Reset input
5	Latch	Display stop input
6	Key	Keyboard lock input

**Dimension:**

715: panel cut-out 45 x 45 mm [1.772 x 1.772"]

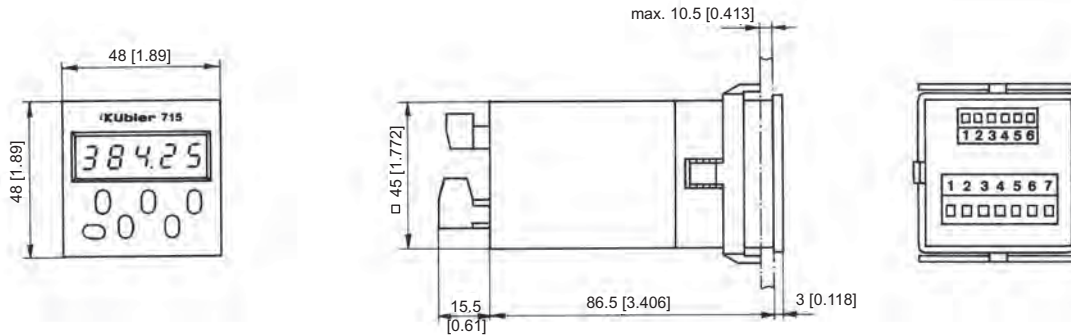

715: with front bezel 2  
panel cut-out 50 x 50 mm [1.969 x 1.969"]

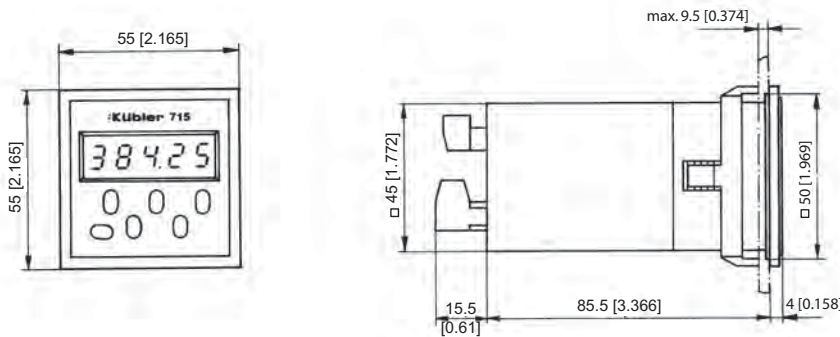

715: with front bezel 3  
panel cut-out 50 x 50 mm [1.969 x 1.969"]

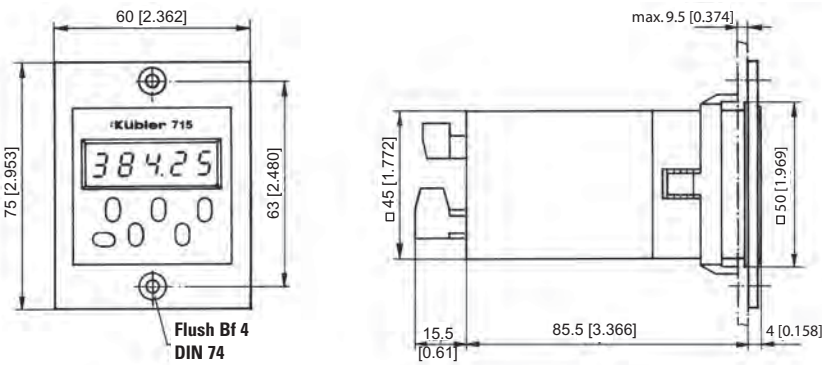

**Delivery specification:**

- Counter 715
- 1 Screw terminal plug 7 pin
- 1 Screw terminal plug 6 pin
- 1 Bezel for screw mount  
panel cut-out 50 x 50 mm [1.969 x 1.969"]
- 1 Bezel for clip mount  
panel cut-out 50 x 50 mm [1.969 x 1.969"]
- 1 Panel mounting clip
- 1 Panel cut-out template
- 1 Operating manual

**Order code**

6.715.01X.X00

Supply voltage  
0 = 230 V AC\*  
1 = 115 V AC\*  
3 = 11 ... 30 V DC\*

Output  
0 = Relay\*  
1 = Optocoupler

\* standard stock model

## Type 716/717 and 717 EX



### Your benefit

- Very bright 8 mm [0.315"] high display
- Programmable as a pulse counter, frequency meter or an operating time counter
- Wide range Power supply  
90 ... 260 V AC or  
10 ... 30 V DC
- approval
- -proof version

### Further product features

- Display range -199 999 ... 999 999 with zero blanking
- Easy to use and programmable with only 4 keys
- Option: serial interface RS 232, RS 422, RS 485
- Relay or optocoupler output
- Scaling factor 0.0001 ... 99.9999
- 716:** one preset
- 717:** two presets

### Technical data:

Supply voltage:	10 ... 30 V DC, max. 1.2 W with reverse polarity protection 90 ... 260 V AC, max. 5 VA
Display:	6-digit 7-segment red LED; 8 mm [0.315"] high
Counting inputs:	2 counting inputs, 4 types of programmable inputs
Polarity of the inputs:	programmable, common for all inputs
Input resistance:	approx. 10 k $\Omega$
Counting frequency:	20 kHz, can be reduced to 30 Hz
Minimum pulse duration for inputs:	5 ms
Input switching level:	DC version: Low: 0 ... 0,2 x U <sub>B</sub> [V DC] High: 0,6 x U <sub>B</sub> ... 30 V DC AC version: Low 0 ... 4 V DC High 12 ... 30 V DC
Pulse shape:	any shape (Schmitt-Trigger)
Output 1 Relay:	with potential-free contacts, programmable as normally-closed (NC) or normally-open (NO) switching voltage max. 250 V AC/125 V DC, switching current max. 3 A. switching current min. at DC 30 mA switching power max. DC 90 W max. AC 750 VA
or npn optocoupler:	with open collector and emitter switching power 30 V DC/15 mA
Output 2 Relay:	with potential free switching contact, programmable opening or closing.

	switching voltage max. 250 V AC/300 V DC, switching current max. 3 A. switching current at DC min. 30 mA switching power at DC 50 W at AC max. 2000 VA
or npn-optocoupler:	with open collector and emitter switching power 30 V DC/15 mA
Accuracy:	<0,1 % (at frequency meter mode) $\pm$ 50 ppm (at time counter mode)
Output response time:	Relay: approx. 7 ms Optocoupler: approx. 2 ms
Data storage:	min. 10 years or 10 <sup>8</sup> memory cycles
Transmitter voltage:	24 V DC -40 %/+15 %, 100 mA at AC version
Ambient temperature:	-10 ... +50 °C [14 ... 122 °F]
Storage temperature:	-25 ... +70 °C [-13 ... 158 °F]
EMC:	according to EC EMC directive 89/36/EWG
Emitted interference:	EN 61 000-6-4/EN 55011 class B
Immunity to interference:	EN 61 000-6-2
Protection:	IP 65 front side EX-proof IP54
Weight:	approx. 200 g [7.055 oz] Ex-execution 2 kg [70.548 oz]
only for EX proof:	Counter in EX proof version acc. to explosion-proof class EEx D IIC T6, with encapsulated cable 2 x 3 m [2.188 x 3.281 yards] PTB approval no. Ex-96.D. 1024 hardcoated AL-housing function mode as type 717 Note: the EX-proof version has an additional fuse.

### Inputs:

#### 2 counting inputs

The maximum frequency is 20 kHz (20 kHz in the phase discriminator mode); it can be reduced to 30 Hz.

#### Gate

##### Static gate input

pulse count mode: no counting, when the input is active  
timer mode: Counting when active gate.lo or not activated gate.hi programmable

#### Reset

Dynamic reset input with the same function as the reset key. Resets the counter to zero, when counting up and sets it to the preset value when counting down

#### Key

Static key lock input. The keys are locked as long as this input is on. The preselection display key remains active

### Interfaces:

The devices can be fitted with the optional RS 232, RS422 or with the RS 485 interfaces. These interfaces can be used to program the devices as well as for remote reading. They are simply controlled by ESC sequences, max. 4800 Baud

### Programming:

The counters 716/717 are programmed by means of the 4 front keys. The operator guidance on this display allows a simple and intuitive programming. All settings can be carried out by selecting the corresponding parameters in this menu.

The follow modes can be programmed

1. Pulse counter
2. Frequency meter
3. Time meter

### Programmable are:

#### Input polarity:

Positive (pnp) or negative (npn). The selection is valid for all inputs.

#### Pulse or time counting modes:

- adding with counting; start at 0
- subtracting with counting start at the preset (716) and at preselection 2 (717)
- adding with automatic reset when the preset (716) or the preset 2 (717) is reached
- subtracting with automatic positioning at the preset (716) or preset 2 (717) when 0 is reached

#### Input types in pulse counter mode:

- Cnt.Dir 1 counting input  
1 counting direction input
- uP.dn Differential counting  
1 adding input  
1 subtracting input

- quad Phase discriminator to connect encoders with 2 signals shifted by 90°
- quad2 Phase discriminator with double pulse processing, to connect pulse sources with 2 signals shifted by 90°

### Decimal places:

Data can be displayed with one, two or three decimal places

### Factor:

For an optimum matching of the measuring signal, the displayed values can be weighted by a scale factor between 0.0001 and 99.9999.

### Output signal:

The function of the output signal can be preselected (independently for both outputs of model 717) as a normally closed, normally open or a negative pulse signal.

### Maximum counting frequency:

The maximum counting frequency can be set to 30 Hz or 20 kHz.

### Timer:

Counting can be carried out in h, min, s or in h:min:s. The number of decimal places determines the resolution. A resolution up to the ms-range can be achieved.

### Connection diagram:

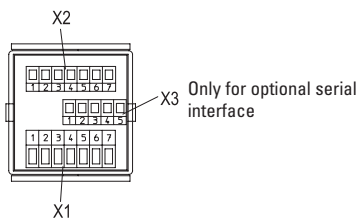

Pin connection X2:

Pin	Description	AC version	DC-Version
1	+24 V DC	Transmitter voltage	n.c.
2	0 V DC (GND)	GND	n.c.
3	INP A	Count input A	
4	INP B	Count input B	
5	Reset	Reset input	
6	Gate	Gate input	
7	Key	input for key lock	

Pin connection X1:

Pin	AC version	DC version
1	Output1 Relay Collector at Optocoupler output	
2	Output 1 Relay Emitter at Optocoupler output	
3	Output 2 Relay common contact (C) Emitter at Optocoupler output	
4	Output 2 Relay closing contact (NO)	
5	Output 2 Relay opening contact (NC) Collector at Optocoupler output	
6	Power supply 90 ... 250 V AC	10 ... 30 V DC
7	90 ... 250 V AC	0 V DC (GND)

Pin connection X3:

PIN No.	RS232	RS 422	RS 485
1	GND	—	—
2	RxD	RI+	DO/RI+
3	TxD	RI-	DO/RI-
4	RTS	DO+	—
5	CTS	DO-	—



- Easy parameter software for counter type 716/717 and process displays 55x.
- Upload and download function
- Monitor- and terminal program for easy diagnostic functions
- Online display of the measurement values
- German and English.

## Dimensions:

717

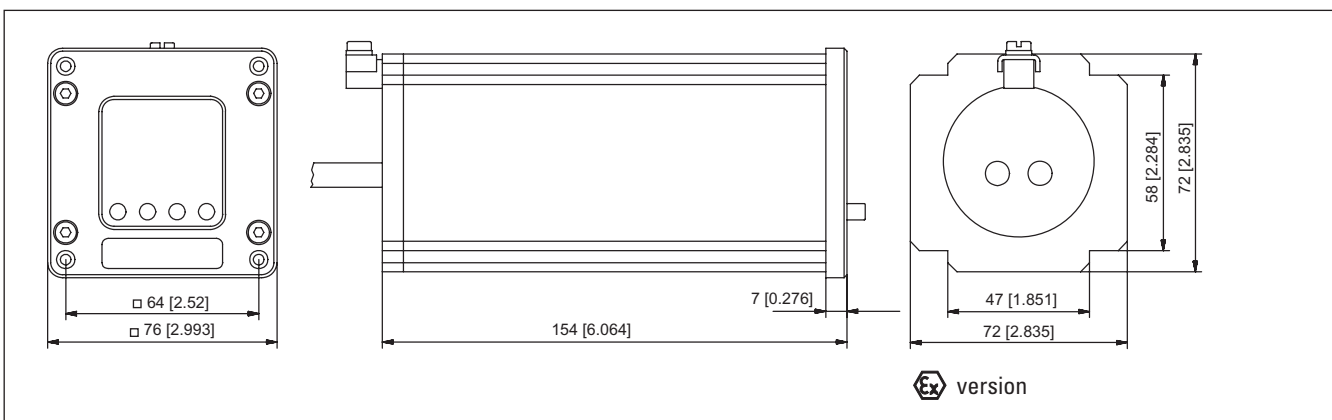
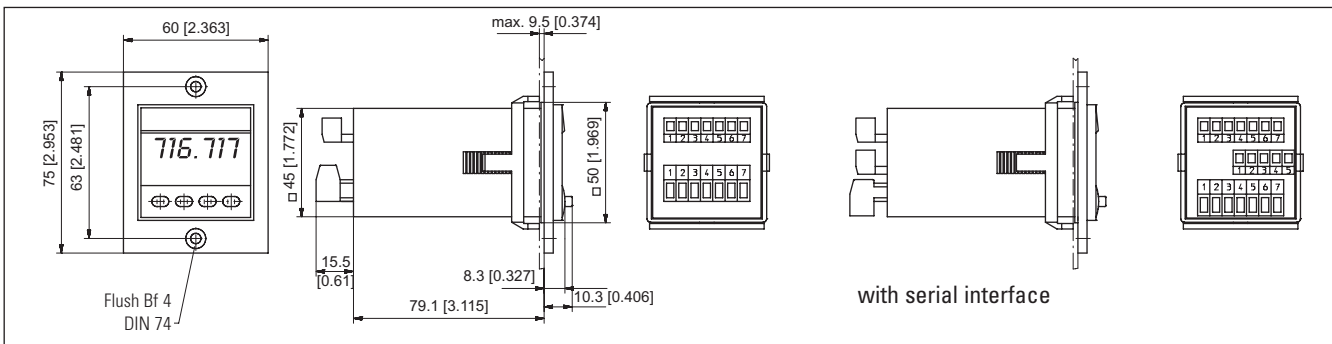
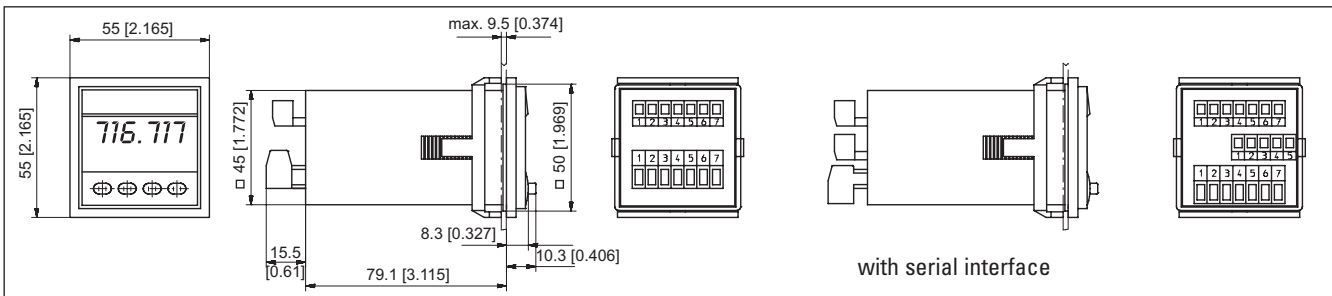
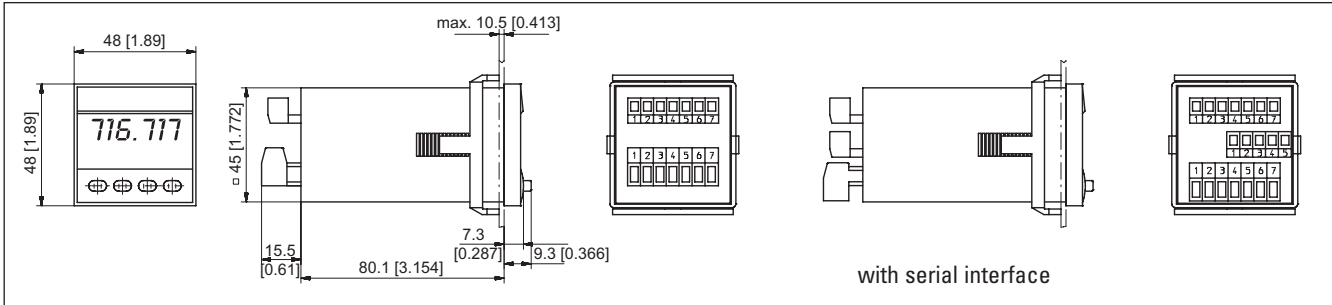

**Delivery includes: 716/717**

- |   |  |
|---|--|
| Counter 716/717   | 1 Bezel for clip mounting<br>panel cut-out 50 x 50 mm [1.969 x 1.969"] |
| 1 Screw terminal 7 pin, RM 5.08   | 1 Mounting clip  |
| 1 Screw terminal 7 pin, RM 3.81   | 1 Template for cut-out   |
| 1 Frame for screw mounting<br>panel cut-out 50 x 50 mm [1.969 x 1.969"] | 1 Operating instructions   |

**Order code:**

**6.71X.01X.XXX**

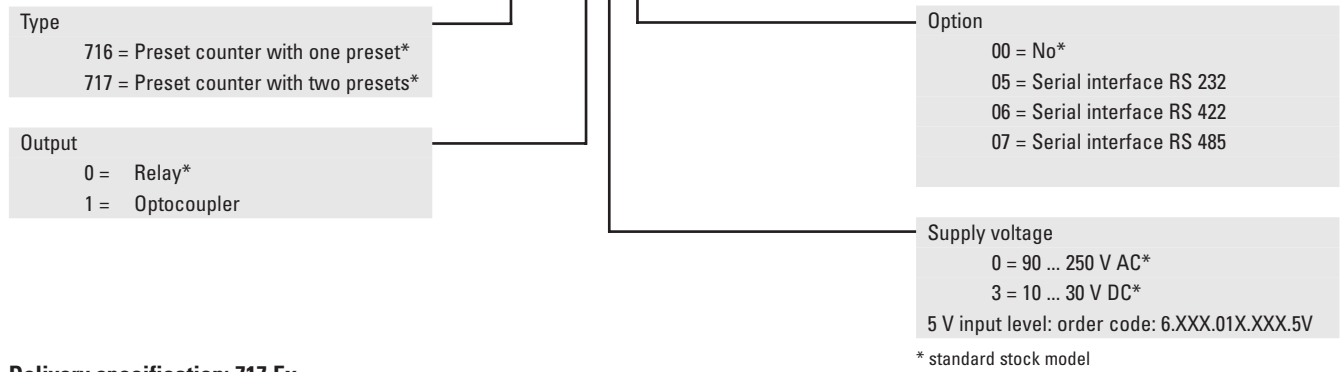

**Delivery specification: 717 Ex**

Counter 717 in Ex-proof housing acc. to explosion-proof class EEx D IIC T6 with encapsulated cable 2 x 3 m [2.188 x 3.281 yards], various mounting parts, PTB approval certificate

**Order code for Ex proof version:**

**6.717.010.X00.Ex**

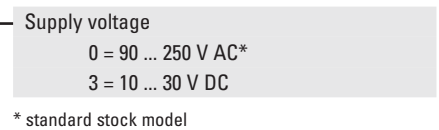

Timers

## Display Type 571



### Your benefit

- AC and DC supply voltage in one unit
- Measuring function can be programmed for RPM, speed (from elapsed time), machine cycle time, throughput and baking time (time interval), as well as numerous count and stop-watch functions
- Scalable display, programmed via 2 keys
- Large 15 mm [0.591"] high LED-display, 6-digit, with adjustable brightness

### Product features

- Fast count input, works with our **LIMES** measuring system (100KHz)
- Version with 2 optocoupler outputs for alarms
- Version with analogue output, resolution 14 Bit: 0 ... 10 V, +10 V ... -10 V, 0 ... 20 mA, 4 ... 20 mA
- Version with serial interface RS232/485 for importing and exporting data
- 48 x 96 mm [1.89 x 3.78"] DIN housing, IP 65

### Technical data:

Supply voltage:	16 ... 35 V DC (Normal voltage: 24 V DC) 115/230 V AC $\pm$ 12,5 %
Display:	15 mm [0.591"] high LED-display, 6 digits
Current consumption [DC]:	18 V: 120 mA; 24 V: 95 mA; 30 V: 80 mA
Power consumption [AC]:	7.5 VA
Sensor power supply:	24 V DC $\pm$ 15%, 120 mA (at AC and DC supply)
<b>Inputs:</b>	3 Inputs (PNP, NPN and Namur) A, B = Impulse, C = Reset
Max. input frequency:	A, B = 25 kHz (100 kHz at count); C = 1 kHz
(Accuracy:	$\pm$ 1 ppm $\pm$ 1 digit
Input level HTL:	Low: 0 ... 3,5 V High: 9 ... 35 V

<b>Outputs:</b>	
Analogue-Output: (0.571.012.E90)	0 ... +10 V, 0 ... -10 V and 0 ... 20 mA, 4 ... 20mA
Resolution:	14 Bit + Sign
Accuracy:	0,1 %
Optocoupler-Output: (0.571.011.E00)	5 ... 35 V DC/150 mA
Interface (0.571.012.E05)	RS232 and RS485 acc. to ISO 1745 Drivecom Protocol
Operating temperature:	0 ... +45 °C [32 °F ... 113 °F]
Storage temperature:	-25 ... +70 °C [-13 °F ... 158 °F]
Protection:	IP 65 front side
EMC:	according to EC EMC directive 89/36/EWG
Interference emission:	EN 50081-2/EN 55011 class B
Interference resistance:	EN 6100-6-2
Weight:	approx. 200 g [7.055 oz]

### Dimensions:

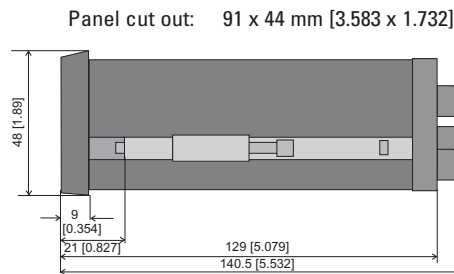
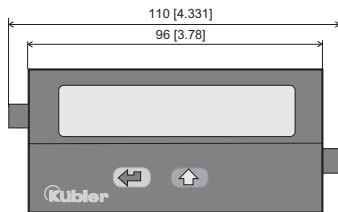

Panel cut out: 91 x 44 mm [3.583 x 1.732] Display with serial interface (0.571.012.E05)

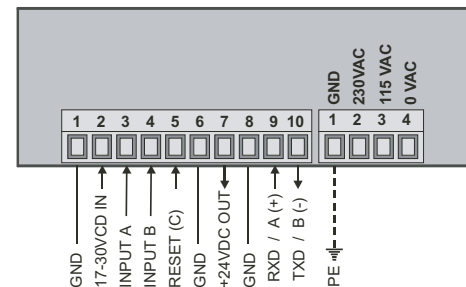

### Terminal assignment:

Display with analogue output (0.571.012.E90)

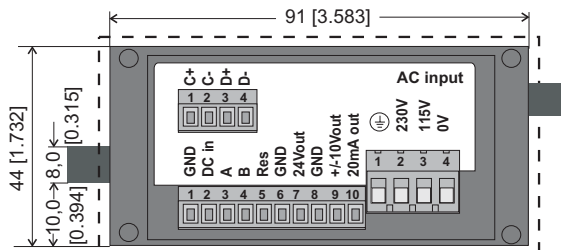

Display with 2 optocoupler outputs (0.571.011.E00)

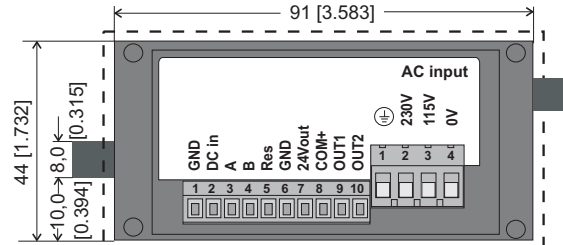

### Delivery specifications:

- Display 571
- Seal
- Mounting kit
- Plug-in screw terminals
- Manual German/English

### Order data:

- Display with 2 outputs Order code: 0.571.011.E00\*
- Display with analogue output Order code: 0.571.012.E90\*
- Display with ser. interface Order code: 0.571.012.E05

\* standard stock model



## Type series HVa 15



- 5-digit presettable hour meter with stationary preset value
- Manual reset
- High shock resistance
- Magnified figures
- Protection IP 42 (front)
- Data retention if power is lost
- Long service life

### Applications:

general counting,  
service interval for  
measurement systems  
(respiratory ventilators, oxygen  
machines, dialysis machines),  
small appliances, UV lamps,  
display panels in cars.

### Technical data:

Electrical connection:	Tin-plated round pins $\varnothing$ 1,6 mm [0.063"], with push on connectors
Power consumption:	10 ... 30 V DC: approx. 0.5 W 36 ... 80 V DC: approx. 0.9 W 100 ... 130 V DC: approx. 0.75 W 20 ... 30 V AC, 50 Hz: approx. 0.3 VA 42 ... 48 V AC, 50 Hz: approx. 0.25 VA 100 ... 130 V AC, 50 Hz: approx. 0.6 VA 187 ... 264 V AC, 50 Hz: approx. 1.2 VA 360 ... 440 V AC, 50 Hz: approx. 1.65 VA
Rated voltages:	20 ... 30/42 ... 48/100 ... 130/187 ... 264, 360 V AC 50 or 60 Hz, 10 ... 30/36 ... 80/100 ... 130 V DC
Range:	at AC: 999.99 h at DC: 9999.9 h
On time:	100 %
Count mode:	adding
Colour of figures:	Hour: white on black, 1/10 and 1/100 h: red on white Preset: approx. 4mm [0.158"] high Hour: yellow on black 1/10 and 1/100 h: red on white
Reset:	manual
Ambient temperature:	-15 ... +50 °C [5 ... 122 °F]
Mounting position:	any
Protection:	IP 42 front side, Sealing cover K1: IP 54 front side Clear cover Dv and Dvs: IP 55 front side

Colour of housing:	black, grey on request
Switching contact:	1 changeover contact (Micro switch) release at the preset time loading capacity at AC: max.250 V, max 2 A loading capacity at DC: 24 V max. 2.0 A 60 V max. 0.7 A ohmic load 115 V max. 0.4 A 230 V max. 0.2 A with inductive load, a spark quenching is required reducing the max. current to 65 %
Options:	Knob-locking 0-reset
Housing:	black: Art. no. 3.30X.X17.XXX grey: Art. no. 3.30X.X16.XXX HVa 15.01 (without front bezel) pluggable in socket box 946.1 DIN Rail mount SR 3
Housing:	black: Art. no. 3.300.001.XXX beige: Art. no. 3.300.012.XXX
Test voltage:	2000 VA C, 50 Hz at AC
Sealing:	oil and gasoline-resistant synthetic rubber, particularly suitable for use with acids and alkalis, very good age stability.
Accessories:	Socket box 946.1 Art. no. G.008.439
Front frame:	black: Art. no. G.007.504 beige: Art. no. G.007.503

### HVa 15.11

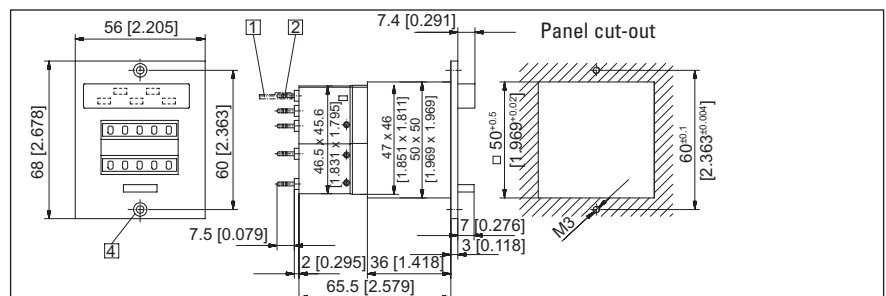

Voltage	Art-No. (AC), 50 Hz	Art-No. (AC), 60 Hz	Art-No. (V DC)
10 ... 30			3.300.111.351
20 ... 30	3.300.111.071	3.300.111.081	
36 ... 80			3.300.111.353
42 ... 48	3.300.111.072	3.300.111.082	
100 ... 130	3.300.111.074	3.300.111.084	3.300.111.381
187 ... 264	3.300.111.075	3.300.111.085	
360 ... 440	3.300.111.079	3.300.111.089	

- 1 Tin plated push on connector
- 2 Round pin  $\varnothing$  1.5 [0.059"] tin plated
- 4 Countersink Af34 DIN 74

## HVa 15.21

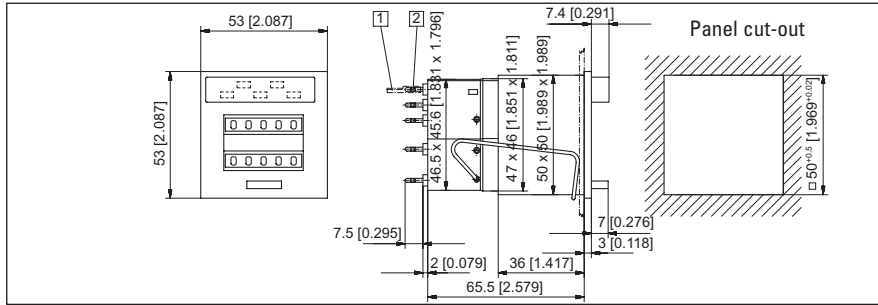

Voltage	Art-No. (AC), 50 Hz	Art-No. (AC), 60 Hz	Art-No. (V DC)
10 ... 30			3.300.211.351
20 ... 30	3.300.211.071	3.300.211.081	
36 ... 80			3.300.211.353
42 ... 48	3.300.211.072	3.300.211.082	
100 ... 130	3.300.211.074	3.300.211.084	3.300.211.381
187 ... 264	3.300.211.075	3.300.211.085	
360 ... 440	3.300.211.079	3.300.211.089	

- 1 Tin plated push on connector  $\varnothing$  1.5 [0.059"]
- 2 Tin plated round pin  $\varnothing$  1.5 [0.059"]

## HVa 15.31

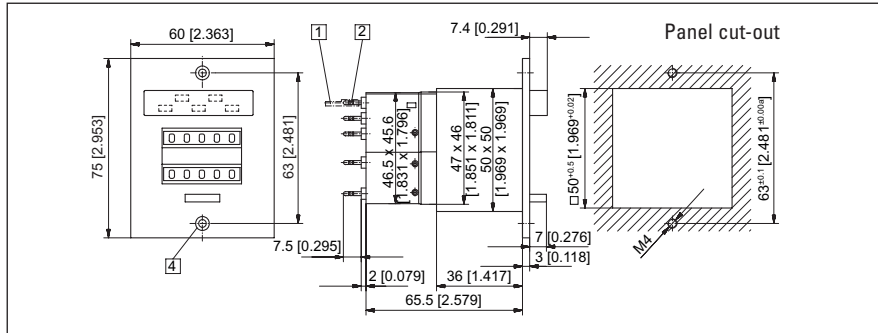

Voltage	Art-No. (AC), 50 Hz	Art-No. (AC), 60 Hz	Art-No. (V DC)
10 ... 30			3.300.311.351
20 ... 30	3.300.311.071	3.300.311.081	
36 ... 80			3.300.311.353
42 ... 48	3.300.311.072	3.300.311.082	
100 ... 130	3.300.311.074	3.300.311.084	3.300.311.381
187 ... 264	3.300.311.075	3.300.311.085	
360 ... 440	3.300.311.079	3.300.311.089	

- 1 Tin plated push on connector  $\varnothing$  1.5 [0.059"]
- 2 Tin plated round pin  $\varnothing$  1.5 [0.059"]
- 3 Counter sink Af3 DIN 74

## K2 HVa 15.31

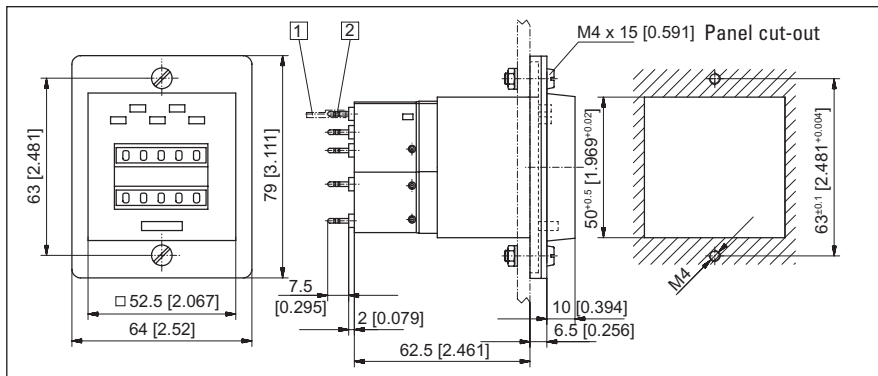

Voltage	Art-No. (AC), 50 Hz	Art-No. (AC), 60 Hz	Art-No. (V DC)
10 ... 30			3.300.611.351
20 ... 30	3.300.611.071	3.300.611.081	
36 ... 80			3.300.611.353
42 ... 48	3.300.611.072	3.300.611.082	
100 ... 130	3.300.611.074	3.300.611.084	3.300.611.381
187 ... 264	3.300.611.075	3.300.611.085	
360 ... 440	3.300.611.079	3.300.611.089	

- 1 Tin plated push on connector  $\varnothing$  1.5 [0.059"]
- 2 Tin plated round pin  $\varnothing$  1.5 [0.059"]

## Dv HVa 15.31 (knob locking cover)

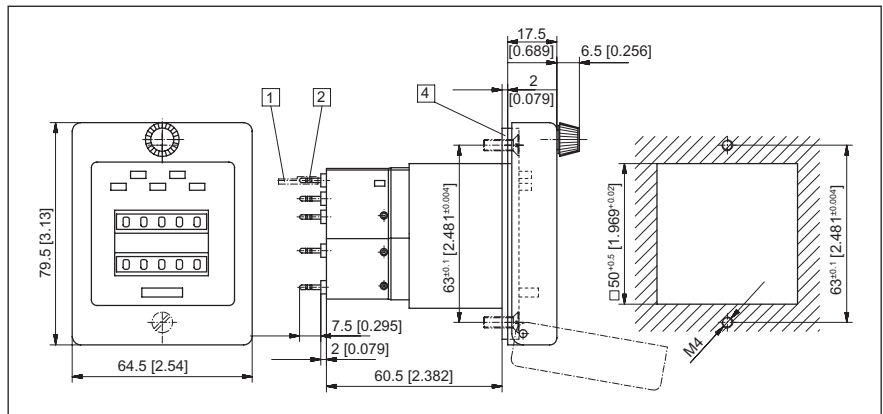

Voltage	Art-No. (AC), 50 Hz	Art-No. (AC), 60 Hz	Art-No. (V DC)
10 ... 30			3.300.711.351
20 ... 30	3.300.711.071	3.300.711.081	
36 ... 80			3.300.711.353
42 ... 48	3.300.711.072	3.300.711.082	
100 ... 130	3.300.711.074	3.300.711.084	3.300.711.381
187 ... 264	3.300.711.075	3.300.711.085	
360 ... 440	3.300.711.079	3.300.711.089	

- 1 Tin plated push on connector  $\varnothing$  1.5 [0.059"]
- 2 Tin plated round pin  $\varnothing$  1.5 [0.059"]
- 4 Sealing

## Dvs HVa 15.31 (locking transparent cover)

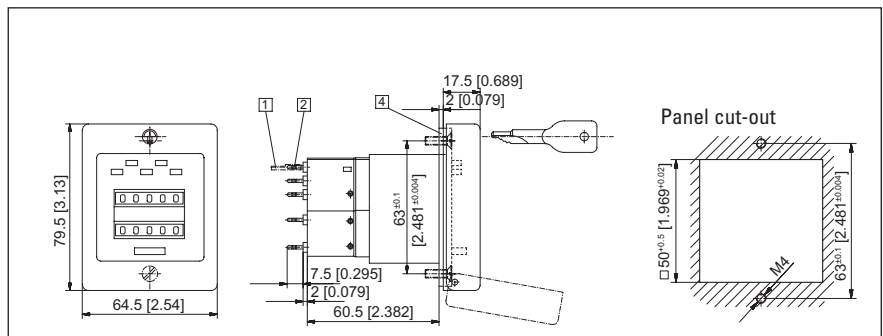

Voltage	Art-No. (AC), 50 Hz	Art-No. (AC), 60 Hz	Art-No. (V DC)
10 ... 30			3.300.811.351
20 ... 30	3.300.811.071	3.300.811.081	
36 ... 80			3.300.811.353
42 ... 48	3.300.811.072	3.300.811.082	
100 ... 130	3.300.811.074	3.300.811.084	3.300.811.381
187 ... 264	3.300.811.075	3.300.811.085	
360 ... 440	3.300.811.079	3.300.811.089	

- 1 Tin plated push on connector  $\varnothing$  1.5 [0.059"]
- 2 Tin plated round pin  $\varnothing$  1.5 [0.059"]
- 4 Sealing

## Wiring diagrams:

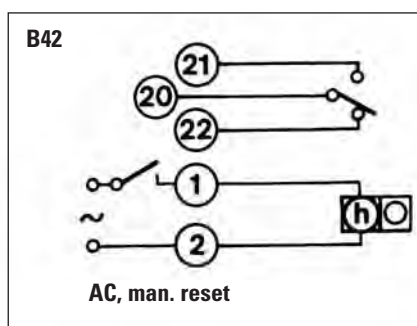
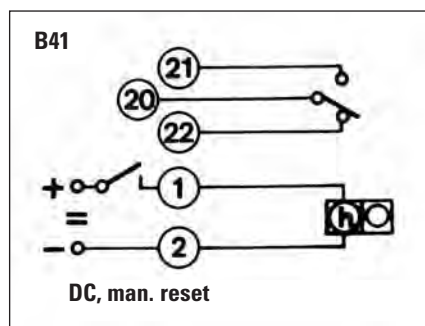

## Time Relay Type 910



- Easy to operate using over decade keyboard
- No external voltage supply, because of internal replaceable lithium battery
- High contrast, 2-line LCD-Display, 5-digit, with many symbols for easy operation and reading
- 9 programmable time ranges from 0.20 seconds up to 99 999 hours
- Resolution up to 0.01 seconds
- Inputs for start and reset
  - universal inputs for 12 ... 260 V AC/DC
- 8 timing modes
  - ON Delay, OFF Delay, One shot and Single Shot
  - Repeat cycle modes: Delay, Cycle, Symmetrical delay
- 3 programmable activation modes
- Relay contacts rated at 8 A programmable to NO or NC
- Protection IP 65
- Plug-in connector

### Technical data:

Voltage supply:	2 x 3 V ½AA replaceable lithium batteries, service life > 10 years or 500 000 relay changes
Timing and Reset inputs:	12 ... 260 V AC/DC, impedance 180 kΩ min. impulse 20 ms, (optocoupler)
Display (time):	5-digit LCD-Display; 6.5 mm [0.256"] high
(set time, mode)	5-digit LCD-Display; 3.5 mm [0.138"] high
Accuracy:	+50/–20 ms respectively 0,5 % of setting time (higher value counts)
Repetition accuracy:	0.3 % of setting time
Operating temperature:	–10 ... +60 °C [14 ... 140 °F]
Storage temperature:	–20 ... +70 °C [–4 ... 158 °F]
Relative humidity:	80 % max. up to 31 °C [87.8 °F]; decreasing to max. 50 % at 40 °C [104 °F]
Protection:	IP 65 with delivered seal

### Output relays

Contact connection:	SPTST voltage free contacts programmable as NO or NC
Contact capacitance:	250 V AC at 8 A; cos φ = 1 250 V AC at 5 A; cos φ = 0,4 30 V DC at 8 A; cos φ = 1
Reaction time:	< 20 ms
Expected life:	2 A ohmic load 1 000 000 switching cycles
EMC:	CE-conform to EC-guideline 89/36/EWG
Electromagnetic radiation:	EN 61 000-6-4/EN 55 011 class B
Electromagnetic immunity:	EN 61 000-6-2
Weight:	approx. 80 g [2.822 oz]

### Time ranges

1 s ... 99999 s; 0.2 s ... 9999.9 s; 0.02 ... 999.99s;  
1 min ... 99999 min; 0,1 min ... 9999.9 min; 0.01 min ... 999.99 min;  
1 h ... 99999 h; 0.1 h ... 9999.9 h; 0.01 h ... 999.99 h

### Dimensions:

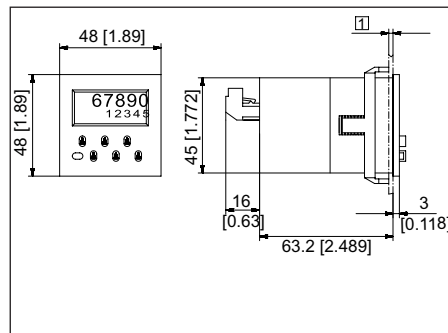

1 Max. 10,5 [0.413]  
at front panel 3  
max. 9.5 [0.374]

Panel cut-out:  
45<sup>+0,6</sup> x 45<sup>+0,6</sup> mm  
[1.722<sup>+0,024</sup> x 1.772<sup>+0,024</sup>]

### Connections:

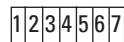

1	Common for terminals 2 + 3	
2	Timing input, programmable as level or edge triggered	These inputs can be 12 ... 260 V AC/DC. For DC input the polarity is unimportant
3	Reset input	
4/5	Voltage free relay contacts, programmable as NO or NC	
6/7	Connect together to disable front panel keys	

### Timing modes:

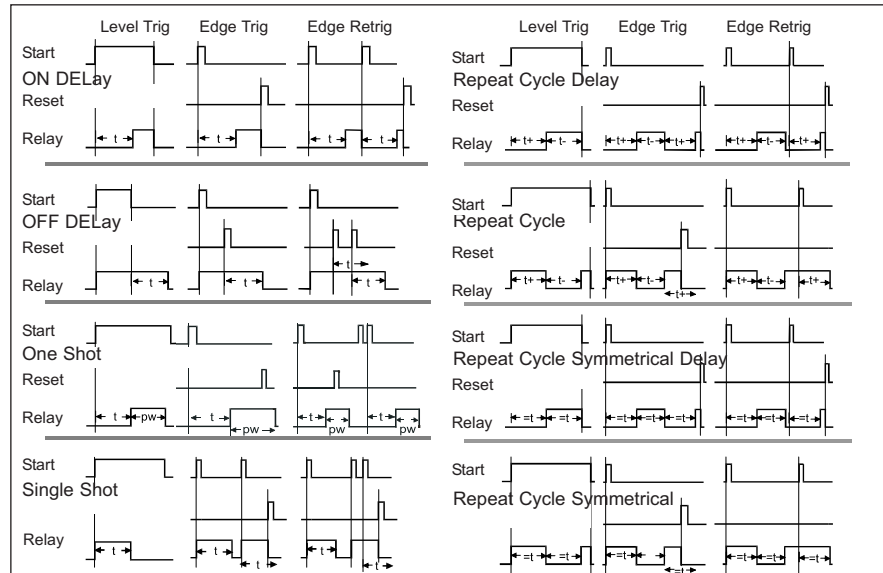

### Order code:

Order-No.: 0.910.010.800 (standard stock model)

### Delivery specification:

Time relay, seal, clamp, user manual multilingual, front panel 3 for screw mounting, mounting dimensions 60 x 75 mm, [2.363 x 2.953"] front panel 2 for clamping mounting dimensions 55 x 55 mm [2.166 x 2.166"], template for panel cut-out (50 x 50 mm [1.969 x 1.969"] for front panel 2 and 3).

## Table of Contents

Type of counter	Series	Display	Panel cut-out W x H [mm]	Reset			Remarks	Page	
				without	man.	electr.			
Tachometer Frequency meters	LCD	Codix 136	12000	45 x 22	–	–	–	Panel mount, tachometer	230
	LED	Codix 522	999999	45 x 22	–	–	–	Panel mount, tachometer	232
		Codix 524	999999	45 x 22	–	•	•	Multifunction	234
		Codix 52U	999999	45 x 22	–	•	•	Universal with dual functions	236
		Codix 52P	999999	45 x 22	–	•	•	Position- and frequency display	238
		Codix 542	999999	92 x 45	–	–	–	Panel mount, tachometer	240
		Codix 544	999999	92 x 45	–	•	•	Multifunction	242
		Codix 54U	999999	92 x 45	–	•	•	Universal with dual functions	244
		Codix 54P	999999	92 x 45	–	•	•	Position- and frequency display	246
Tachometer / Frequency meter with limits	LCD	923/924	999999	92 x 45	–	•	•	Panel mout AC- or DC supply	230
		903/904	999999	45 x 45	–	•	•	Panel mount, AC or DC-supply	254
	LED	715	99999	45 x 45	–	•	•	Panel mount, AC or DC-supply	257
		Codix 716/717	999999	45 x 45	–	•	•	Panel mount , also with Ex or interface	260
		571	999999	92 x 45	–	•	•	Panel mount, multifunction	264

## LCD-Frequency meter/Tachometer **CODIX 136**



- Low-price and high efficiency
- Large 8-digit LCD display, height of the figures 8 mm [0.315"]
- Optional backlighting
- Input frequency range from 1 Hz ... 12 kHz
- Gate measuring method, gate time 1 second
- Accuracy 0.05%
- All versions for positive or negative counting edge
- Unified Codix design, suiting the extensive **CODIX** family
- IP 65
- Screw terminals, RM 5 mm [0.197"]
- Lifetime of the battery approximately 8 years
- Frequency measurement without external voltage supply, pulses acquisition also possible via dry contact, thus usable in all conditions
- Ambient temperature -10 ... +60 °C [14 ... 140 °F]

### Technical data:

Power supply:	non-replaceable lithium battery: (lifetime approximately 8 years at 20 °C [68 °F])
Backlighting:	external electrical source 24 V DC +/-20 %, 50 mA
Display:	LCD, 8 decades, height of the figures 8mm [0.315"]
Display range:	0 ... 99999999
Resolution:	1/sec (1 Hz)
Counting inputs:	
A. Counting input of the DC-versions (max. 30 V DC)	
Slow counting input:	max. 30 Hz NPN
Fast counting input:	max. 12 kHz (PNP), 7 kHz (NPN)
Switching level:	NPN: Low: 0 ... 0.7 V, High: 4 ... 30 V DC PNP: Low: 0 ... 0.7 V, High: 4 ... 30 V DC

Interference emission:	EN 55011 Class B, EN 61000-6-2 EN 61010 Section 1 (only AC versions)
Housing:	dark grey RAL 7021
Operating temperature:	-10 ... +55 °C [14 ... 131 °F]
Ambient temperature:	-10 ... +60 °C [14 ... 140 °F]
Storage temperature:	-20 ... +70 °C [-4 ... 158 °F]
Protection:	IP 65 front side
Weight:	approx. 50 g [1.764 oz]

### Connecting diagram:

DC type:  
6.136.012.8x0

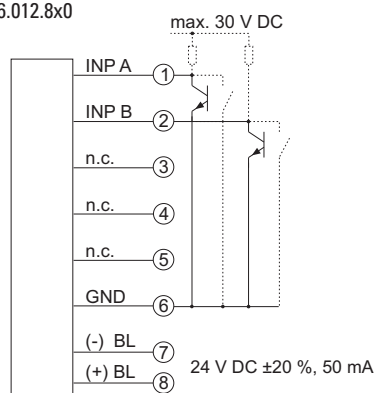

DC type:  
6.136.012.8x1

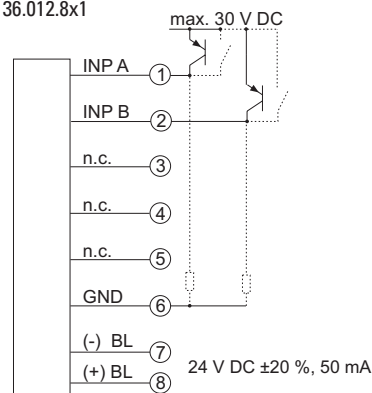

**Dimensions:**

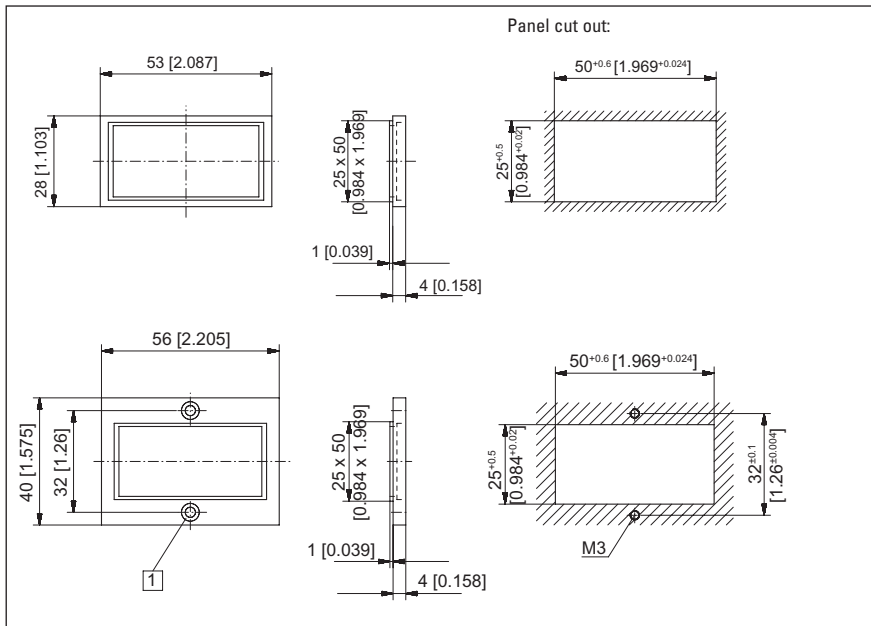
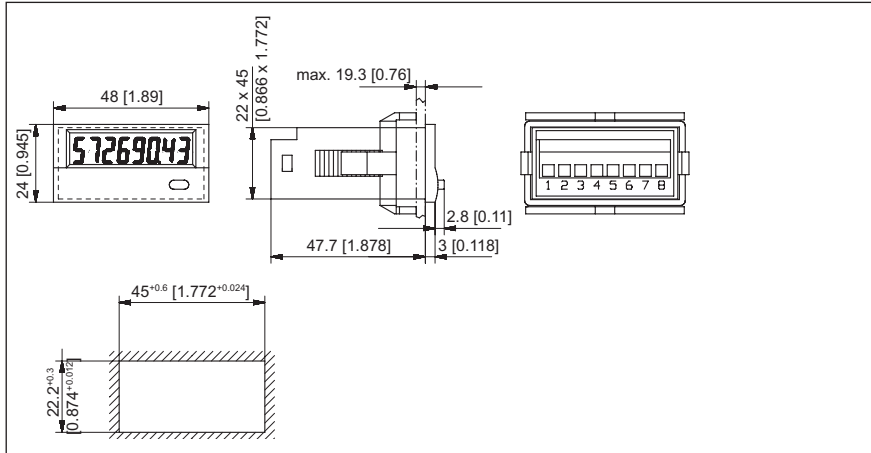

1 Countersunk Af3, DIN 74

**Delivery specification:**

- Digital display
- Panel mounting clip
- Bezel for screw mounting 56 x 40 mm [2.205 x 1.575"], panel cut out 50 x 25 mm [1.969 x 0.984"]
- Bezel for clip mounting 53 x 28 mm [2.087 x 1.103"], panel cut out 50 x 25 mm [1.969 x 0.984"]
- Seal
- Operating instructions

**Order code:**

Type	Mode	Counting inputs					
		INP A			INP B		
6.136.012.8x0*	Tacho	0 ... 0.7 V DC	NPN	7 kHz	0 ... 0,7 V DC	NPN	30 Hz
6.136.012.8x1*	Tacho	4 ... 30 V DC	PNP	12 kHz	4 ... 30 V DC	PNP	30 Hz

X: 5 = No backlight      \*standard stock model  
 X: 6 = With backlight

## Frequency meter/Tachometer **CODIX 522**

- Fast High Rate Accuracy System (HRA)
- Display scaleable 1/min or 1/sec

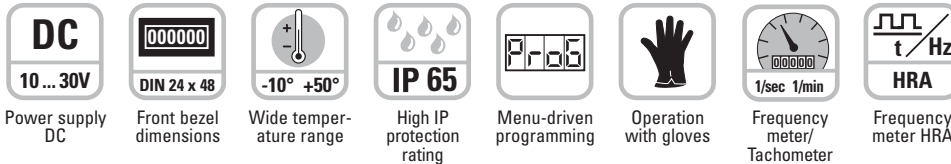

### Powerful

- **Fast count input**  
Input frequency max. 60 kHz
- **Robust housing**  
IP 65 protection
- **LED display**  
Very bright, 8 mm high
- **HRA – High Rate Accuracy System**  
Frequencies up to 38 Hz are calculated using time-interval (period duration) measurement. Frequencies > 38 Hz are calculated using a special time base (gate time) measurement. A very high accuracy of > 0.1% is achieved, even with very short gate times. The resulting measurement is available after a max. of 50 ms.
- **Fast start-up time**  
Detects incoming pulses just 16 ms after being switched on – so no pulses are lost with a simultaneous motor start-up



### User-friendly

- **Big keys**  
Can also be operated when using gloves
- **Easy to programme**  
Easy menu-driven programming and operation  
Possibility to enter the programming mode during operation, with authentication query

### Universal

- **Individually programmable scaling**  
Multiplication and division factor (0.0001 to 99.9999), to display corresponding engineering units, e.g. position in 1/10 mm and speed in RPM
- **Programmable decimal point**  
Can be set between 0.0 and 0.000 – this determines the resolution
- **Programmable delay until 0 is displayed**
- **Display in 1/min or 1/sec**
- **DC power supply**
- **Inputs**  
As an alternative to the HTL inputs, devices with a 5 VDC input trigger level are available, for use as parallel displays for PLCs
- **Optional output**  
For zero-speed monitoring

### Applications for Speed and Frequency Displays

- Rotary speed applications, e.g. OEM equipment or retrofitting to drilling machines
- OEM equipment for flow rate measuring, e.g. current flow rate; production data such as volume/time
- Speed applications on motors, turbines, machines; feed-rate measurement
- Recording of production rates
- Frequency measurement

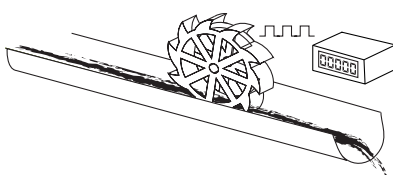

Mass flow rate

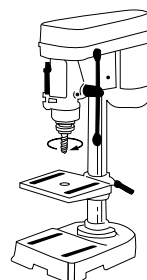

Drilling machine head, rotary speed

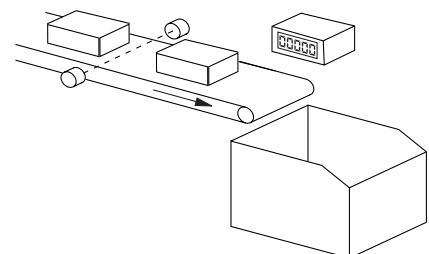

Production rate



## Frequency meter/Tachometer CODIX 522

### Technical data:

Power supply:	10 ... 30 V DC, with reverse polarity protection	Level of the inputs:	Low: 0 ... 0.2 x U <sub>B</sub> [V DC] High: 0.6 x U <sub>B</sub> ... 30 V DC
Current consumption:	max. 50 mA	Optocoupler output:	Max. 30 V, 10 mA
Display:	6-digit 7-segment red LED display; figures 8 mm [0.315"] high	Accuracy:	<0.1 %
Data retention:	EEPROM	Ambient temperature:	-10 ... +50 °C [14 ... 122 °F] non-condensing
Housing:	Dimensions 48 x 24 mm [1.89 x 0.945"] according to DIN 43 700; RAL 7021, grey	Storage temperature:	-25 ... +70 °C [-13 ... 158 °F]
Polarity of the inputs:	programmable, npn or pnp	EMC:	according to EC EMC directive 89/36/EWG
Input resistance:	approx. 5 kΩ	Interference emission:	EN 61000-6-4/EN 55011 class B
Count frequency:	60 kHz, can be damped to 30 Hz	Interference resistance:	EN 61000-6-2
Measurement principle:	Period duration measurement with averaging at higher frequencies	Protection:	IP 65 front side
		Weight:	approx. 50 g [1.764 oz]

### Block diagram:

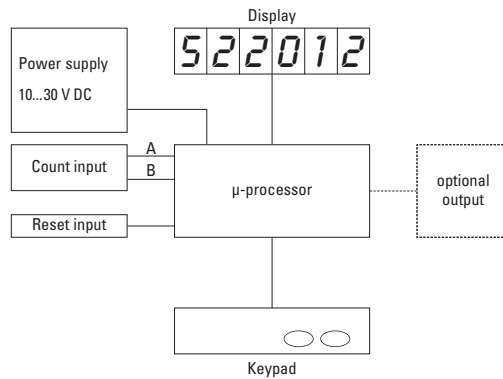

### Dimensions:

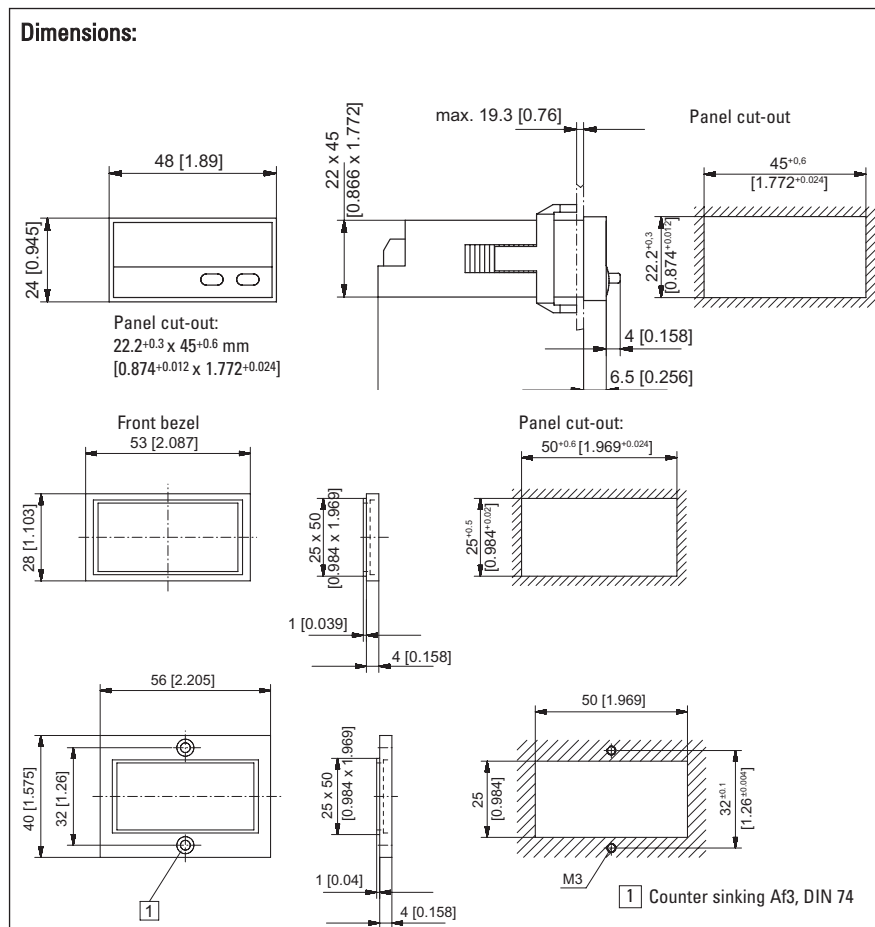

### Connection:

without optocoupler

- 1 10 ... 30 V DC
- 2 0 V GND
- 3 INP
- 4 -
- 5 -

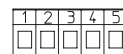

### Connection:

with optocoupler (npn)

- 1 10 ... 30 V DC
- 2 0 V GND
- 3 INP
- 4 -
- 5 -
- 6 Emitter
- 7 Collector

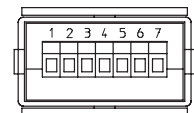

### Delivery specification:

- 1 Digital display
- 1 Panel mounting clip
- 1 Bezel for screw mounting, panel cut out 50 x 25 mm [1.969 x 0.984"]
- 1 Bezel for clip mounting, panel cut out 50 x 25 mm [1.969 x 0.984"]
- 1 Seal
- 1 Multilingual operating instructions

### Order code:

6.522.01X.3X0

- Input switching level
  - 0 = standard\*
  - A = 5 V
- Output
  - 1 = Optocoupler output
  - 2 = No output\*

\*standard stock model

## Multifunction display **CODIX 524**

programmable as:

- Pulse counter
- Position display
- Frequency / speed display
- Timer/ short time meter

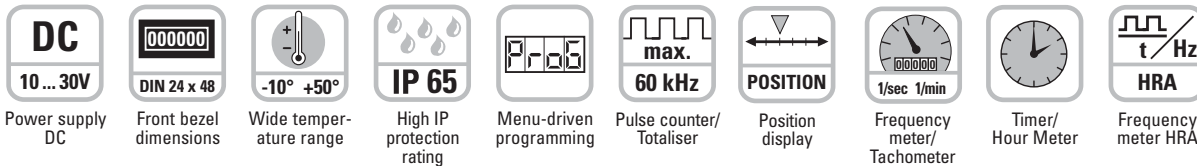

### Powerful

- **Fast count input**  
Input frequency max. 60 kHz
- **Robust housing**  
IP 65 protection
- **LED display**  
Very bright, 8 mm high
- **HRA – High Rate Accuracy System**  
Frequencies up to 38 Hz are calculated using time-interval (period duration) measurement.  
Frequencies > 38 Hz are calculated using a special time base (gate time) measurement. A very high accuracy of > 0.1% is achieved, even with very short gate times. The resulting measurement is available after a max. of 50 ms.
- **Fast start-up time**  
Detects incoming pulses just 16 ms after being switched on – so no pulses are lost with a simultaneous motor start-up



### User-friendly

- **Big keys**  
Can also be operated when using gloves
- **Easy to programme**  
Easy menu-driven programming and operation  
Possibility to enter the programming mode during operation, with authentication query

### Universal

- **Individually programmable scaling**  
Multiplication and division factor (0.0001 to 99.9999), to display corresponding engineering units, e.g. position in 1/10 mm and speed in RPM.
- **4 different count input modes**  
2-channel input for detecting count direction, difference or adding mode, quadrature x1, x2 or x4
- **Frequency measurement**  
Display in 1/min or 1/sec
- **Time counting**  
Pulse width or time interval measurement in hours, minutes or seconds, as well as real-time display
- **DC power supply**
- **Inputs**  
As an alternative to the HTL inputs, devices with a 5 VDC input trigger level are available, for use as parallel displays for PLCs
- **Optional output**  
Zero signal for position and count, zero-speed monitoring, 1 Hz clock pulse for active time measurement

### Applications for Multi-function Display

- Counting tasks such as quantity and piece counting, measuring and recording of speed and of operating and processing times
- Piece counting or tool-life measurement on die cutters, presses, extruders, wood-working machines, drilling machines,

- pick-and-place machines, guillotines, special-purpose vehicles etc.
- Positioning tasks on processing machines, such as sawing machines, milling machines, bending and folding machines, etc.

- Production data acquisition by means of piece counting (using difference or adding), or measurement of production times or production speeds.
- Totalizing flow, quantity and other scaleable media, or display of current flow rates.

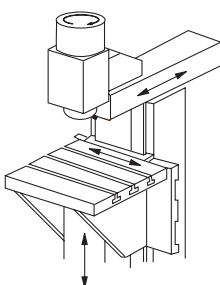

Position or rotary speed on milling machine

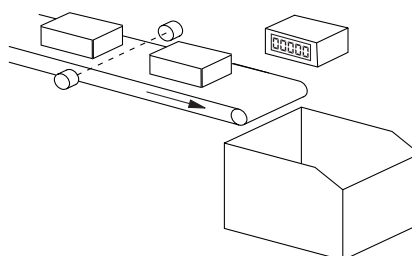

Piece count on conveyor or production speed

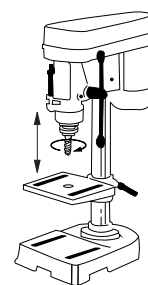

Drilling machine head, speed or drilling depth

## Multifunction display *CODIX 524*

### Technical data:

Supply voltage:	10 ... 30 V DC, with reverse polarity protection	Level of inputs:	Low: 0 ... 0.2 x U <sub>B</sub> [V DC] High: 0.6 x U <sub>B</sub> ... 30 V DC
Current consumption:	max. 50 mA	Level of inputs:	Low: 0 ... 2 V DC High: 4 ... 30 V DC
Display:	6-digit 7-segment red LED; 8 mm [0.315"] high	5 V version	High: 4 ... 30 V DC
Data backup:	EEPROM	Optocoupler output:	Max. 30 V, 10 mA
Housing:	Dimension 48 x 24 mm [1.89 x 0.945"] according to DIN 43 700; RAL 7021, grey	Accuracy:	Tachometer: <0.1 % Timer: 50 ppm
Polarity of inputs:	programmable, npn or pnp for all inputs	EMC:	according to EC EMC directive 89/36/EWG
Input resistance:	approx. 5 kΩ	Emitted interference:	EN 61000-6-4/EN 55011 class B
Counting frequency:	60 kHz, can be damped to 30 Hz	Immunity to interference:	EN 61000-6-2
Display range timer:	0.001 s ... 999999 h	Ambient temperature:	-10 ... +50 °C [14 ... 122 °F]
Reset time:	5 ms	Storage temperature:	-25 ... +70 °C [-13 ... 158 °F]
		Protection:	IP 65 front side
		Weight:	approx. 50 g [1.764 oz]

### Block diagram:

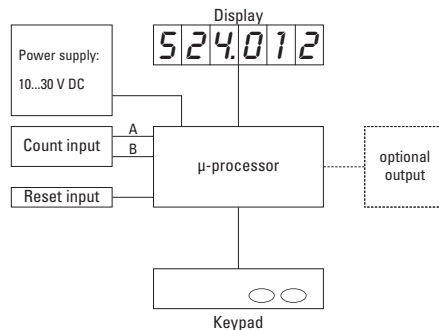

### Dimensions:

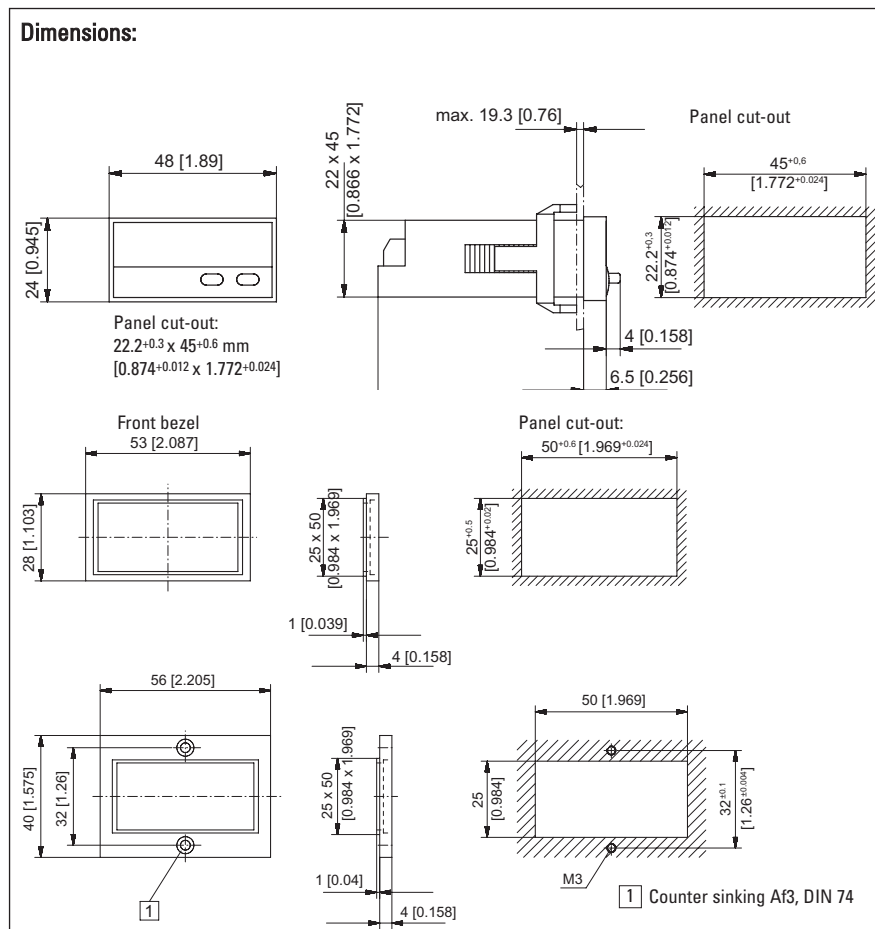

### Connections:

without optocoupler

- 1 10 ... 30 V DC
- 2 0 V GND
- 3 INP A
- 4 INP B
- 5 Reset

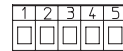

### Connections:

with optocoupler

- 1 10 ... 30 V DC
- 2 0 V GND
- 3 INP A
- 4 INP B
- 5 RESET
- 6 Emitter
- 7 Collector

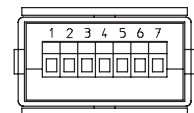

### Delivery specifications:

- 1 Digital display
- 1 Panel mounting clip
- 1 Bezel for screw mounting, panel cut out 50 x 25 mm [1.969 x 0.984"]
- 1 Bezel for clip mounting, panel cut out 50 x 25 mm [1.969 x 0.984"]
- 1 Seal
- 1 Multilingual operating instructions

### Order code:

6.524.01X.3X0

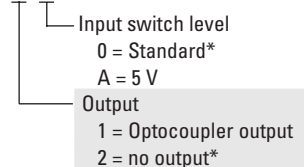

\* standard stock model

## Universal with dual functions **CODIX 52U**

**4 dual functions in one device**  
 > solves all applications where 2 different values must be displayed simultaneously.

- Counter with 2 totalizing ranges
- Totaliser and time counter
- Totaliser and frequency counter
- Timer with 2 time ranges

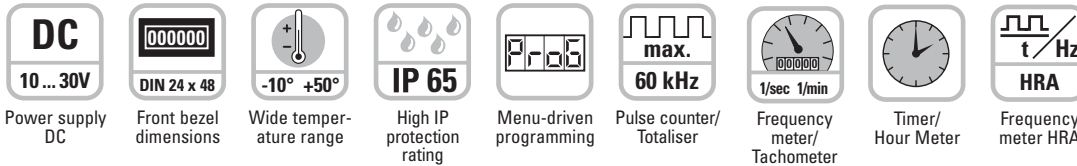

### Powerful

- **Fast count input**  
Input frequency max. 60 kHz
- **Robust housing**  
IP 65 protection
- **LED display**  
Very bright, 8 mm high
- **HRA – High Rate Accuracy System**  
Frequencies up to 38 Hz are calculated using time-interval (period duration) measurement.  
Frequencies > 38 Hz are calculated using a special time base (gate time) measurement. A very high accuracy of > 0.1% is achieved, even with very short gate times. The resulting measurement is available after a max. of 50 ms.
- **Fast start-up time**  
Detects incoming pulses just 16 ms after being switched on – so no pulses are lost with a simultaneous motor start-up



### User-friendly

- **Big keys**  
Can also be operated when using gloves
- **Easy to programme**  
Easy menu-driven programming and operation  
Possibility to enter the programming mode during operation, with authentication query  
Pressing the right key switches between displays

### Universal

- **Individually programmable scaling**  
Multiplication and division factor (0.0001 to 99.9999), to display corresponding engineering units, e.g. position in 1/10 mm and speed in RPM
- **Separate factors for frequency- and pulse counting**
- **DC power supply**
- **Inputs**  
As an alternative to the HTL inputs, devices with a 5 VDC input trigger level are available, for use as parallel displays for PLCs
- **Timer specials**  
Timer or hours-run meter with various Start Stop measurements, time range settings in hours, minutes or seconds, with decimal point. Resolutions up to 1/1000 can be programmed

### Applications for dual functions

- **Pulse and frequency (speed)**  
e.g. production data acquisition: total piece count and speed on OEM equipment, flow rate measuring systems – total flow and current flow
- **2 pulse counters**  
Measurement of batch and total piece count, or of daily production count and total count values

- **Pulse and time (Maintenance counter)**  
Used in the lift industry as trip counters and hours-run meters and on production machines for piece and time counting, flow and time measurement, materials handling time and quantities

- **2 timers**  
Measurement of total time and order-specific times, maintenance intervals and total time, time of day and total time

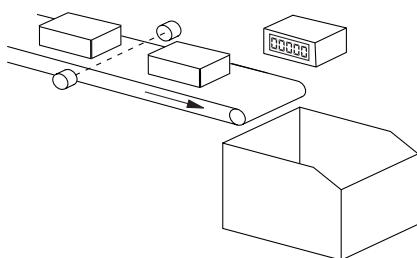

Cut-to-length  
Piece count and speed

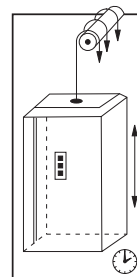

Trip counter and hours-run

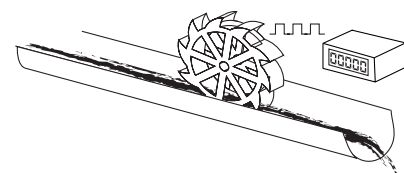

Flow rate and total volume

## Universal with dual functions **CODIX 52U**

### Technical data:

Supply voltage:	10 ... 30 V DC, with reverse polarity protection	Level of inputs:	Low: 0 ... 0.2 x U <sub>B</sub> [V DC] High: 0.6 x U <sub>B</sub> ... 30 V DC
Current consumption:	max. 40 mA	Level of inputs:	Low: 0 ... 2 V DC High: 4 ... 30 V DC
Display:	6-digit 7-segment red LED; 8 mm [0.315"] high	5 V version	High: 4 ... 30 V DC
Data backup:	EEPROM	Optocoupler output:	Max. 30 V, 10 mA
Housing:	Dimension 48 x 24 mm [1.89 x 0.945"] according to DIN 43 700; RAL 7021, grey	Accuracy:	<0.1 % (Frequency display, tachometer)
Polarity of inputs:	programmable, npn or pnp for all inputs	EMC:	according to EC EMC directive 89/36/EWG
Input resistance:	approx. 5 kΩ	Emitted interference:	EN 61000-6-4/EN 55011 class B
Counting frequency:	60 kHz, can be damped to 30 Hz	Immunity to interference:	EN 61000-6-2
Reset time:	5 ms	Ambient temperature:	-10 ... +50 °C [14 ... 122 °F]
Display range:	0.001 s ... 999999 h	Storage temperature:	-25 ... +70 °C [-13 ... 158 °F]
		Protection:	IP 65 front side
		Weight:	approx. 50 g [1.764 oz]

### Block diagram:

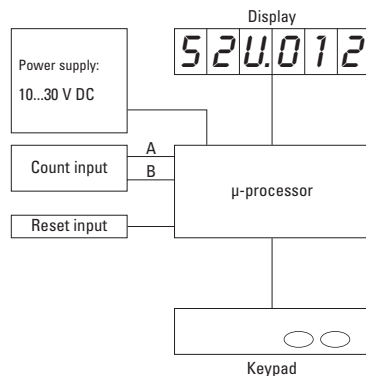

### Dimensions:

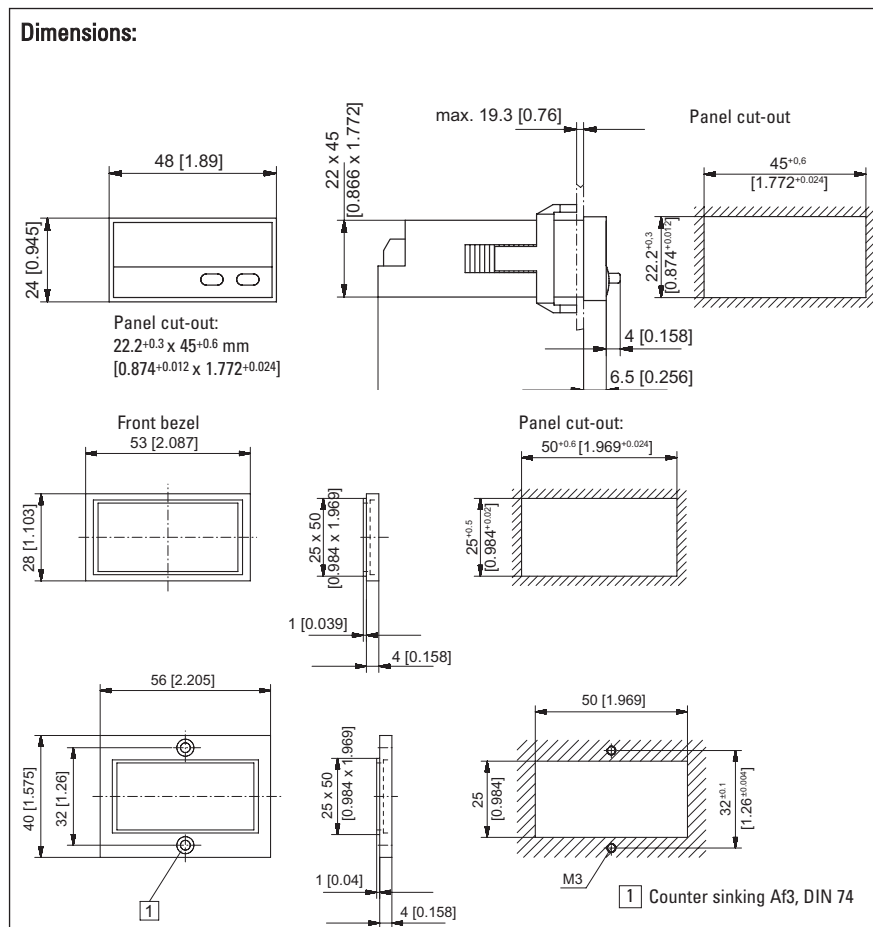

### Connections:

- without optocoupler
- |   |   |   |   |   |
|---|---|---|---|---|
| 1 | 2 | 3 | 4 | 5 |
| □ | □ | □ | □ | □ |
- 1 10 ... 30 V DC
  - 2 0 V GND
  - 3 INP A
  - 4 INP B
  - 5 Reset

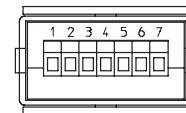

### Delivery specifications:

- 1 Digital display
- 1 Panel mounting clip
- 1 Bezel for screw mounting, panel cut out 50 x 25 mm [ 1.969 x 0.984"]
- 1 Bezel for clip mounting, panel cut out 50 x 25 mm [1.969 x 0.984"]
- 1 Seal
- 1 Multilingual operating instructions

### Order code:

6.52U.012.3X0

- Input switch level
- 0 = Standard\*
- A = 5 V

\* standard stock model

## Position and Frequency display **CODIX 52P**

separate inputs for frequency and position

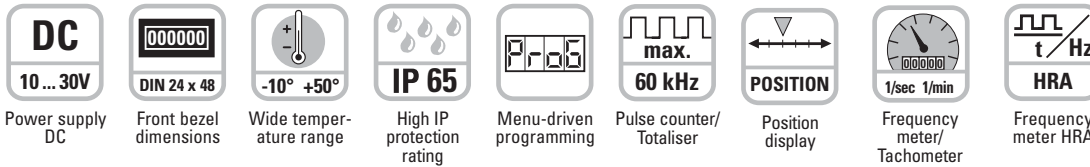

### Powerful

- **Fast count input**  
Input frequency max. 60 kHz
- **Robust housing**  
IP 65 protection
- **LED display**  
Very bright, 8 mm high
- **HRA – High Rate Accuracy System**  
Frequencies up to 38 Hz are calculated using time-interval (period duration) measurement.  
Frequencies > 38 Hz are calculated using a special time base (gate time) measurement. A very high accuracy of > 0.1% is achieved, even with very short gate times. The resulting measurement is available after a max. of 50 ms.
- **Fast start-up time**  
Detects incoming pulses just 16 ms after being switched on – so no pulses are lost with a simultaneous motor start-up



### User-friendly

- **Big keys**  
Can also be operated when using gloves
- **Easy to programme**  
Easy menu-driven programming and operation  
Possibility to enter the programming mode during operation, with authentication query  
Pressing the right key switches between displays

### Universal

- **Individually programmable scaling**  
Multiplication and division factor (0.0001 to 99.9999), to display corresponding engineering units, e.g. position in 1/10 mm and speed in RPM
- **Separate factors and inputs for frequency- and pulse counting**
- **4 different count input modes for the position display**  
2-channel input for detecting count direction, difference or adding mode, quadrature x1, x2 or x4. 1 separate input for rotary speed and speed, display in 1/min or 1/sec
- **DC supply**
- **Inputs**  
As an alternative to the HTL inputs, devices with a 5 VDC input trigger level are available, for use as parallel displays for PLCs

### Applications for Frequency and Position Display/ Totaliser

Position and rotary speed applications, e.g.

- OEM equipment or retrofitting to drilling machines
- OEM equipment on flow measuring plant, e.g. total flow and current flow

- Total piece count and pieces per minute, where the pulse counting occurs in the add/subtract mode, in order to deduct reject parts

- Production data acquisition: total piece count and production speed, or absolute distance traversed and current speed

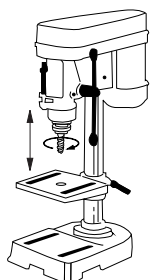

Rotary speed and drilling depth

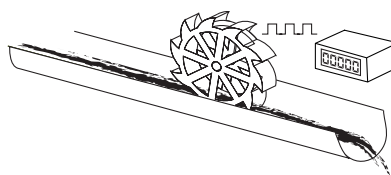

Flow rate and total volume

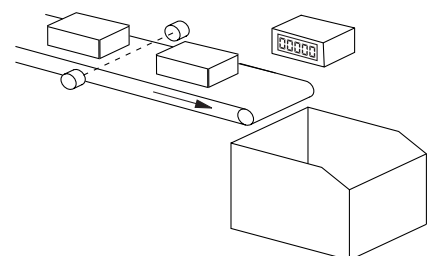

Piece count on conveyor and production speed

## Position and Frequency display **CODIX 52P**

### Technical data:

Supply voltage:	10 ... 30 V DC, with reverse polarity protection	Level of inputs:	Low: 0 ... 0.2 x U <sub>B</sub> [V DC] High: 0.6 x U <sub>B</sub> ... 30 V DC
Current consumption:	max. 40 mA	Level of inputs: 5 V version	Low: 0 ... 2 V DC High: 4 ... 30 V DC
Display:	6-digit 7-segment red LED; 8 mm [0.315"] high	Accuracy:	<0.1 % (Frequency display, tachometer)
Data backup:	EEPROM	EMC:	according to EC EMC directive 89/36/EWG
Housing:	Dimension 48 x 24 mm [1.89 x 0.945"] according to DIN 43 700; RAL 7021, grey	Emitted interference:	EN 61000-6-4/EN 55011 class B
Polarity of inputs:	programmable, npn or pnp for all inputs	Immunity to interference:	EN 61000-6-2
Input resistance:	approx. 5 kΩ	Ambient temperature:	-10 ... +50 °C [14 ... 122 °F]
Counting frequency:	30 kHz, can be damped to 30 Hz	Storage temperature:	-25 ... +70 °C [-13 ... 158 °F]
Reset time:	5 ms	Protection:	IP 65 front side
		Weight:	approx. 50 g [1.764 oz]

### Block diagram:

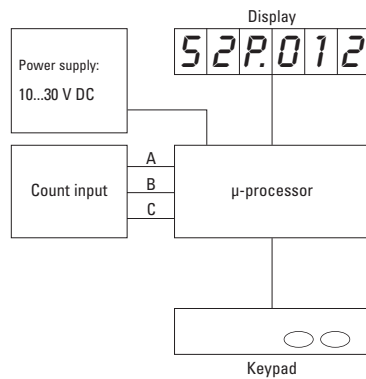

### Dimensions:

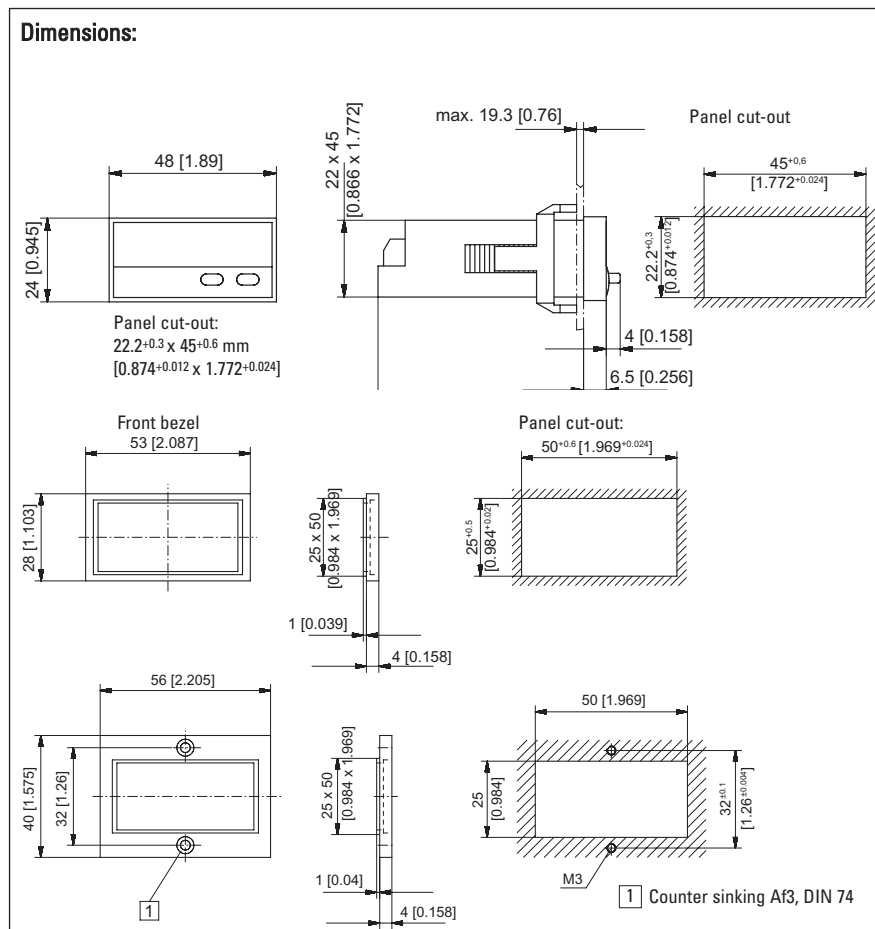

### Connections:

- without optocoupler
- |   |   |   |   |   |
|---|---|---|---|---|
| 1 | 2 | 3 | 4 | 5 |
| □ | □ | □ | □ | □ |
- 1 10 ... 30 V DC
  - 2 0 V GND
  - 3 INP A
  - 4 INP B
  - 5 Reset

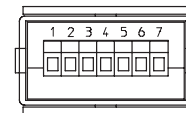

### Delivery specifications:

- 1 Digital display
- 1 Panel mounting clip
- 1 Bezel for screw mounting, panel cut out 50 x 25 mm [ 1.969 x 0.984"]
- 1 Bezel for clip mounting, panel cut out 50 x 25 mm [1.969 x 0.984"]
- 1 Seal
- 1 Multilingual operating instructions

### Order code:

6.52P.012.3X0

Input switch level  
0 = Standard\*  
A = 5 V

\* standard stock model

## Frequency meter/Tachometer CODIX 542

- Fast High Rate Accuracy System (HRA)
- Display scaleable 1/min or 1/sec

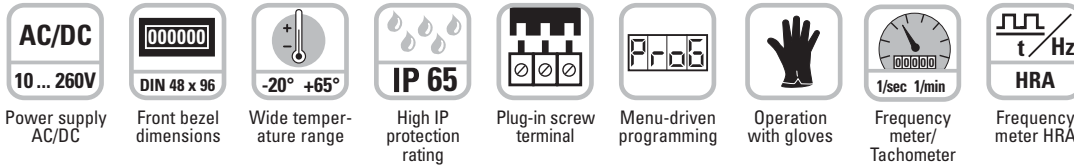

### Powerful

- **Fast count input**  
Input frequency max. 60 kHz
- **Robust housing**  
IP 65 protection
- **LED display**  
Very bright, 14 mm high
- **HRA – High Rate Accuracy System**  
Frequencies up to 38 Hz are calculated using time-interval (period duration) measurement. Frequencies > 38 Hz are calculated using a special time base (gate time) measurement. A very high accuracy of > 0.1% is achieved, even with very short gate times. The resulting measurement is available after a max. of 50 ms.
- **Fast start-up time**  
Detects incoming pulses just 16 ms after being switched on – so no pulses are lost with a simultaneous motor start-up



### User-friendly

- **Big keys**  
Can also be operated when using gloves
- **Easy to programme**  
Easy menu-driven programming and operation  
Possibility to enter the programming mode during operation, with authentication query

### Universal

- **Individually programmable scaling**  
Multiplication and division factor (0.0001 to 99.9999), to display corresponding engineering units, e.g. position in 1/10 mm and speed in RPM
- **Programmable decimal point**  
Can be set between 0.0 and 0.000 – this determines the resolution
- **Programmable delay until 0 is displayed**
- **Display in 1/min or 1/sec**
- **AC or DC power supply**
- **Inputs**  
As an alternative to the HTL inputs, devices with a 5 VDC input trigger level are available, for use as parallel displays for PLCs
- **Optional output**  
For zero-speed monitoring

### Applications for Speed and Frequency Displays

- Rotary speed applications, e.g. OEM equipment or retrofitting to drilling machines
- OEM equipment for flow rate measuring, e.g. current flow rate; production data such as volume/time
- Speed applications on motors, turbines, machines; feed-rate measurement
- Recording of production rates
- Frequency measurement

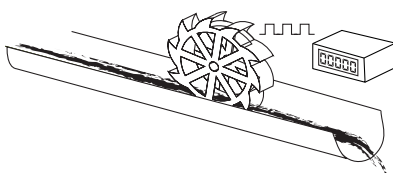

Mass flow rate

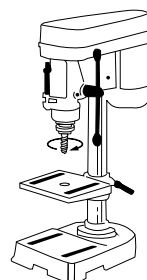

Drilling machine head, rotary speed

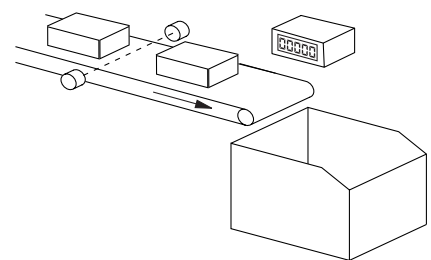

Production rate



## Frequency meter/Tachometer CODIX 542

### Technical data:

Supply voltage:	10 ... 30 V DC, with reverse polarity protection 90 ... 260 V AC
Current consumption:	max. 50 mA, 6 VA
Display:	6-digit 7-segment red LED-display; 14 mm [0.551"] high
Data retention:	EEPROM
Housing:	Dimension 96 x 48 mm [3.78 x 1.89"] according to DIN 43 700; RAL 7021, grey
Polarity of the inputs:	programmable, npn or pnp
Input resistance:	approx. 5 kΩ
Count frequency*:	max. 60 kHz, can be damped to 30 Hz depending on operating mode
Measurement principle:	Period duration measurement with averaging at higher frequencies
Input switching level (standard version):	DC version: Low: 0 ... 0,2 x U <sub>B</sub> [V DC] High: 0.6 x U <sub>B</sub> ... 30 V DC

AC version:	Low 0 ... 4 V DC High 12 ... 30 V DC
Input switching level (5 V version):	Low 0 ... 2 V DC High 4 ... 30 V DC
Voltage output for sensors:	24 V DC ±15 %/100 mA for AC-version
Accuracy:	<0.1 %
Ambient temperature:	-20 ... +65 °C [-4 ... 149 °F] non-condensing
Storage temperature:	-25 ... +70 °C [-13 ... 158 °F]
EMC:	according to EC EMC directive 89/36/EWG
Interference emissions:	EN 61000-6-4/EN 55011 class B
Interference resistance:	EN 61000-6-2
Protection:	IP 65 front side
Weight:	approx. 150 g [5.291 oz]

\*for further information please refer to the manual

### Block diagram:

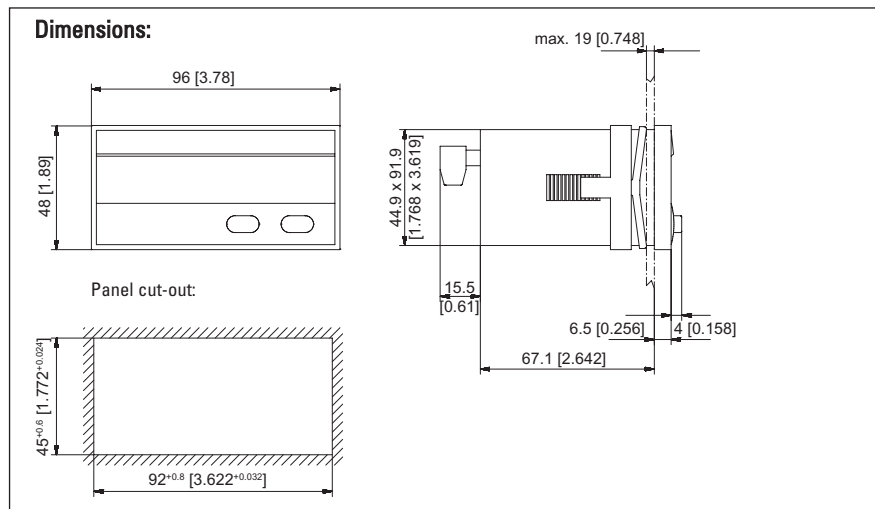
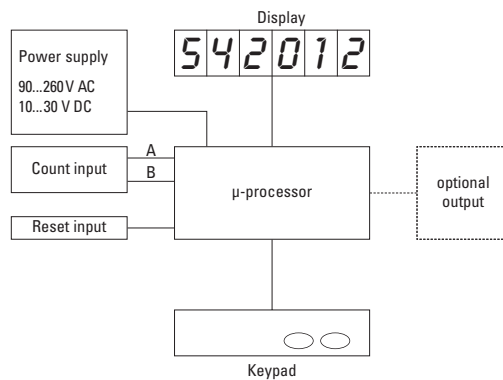

### Order code:

**6.542.01X.XX0**

Output  
1 = Optocoupler-output  
2 = No output\*

Switching level of inputs  
0 = standard\*  
A = 5 V level

Power supply  
0 = 90 ... 260 V AC\*  
3 = 10 ... 30 V DC\*

\* standard stock model

### Connections:

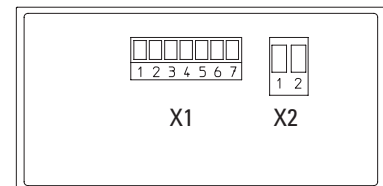

#### Connection: X2

Pin	AC-version	DC-version
1	90 ... 260 V AC	0 V DC (GND)
2	90 ... 260 V AC	10 ... 30 V DC

#### Connection: X1

Pin	AC-Version	DC-Version
1	Optocoupler-output Collector	
2	Optocoupler-output Emitter	
3	n. c.	
4	n. c.	
5	INP A	
6	GNDout	n.c.
7	+24 Vout	n.c.

**Delivery specifica-  
tion:**  
Digital display  
Mounting clip

Seal  
Multilingual operat-  
ing instructions

## Multifunction display *CODIX 544*

programmable as:

- Pulse counter
- Position display
- Frequency / speed display
- Timer/ short time meter



Power supply  
AC/DC



Front bezel  
dimensions

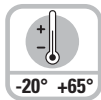

Wide temper-  
ature range



High IP  
protection  
rating



Plug-in screw  
terminal



Menu-driven  
programming

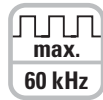

Pulse counter/  
Totaliser

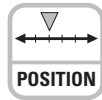

Position  
display



Frequency  
meter/  
Tachometer



Timer/  
Hour Meter



Frequency  
meter HRA

### Powerful

- **Fast count input**  
Input frequency max. 60 kHz
- **Robust housing**  
IP 65 protection
- **LED display**  
Very bright, 14 mm high
- **HRA – High Rate Accuracy System**  
Frequencies up to 38 Hz are calculated using time-interval (period duration) measurement.  
Frequencies > 38 Hz are calculated using a special time base (gate time) measurement. A very high accuracy of > 0.1% is achieved, even with very short gate times. The resulting measurement is available after a max. of 50 ms.
- **Fast start-up time**  
Detects incoming pulses just 16 ms after being switched on – so no pulses are lost with a simultaneous motor start-up



### User-friendly

- **Big keys**  
Can also be operated when using gloves
- **Easy to programme**  
Easy menu-driven programming and operation  
Possibility to enter the programming mode during operation, with authentication query

### Universal

- **Individually programmable scaling**  
Multiplication and division factor (0.0001 to 99.9999), to display corresponding engineering units, e.g. position in 1/10 mm and speed in RPM.
- **4 different count input modes**  
2-channel input for detecting count direction, difference or adding mode, quadrature x1, x2 or x4
- **Frequency measurement**  
Display in 1/min or 1/sec
- **Time counting**  
Pulse width or time interval measurement in hours, minutes or seconds, as well as real-time display
- **AC or DC power supply**  
With sensor power supply
- **Inputs**  
As an alternative to the HTL inputs, devices with a 5 VDC input trigger level are available, for use as parallel displays for PLCs
- **Optional output**  
Zero signal for position and count, zero-speed monitoring, 1 Hz clock pulse for active time measurement

### Applications for Multi-function Display

- Counting tasks such as quantity and piece counting, measuring and recording of speed and of operating and processing times
- Piece counting or tool-life measurement on die cutters, presses, extruders, wood-working machines, drilling machines,

- pick-and-place machines, guillotines, special-purpose vehicles etc.
- Positioning tasks on processing machines, such as sawing machines, milling machines, bending and folding machines, etc.

- Production data acquisition by means of piece counting (using difference or adding), or measurement of production times or production speeds.
- Totalizing flow, quantity and other scaleable media, or display of current flow rates.

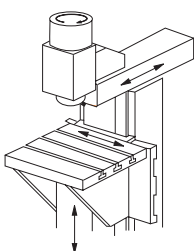

Position or rotary speed on milling machine

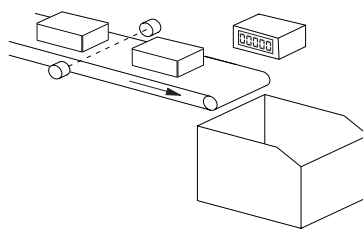

Piece count on conveyor or production speed

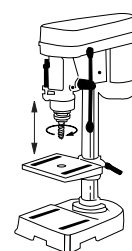

Drilling machine head, speed or drilling depth

## Multifunction display **CODIX 544**

### Technical data:

Supply voltage:	10 ... 30 V DC, with reverse polarity protection 90 ... 260 V AC
Current consumption:	max. 50 mA, 6 VA
Display:	6-digit 7-segment red LED display; 14 mm high [0.551"]
Data backup:	EEPROM
Housing:	Dimension 96 x 48 mm [3.78 x 1.89"] according to DIN 43 700; RAL 7021, grey
Polarity of Inputs:	programmable, npn or pnp for all inputs
Input resistance:	approx. 5 kΩ
Counting frequency*:	60 kHz, can be damped to 30 Hz depending on operating mode at position display max. 25 kHz
Reset time:	5 ms
Display range time	0.001 s ... 999999 h
Input switching level (standard version):	DC-version Low: 0 ... 0.2 [0 ... 0.008"] x U <sub>B</sub> [V DC] High: 0.6 x [0.024"] U <sub>B</sub> ... 30 V DC

	AC-version
	Low 0 ... 4 V DC
	High 12 ... 30 V DC
Input switching level (5 V version):	Low: 0 ... 2 V DC High: 4 ... 30 V DC
Voltage supply for sensors:	24 V DC ±15 %/100 mA at AC-versions
Accuracy:	Tachometer: <0,1 % Timer < 50 ppm
Ambient temperature:	-20 ... +65 °C [-4 ... 149 °F]
Storage temperature:	-25 ... +70 °C [-13 ... 158 °F]
EMC:	according to EC EMC directive 89/36/EWG
Emitted interference:	EN 61000-6-4/EN 55011 class B
Immunity to interference:	EN 61000-6-2
Protection:	IP 65 front side
Weight:	approx. 150 g [5.291 oz]

\*for further specifications please refer to the manual

### Block diagram:

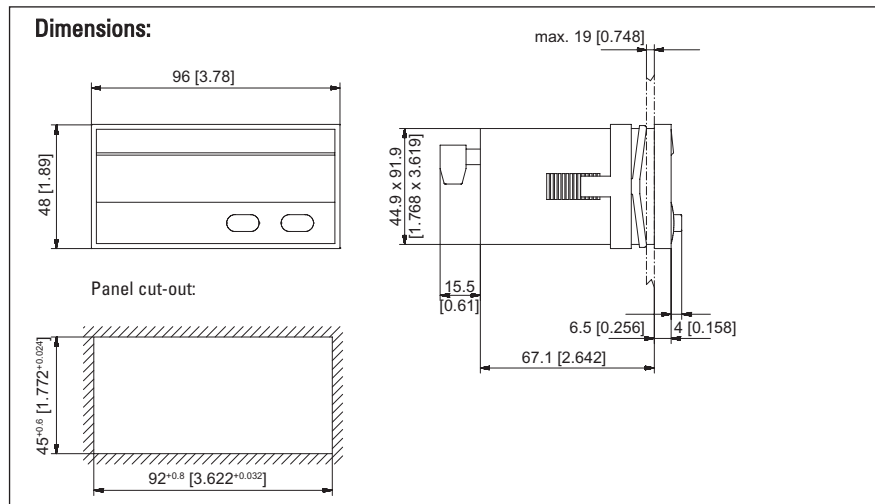
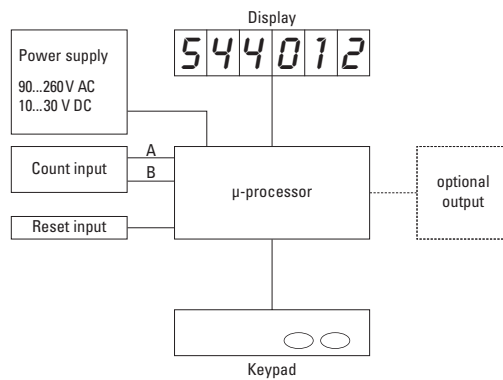

### Order code:

**6.544.01X.XX0**

Output  
1 = Optocoupler output\*  
2 = No output

Input switching level  
0 = Standard level\*  
A = 5 V level

Voltage supply  
0 = 90 ... 260 V AC\*  
3 = 10 ... 30 V DC

\* standard stock model

### Connections:

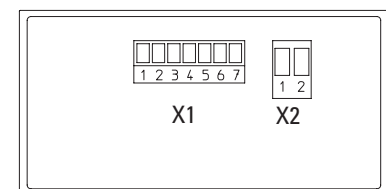

#### Connection: X2:

Pin	AC-version	DC-version
1	90 ... 260 V AC	0 V DC (GND)
2	90 ... 260 V AC	10 ... 30 V DC

#### Connection X1:

Pin	AC-version	DC-version
1	Optocoupler-output Emitter	
2	Optocoupler-output Collector	
3	Set	
4	INP B	
5	INP A	
6	GNDout	n.c.
7	+24 Vout	n.c.

**Delivery specification:** Seal  
Digital display Multilingual operating instructions  
Mounting clip

## Universal with dual functions **CODIX 54U**

**4 dual functions in one device**  
 > solves all applications where 2 different values must be displayed simultaneously.

- Counter with 2 totalizing ranges
- Totaliser and time counter
- Totaliser and frequency counter
- Timer with 2 time ranges

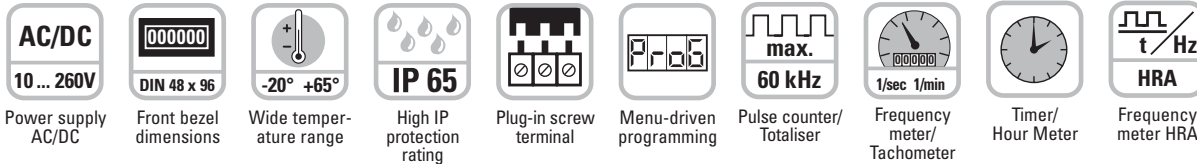

### Powerful

- **Fast count input**  
Input frequency max. 60 kHz
- **Robust housing**  
IP 65 protection
- **LED display**  
Very bright, 14 mm high
- **HRA – High Rate Accuracy System**  
Frequencies up to 38 Hz are calculated using time-interval (period duration) measurement.  
Frequencies > 38 Hz are calculated using a special time base (gate time) measurement. A very high accuracy of > 0.1% is achieved, even with very short gate times. The resulting measurement is available after a max. of 50 ms.
- **Fast start-up time**  
Detects incoming pulses just 16 ms after being switched on – so no pulses are lost with a simultaneous motor start-up



### User-friendly

- **Big keys**  
Can also be operated when using gloves
- **Easy to programme**  
Easy menu-driven programming and operation  
Possibility to enter the programming mode during operation, with authentication query  
Pressing the right key switches between displays

### Universal

- **Individually programmable scaling**  
Multiplication and division factor (0.0001 to 99.9999), to display corresponding engineering units, e.g. position in 1/10 mm and speed in RPM
- **Separate factors for frequency- and pulse counting**
- **AC or DC power supply**  
With sensor power supply
- **Inputs**  
As an alternative to the HTL inputs, devices with a 5 VDC input trigger level are available, for use as parallel displays for PLCs
- **Timer specials**  
Timer or hours-run meter with various Start Stop measurements, time range settings in hours, minutes or seconds, with decimal point. Resolutions up to 1/1000 can be programmed

### Applications for dual functions

- **Pulse and frequency (speed)**  
e.g. production data acquisition: total piece count and speed on OEM equipment, flow rate measuring systems – total flow and current flow
- **2 pulse counters**  
Measurement of batch and total piece count, or of daily production count and total count values

- **Pulse and time (Maintenance counter)**  
Used in the lift industry as trip counters and hours-run meters and on production machines for piece and time counting, flow and time measurement, materials handling time and quantities

- **2 timers**  
Measurement of total time and order-specific times, maintenance intervals and total time, time of day and total time

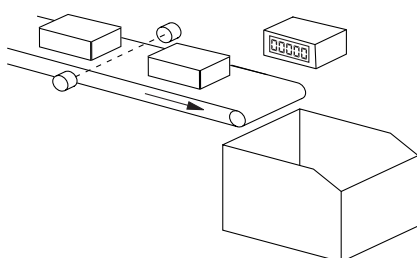

Piece count on conveyor and production speed

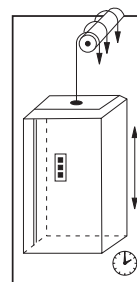

Trip counter and hours-run

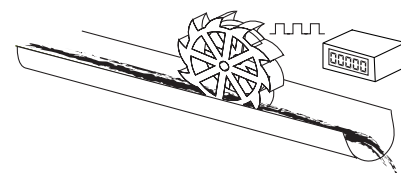

Flow rate and total volume

## Universal with dual functions **CODIX 54U**

### Technical data:

Supply voltage:	10 ... 30 V DC, with reverse polarity protection 90 ... 260 V AC
Current consumption:	max. 50 mA, 6 VA
Display:	6-digit 7-segment red LED display; 14 mm [0.551"] high
Data backup:	EEPROM
Housing:	Dimension 96 x 48 mm [3.78 x 1.89"] according to DIN 43 700; RAL 7021, grey
Polarity of Inputs:	programmable, npn or pnp for all inputs
Input resistance:	approx. 5 kΩ
Counting frequency*:	60 kHz, can be damped to 30 Hz depending on operating mode
Display range:	0.001 s ... 999999 h
Reset time:	5 ms
Input switching level (standard version):	DC-version: Low: 0 ... 0.2 [0 ... 0.008"] x U <sub>B</sub> [V DC] High: 0.6 [0.024"] x U <sub>B</sub> ... 30 V DC

	AC-version: Low 0 ... 4 V DC High 12 ... 30 V DC
Input switching level (5 V version):	Low 0 ... 2 V DC High 4 ... 30 V DC
Voltage supply for sensors:	24 V DC ±15 %/100 mA at AC version
Accuracy:	<0.1 % (Frequency display/Rate meter) <50 ppm (Timer)
Ambient temperature:	-20 ... +65 °C [-4 ... 149 °F] non-condensing
Storage temperature:	-25 ... +70 °C [-13 ... 158 °F]
EMC:	according to EC EMC directive 89/36/EWG
Emitted interference:	EN 61000-6-4/EN 55011 class B
Immunity to interference:	EN 61000-6-2
Protection:	IP65 from front
Weight:	approx. 150 g [5.291 oz]

\*for further specifications please refer to the manual

### Block diagram:

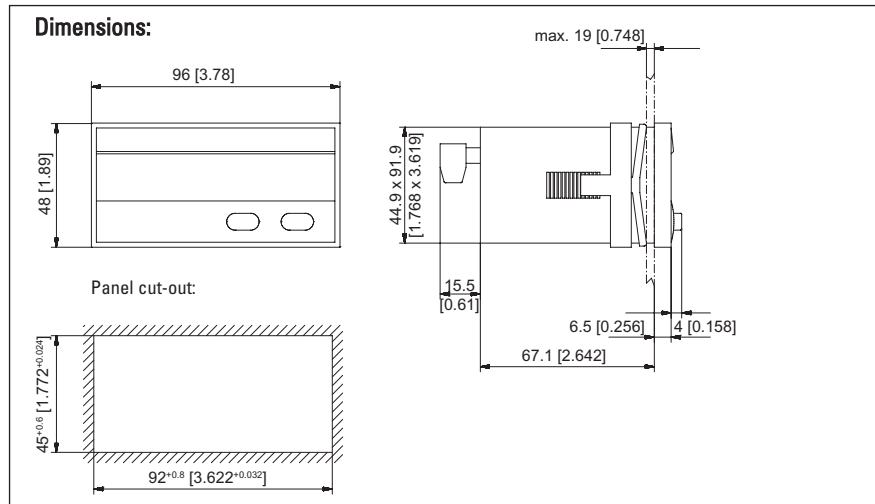
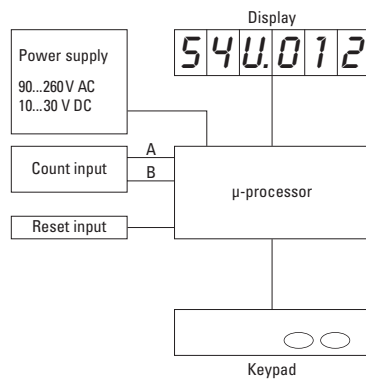

### Order code:

6.54U.012.XX0

Input switching level  
0 = Standard\*  
A = 5 V level

Power supply  
0 = 90 ... 260 V AC\*  
3 = 10 ... 30 V DC  
\* standard stock model

### Connections:

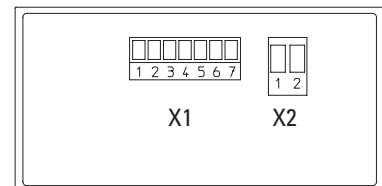

#### Connection: X2

Pin	AC-version	DC-version
1	90 ... 260 V AC	0 V DC (GND)
2	90 ... 260 V AC	10 ... 30 V DC

#### Connection: X1

Pin	AC-Version	DC-Version
1	n.c.	
2	n.c.	
3	Reset	
4	INP B	
5	INP A	
6	GNDout	n.c.
7	+24 Vout	n.c.

**Delivery specification:**  
Digital display  
Mounting clip

Seal  
Multilingual operating instructions

## Position and Frequency display **CODIX 54P**

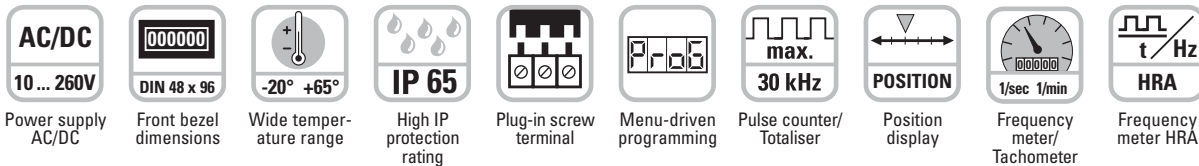

### Powerful

- **Fast count input**  
Input frequency max. 60 kHz
- **Robust housing**  
IP 65 protection
- **LED display**  
Very bright, 14 mm high
- **HRA – High Rate Accuracy System**  
Frequencies up to 38 Hz are calculated using time-interval (period duration) measurement.  
Frequencies > 38 Hz are calculated using a special time base (gate time) measurement. A very high accuracy of > 0.1% is achieved, even with very short gate times. The resulting measurement is available after a max. of 50 ms.
- **Fast start-up time**  
Detects incoming pulses just 16 ms after being switched on – so no pulses are lost with a simultaneous motor start-up



### User-friendly

- **Big keys**  
Can also be operated when using gloves
- **Easy to programme**  
Easy menu-driven programming and operation  
Possibility to enter the programming mode during operation, with authentication query  
Pressing the right key switches between displays

### Universal

- **Individually programmable scaling**  
Multiplication and division factor (0.0001 to 99.9999), to display corresponding engineering units, e.g. position in 1/10 mm and speed in RPM.
- **Separate factors and inputs for frequency- and pulse counting**
- **4 different count input modes for the position display**  
2-channel input for detecting count direction, difference or adding mode, quadrature x1, x2 or x4. 1 separate input for rotary speed and speed, display in 1/min or 1/sec
- **AC or DC supply**
- **Inputs**  
As an alternative to the HTL inputs, devices with a 5 V DC input trigger level are available, for use as parallel displays for PLCs

### Applications for Frequency and Position Display/ Totaliser

Position and rotary speed applications, e.g.

- OEM equipment or retrofitting to drilling machines
- OEM equipment on flow measuring plant, e.g. total flow and current flow
- Total piece count and pieces per minute, where the pulse counting occurs in the add/subtract mode, in order to deduct reject parts
- Production data acquisition: total piece count and production speed, or absolute distance traversed and current speed

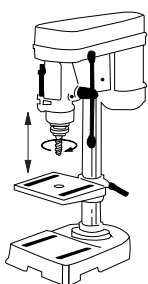

Rotary speed and drilling depth

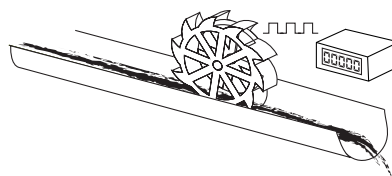

Flow rate and total volume

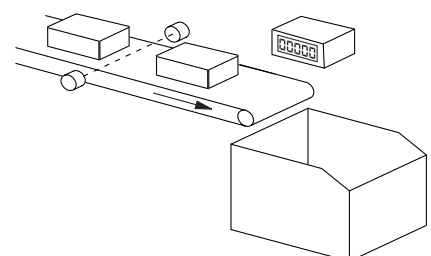

Piece count on conveyor and production speed

## Position and Frequency display **CODIX 54P**

### Technical data:

Supply voltage:	10 ... 30 V DC, with reverse polarity protection 90 ... 260 V AC
Current consumption:	max. 50 mA, 6 VA
Display:	6-digit 7-segment red LED display; 14 mm [0.551"] high
Data backup:	EEPROM
Housing:	Dimension 96 x 48 mm [3.78 x 1.89"] according to DIN 43 700; RAL 7021, grey
Polarity of Inputs:	programmable, npn or pnp for all inputs
Input resistance:	approx. 5 k $\Omega$
Counting frequency*:	30 kHz, can be damped to 30 Hz depending on operating mode
Reset time:	5 ms
Input switching level (standard version):	DC-version: Low: 0 ... 0.2 [0 ... 0.008"] x U <sub>B</sub> [V DC] High: 0.6 [0.024"] x U <sub>B</sub> ... 30 V DC

AC-version:	Low 0 ... 4 V DC High 12 ... 30 V DC
Input switching level (5 V version):	Low 0 ... 2 V DC High 4 ... 30 V DC
Accuracy:	<0.1 % (Frequency display/Rate meter)
Voltage supply for sensors:	24 V DC $\pm$ 15 %/100 mA at AC version
Ambient temperature:	-20 ... +65 °C [-4 ... 149 °F] non-condensing
Storage temperature:	-25 ... +70 °C [-13 ... 158 °F]
EMC:	according to EC EMC directive 89/36/EWG
Emitted interference:	EN 61000-6-4/EN 55011 class B
Immunity to interference:	EN 61000-6-2
Protection:	IP65 from front
Weight:	approx. 150 g [5.291 oz]

### Block diagram:

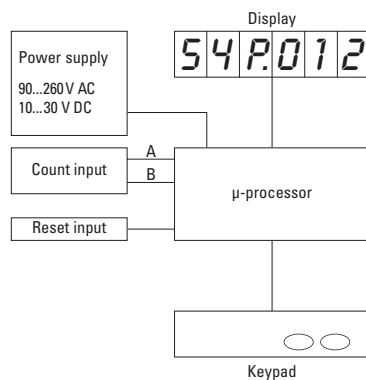

\*for further specifications please refer to the manual

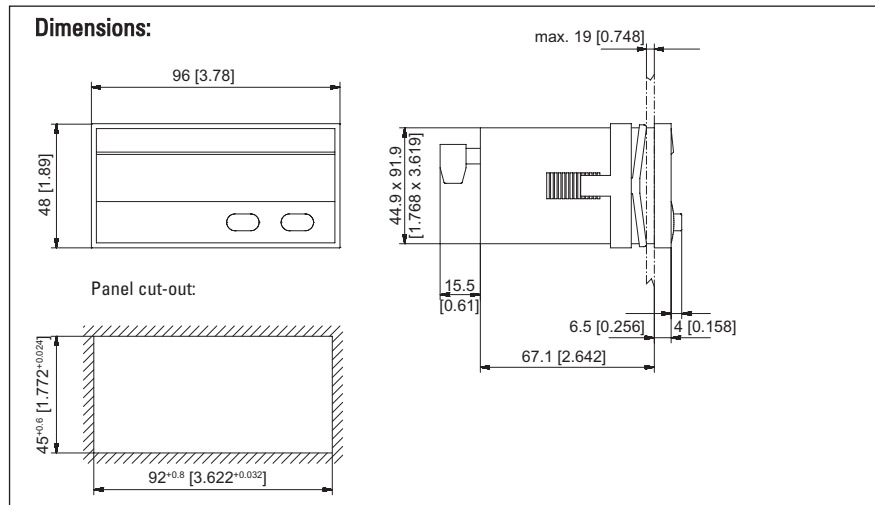

### Order code:

**6.54P.012.XX0**

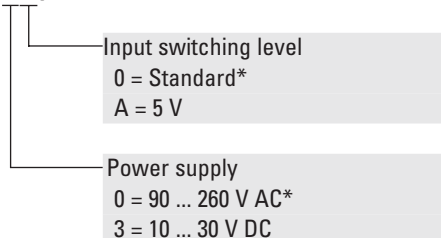

\* standard stock model

### Connections:

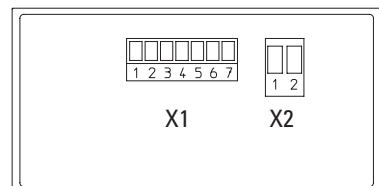

#### Connection: X2

Pin	AC-version	DC-version
1	90 ... 260 V AC	0 V DC (GND)
2	90 ... 260 V AC	10 ... 30 V DC

#### Connection: X1

Pin	AC-Version	DC-Version
1	n.c.	
2	n.c.	
3	INP C (Frequency)	
4	INP B (Count)	
5	INP A (Count)	
6	GNDout	n.c.
7	+24 Vout	n.c.

### Delivery specification:

Digital display  
Mounting clip  
Seal  
Multilingual operating instructions

## Universal Preset Counter *CODIX* 923 / 924

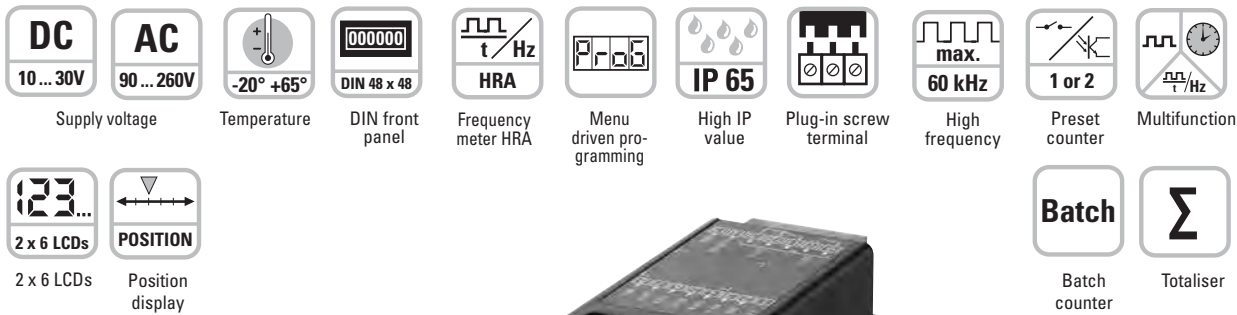

Made in Germany by Kübler

### Multifunction:

- Counter, Tachometer and Timer – all in one device
- Can be used as preset counter, batch counter or totaliser (overall cumulative count)
- 1 or 2 presets (additional presets on request)
- Relay or optocoupler outputs
- Wide choice of count modes for pulse inputs, time or frequency
- Averaging, start delay (Tachometer)
- Scalable display with multiplikation and division factor, set value
- Step or tracking presets

### Fast:

- Direct input of the presets via the front keys or the Teach-In input
- Fast installation thanks to plug-in screw terminals and integrated sealing gaskets
- Max. count frequency 60 kHz

### User-friendly:

- Simultaneous display of the actual value, presets, batch count or total count
- Annunciators for the displayed preset and for the output status
- 3 predefined settings for the most common parameter settings
- Direct entry into the programming
- Tracking presets eliminate the need for reprogramming of the pre-signal
- Minimum installation depth
- 4 stage RESET modes
- 3 stage key lockout

### Technical data:

Supply voltage:	90 ... 260 V AC/max. 8 VA, 50/60 HZ, External fuse protection T 0.1 A 10 ... 30 V DC/max. 1.5 W External fuse protection T 0.2 A	
Display:	2-line 6-digits LCD display LCD pos. (green) backlighting	
Count inputs:	Polarity of the inputs: programmable for all inputs in common NPN/PNP Input resistance: 5 k $\Omega$ Count frequency: max. 55 kHz (details see manual) Min pulse duration of the inputs: 10 ms / 1 ms	
Switching levels with AC-supply:	HTL-level: Low: 0 ... 4 V DC High: 12 ... 30 V DC 5 V-level: Low: 0 ... 2 V DC High: 3.5 ... 30 V DC	
Switching level with DC-supply:	HTL-level: Low: 0 ... 0.2 x U <sub>B</sub> High: 0.6 x U <sub>B</sub> ... 30 V DC 5 V-level: Low: 0 ... 2 V DC High: 3.5 ... 30 V DC	
Pulse shape:	variable, Schmitt-Trigger characteristics	
Output	Switching voltage	max. 250 V AC/110 V DC
	Switching current	max. 3 A AC/A DC

Output 1	Switching current	min. 30 mA DC
	Switching capacity	max. 750 VA/90 W
	Mech. service life (switching cycles)	2 x 10 <sup>7</sup>
	N° of switching cycles at 3 A/250 V AC	1 x 10 <sup>5</sup>
	N° of switching cycles at 3 A/30 V DC	1 x 10 <sup>5</sup>
	Relay closing contact, programmable as normally open (NO) or normally closed (NC)	
Output 2	Mech. service life (switching cycles)	20 x 10 <sup>6</sup>
	N° of switching cycles at 3 A/250 V AC	5 x 10 <sup>4</sup>
	N° of switching cycles at 3 A/30 V DC	5 x 10 <sup>4</sup>
	Relay with changeover contact	
or npn optocoupler:	switching power	30 V DC/10 mA
	U <sub>CESAT</sub> at IC = 10 mA:	max. 2.0 V
	U <sub>CESAT</sub> at IC = 5 mA:	max. 0.4 V
Reaction time of the outputs:	Relay:	approx 7 ms
	Optocoupler:	approx 1 ms, Details see instruction manual
Response time of the frequency counter:	100/600 ms, Details see instruction manual	
Data retention:	min. 10 years, EEPROM	
Count modes:		
Pulse counter:	cnt.dir, up.dn, up.up, quad, quad 2, quad4, A/B, (A-B)/A x 100%	
Frequency counter:	A, A-B, A+B, quad, A/B, (A-B)/A x 100%	
Timer:	FrErun, Auto, InpA.InpB., InpB.InpB.	



# Tachometer /Frequency meter with limits



## Technical Data:

Voltage supply for sensors:	
AC supply	24 V DC ± 15%, 80 mA
DC supply	max. 80 mA, external voltage supply is connected through
Operating temperature:	-20 °C ... +65 °C
Storage temperature:	-25 °C ... +75 °C

Humidity:	RH 93% at +40 °C, non-condensing
EMC:	CE compliant to EU directive 89/36/EWG
Standards:	EN 61 000-6-4/EN 55011 class B EN 61000-6-2
UL (applied for):	File-N°.: E128604
Protection:	IP65 (front)
Weight:	approx. 125 g

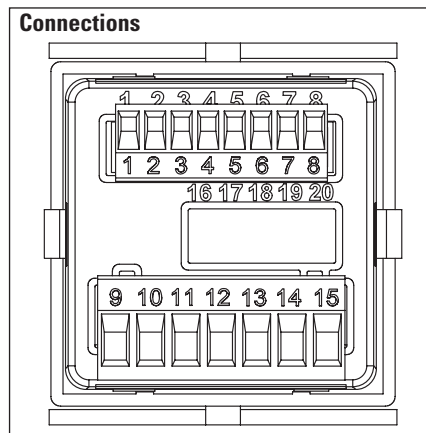
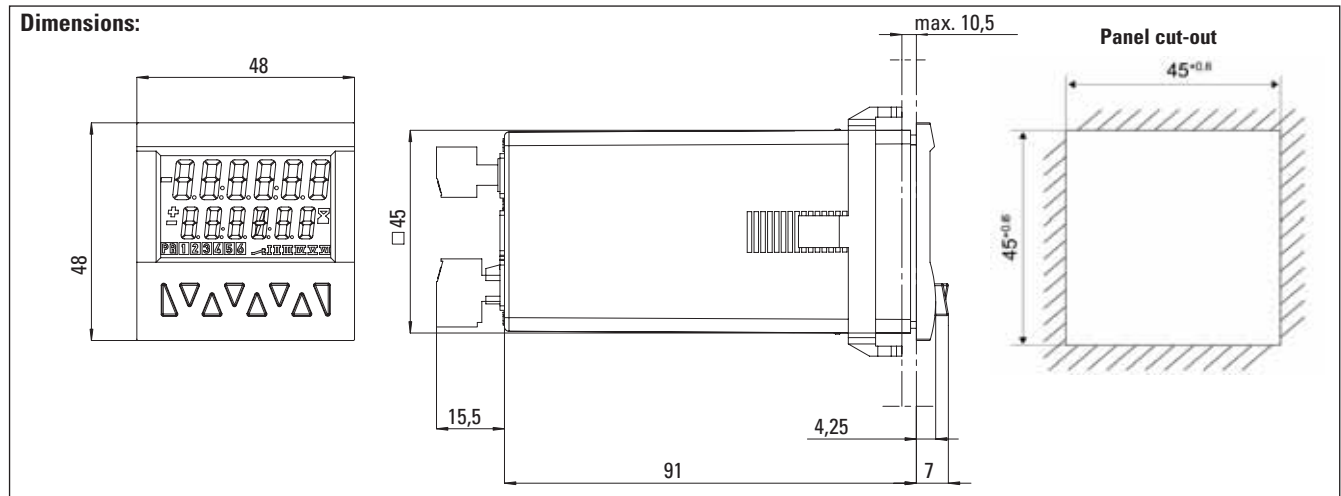

### Signal and control inputs

- 1 Sensor voltage supply  
AC: 24 VDC/80 mA  
DC: UB interconnected
- 2 GND (0 VDC)
- 3 INP A (Signal input A)
- 4 INP B (Signal input B)
- 5 RESET (Reset input)
- 6 LOCK (Key locking input)
- 7 GATE (Gate input)
- 8 MPI (User input)
- 16 ... 20:  
Additional optional inputs or outputs or interfaces

### Version with relays/optocouplers

- |                                    |                  |
|------------------------------------|------------------|
| 9 Relay contact C./Collector       | } Output 1       |
| 10 Relay contact N.O./Emitter      |                  |
| 11 Relay contact C./Emitter        | } Output 2       |
| 12 Relay contact N.O./not assigned |                  |
| 13 Relay contact N.C./ Collector   | } Supply voltage |
| 14 AC: 90..260 VAC N~              |                  |
| DC: 10..30 VDC                     |                  |
| 15 AC: 90..260 VAC L~              |                  |
| DC: GND (0 VDC)                    |                  |

### Delivery specification:

- Preset counter
- Mounting clip
- Operating instructions

## 6.92X.01XX.XX0

### Order code:

Number of presets  
3 = 1 preset  
4 = 2 preset

Outputs  
0 = Relays  
1 = Optocouplers (only 924)

LCD options  
0 = no backlighting  
1 = green backlighting

Input trigger level  
0 = Standard level (HTL)  
A = 5 V-level

Supply voltage  
0 = 90–260 V/AC  
3 = 10–30 V/DC

Options: Additional inputs or outputs or interfaces on request

### Standard stock models:

6.923.0100.000 6.924.0100.000  
6.923.0100.300 6.924.0100.300

## Areas of application for 923/924:

### ■ Pulse counter

#### Functions/ Count modes

- Count with direction mode
- Difference mode
- Quadrature mode quad/quad2/quad4
- Add, Sub, automatic reset
- 2-input adding mode A+B
- Ratio measurement A/B
- Percentage difference measurement  $(A-B)/A \times 100\%$
- Batch counting
- Totaliser (Overall total)
- Multiplication and division factor (up to 99.999)
- Set value
- Step or tracking preset

#### Application examples

##### CountDir

Roller shutter door with automatic shutoff

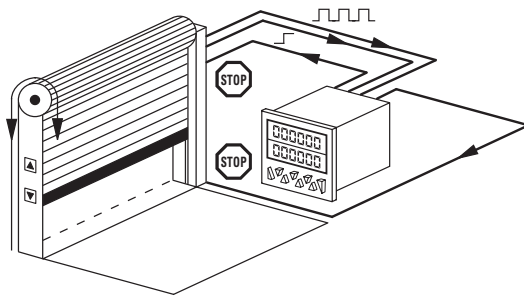

##### Quad

Running direction and position on milling machines

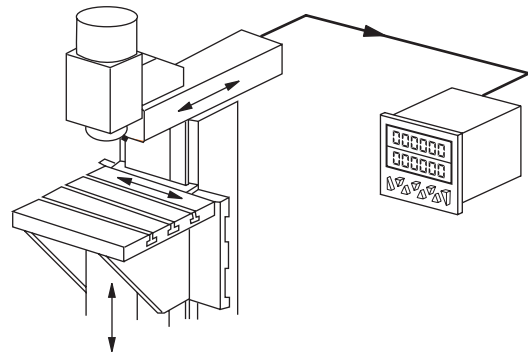

##### UpDown

Automatic subtraction of faulty or reject parts from the total piece count

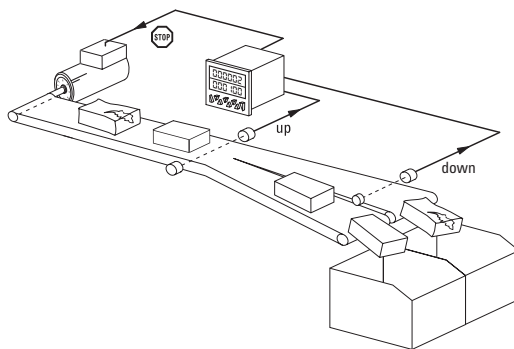

##### Batch

Logging of piece numbers and packing units plus control of replenishment of packing cartons

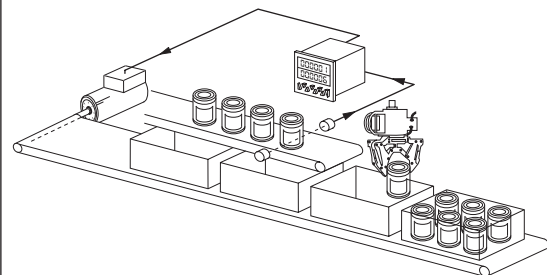

##### UpUp

Adding up of two parallel or staggered production lines

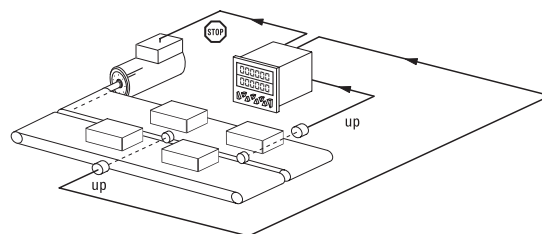

##### Add tot

Cut-to-length with overall total count

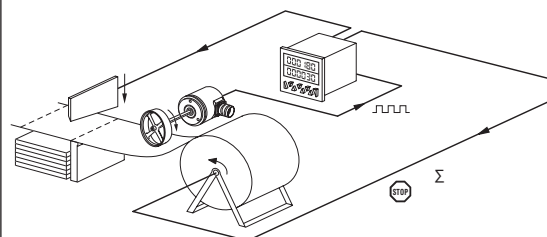

## Areas of application for 923/924:

### ■ Frequency counter (Tachometer)

#### Functions/ Count modes

- A
- B
- A – B
- A + B
- A / B
- (A – B) / A x 100 % (percentage display)
- Quad (Phase discriminator with recognition of direction)
- Averaging
- Start delay
- 2nd tacho input
- Gate input
- Multiplication and division factor (up to 99.9999)

<b>Application examples</b>	<b>A – B</b> Synchro monitoring and control of two conveyor belts 	<b>Speed regulation with indication of direction</b> 
	<b>Ratio measurement A/B</b> 	<b>Ratio measurement e.g. for speed alignment</b> 

### ■ Time and hours-run meter (Timer)

#### Functions/ Count modes

- FrErUn (Control via gate input)
- Auto (Start via Reset, Stop at preset)
- InpB.InpB (Start with first edge at InpB., Stop with second edge InpB.)
- InpA. InpB (Start with InpA., Stop with InpB.)
- Totaliser (Overall total)
- Batch counting
- Set value
- Step or tracking preset

<b>Application examples</b>	<b>Interval measurement InpB. InpB</b> 	<b>FrErUn</b> Measurement of overall time from switching on the conveyor belt till switching off 
	<b>Run-time measurement InpA. InpB.</b> 	<b>Auto</b> time-controlled production line 

## Universal Preset Counter **CODIX 923 /924**

Your control solution, ready-to-go · very easy to operate · direct display · expandable via module individual functionality.



### Multifunction

More than just preset counters: the **CODIX 923/924** are multi-talented and can handle the display, measurement and control of pulses (counter), frequencies (tacho) and time (timer) using numerous count functions and modes.

**Open to many applications.** The great advantage of the **CODIX 923/924** preset counters: they offer a simple and cost-effective solution for many local standard control functions. It is not necessary to have in-depth programming knowledge when installing or using the product, which does away with the need for costly service engineers.

### Expandable

Numerous logic functions and preconfigured, selectable operating modes for a variety of applications, including for example positioning and batch counting, make the counter a real alternative to a PLC – and with the benefit of a display included.

The devices are so designed that they are expandable for OEM applications. Both hardware and software can be modified and expanded. PCB-board receptacles are provided in the counter for hardware upgrade purposes:

- Up to 10 inputs
- Up to 6 optocoupler outputs
- Up to 4 relay outputs
- Interface RS 232/485
- Individual functions

The software can be specifically customised to OEM applications. This includes the logic behaviour of the inputs and outputs (I/O functionality) or the whole display unit.

Expandable on request via modules:

- 4 additional inputs
- or 4 additional optocoupler outputs
- or 2 additional relay outputs
- or RS 232/485 interfaces

Application examples:

- Limit switch monitoring
- Special functions/PLC function
- Initiation of fixed program sequences
- Control of several processes
- Special protocols
- Print commands for logging

Individual customisation of software to your application.

For example:

- Separate inputs for total counter and preset counter
- Separate scaling of input A and B
- Programmable measuring period for the tachometer
- Measurement of rotary speeds based on time
- Processing time, measurement of time based on frequency

Expandable hardware:



Customisable software:



With your logo:



Free-off-charge for 100+ pcs.

Typically a simple OEM customisation is worthwhile for annual quantities of 20-50 pcs. We would be happy to solve this task for you quickly, professionally and economically.  
Phone +49 (0) 77 20 - 39 03-38  
or info@kuebler.com

## Universal Preset Counter **CODIX 923 / 924**

### User-friendly



*Fresh, modern design that further enhances your panel or equipment.*

**Simple filing-cabinet programming structure** for fast entry of parameters. Quickly operational: after each parameter has been modified, it is possible to exit the programming by means of the reset key.

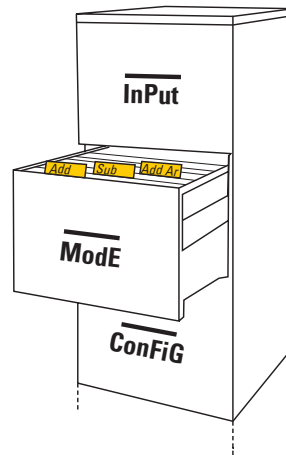

**Convenient time-saving installation:** Plug-in screw terminal connections with cage clamp terminals. IP 65 sealed front bezel as standard. Saves additional time & effort for protection when installing. Minimal installation depth – will fit anywhere

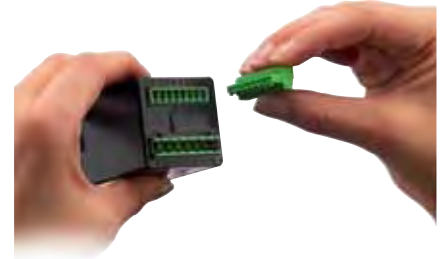

**Comprehensive, large display:** 2-line, 2 x 6-digit LCD display with sign, leading zero suppression, giving a display range from -999 999 to +999 999. Optional backlighting for good readability in all situations.

**Easy-to-operate** without programming knowledge. Direct access to the programming mode for all count functions. User-friendly, thanks to the simplified programming structure and alpha-numeric display of the parameters.



**Easy-to-understand:** thanks to the use of annunciators for the displayed preset and the status of both outputs, as well as the simultaneous display of the actual value and the presets or the auxiliary counters.



**New: MPI input** (multiple purpose input) with the functions: Display Hold, Set and Teach-In.

**Three predefined settings:** with parameter settings for the most common applications.



**The compact decade key-pad:** allows for a large display and enables simple direct entry of the presets.



**Preset via Teach-In input:** for simple error-free entry of the preset. A reset key plus programming mode key are already integrated.

## Type 903/904



### Your benefit

- 2 line LCD display
- Programmable as impulse counter, frequency meter or time meter with sign and zero blanking
- Power supply  
90 ... 260 V AC or 10 ... 30 V DC
- approval
- Batch mode

### Further product features

- Display range -199 999 ... 999 999 with zero blanking
  - Easy to operate and set the preset values via 4 keys
  - Relay or optocoupler-output
  - Scaling factor 0.0001 ... 9.9999
- 903:** 1 preset value, 1 output  
**904:** 2 preset values, 2 outputs

### Technical data:

Supply voltage:	10 ... 30 V DC, max. 1,1 W with reverse polarity protection. 90 ... 260 V AC max. 4 VA	or npn optocoupler:	with open collector and emitter switching power 30 V DC/15 mA
Display:	2 line LCD display, 6-digits	Output 2     Relay:	with potential free contact, programmable as normally open or normally closed. switching voltage max. 250 V AC/125 V DC, switching current max. 3 A switching current at DC min. 30 mA switching power at DC 90 W at AC max. 750 VA
Count inputs:	2 count inputs, 4 input modes are programmable	or npn optocoupler:	with open collector and emitter switching power 30 V DC/15 mA
Polarity of the inputs:	programmable for all inputs in common	Reaction time of the outputs:	relay: approx. 7 ms optocoupler: approx. 1 ms
Input resistance:	approx. 10 kΩ	Data retention:	min. 10 years or 1x10 <sup>6</sup> memory cycles
Count frequency:	via DIL switches for INP A and INP B can be set separately 30 kHz 10 kHz for input modes E3 and E4 (quadrature) for automatic repeat - 900 Hz without losing counts (500 Hz for input mode E4)	Transmitter voltage:	24 V DC -40 %/+15 %, 100 mA at 90 .. 260 V AC with optional backlighting: 24 V DC -40 %/+15 %, 60mA at 90 ... 260 V AC
Min. pulse duration of the inputs:	5 ms	Ambient temperature:	0... +50 °C [32 ...122 °F]
Input sensitivity:	DC supply voltages: Low: 0 ... 0.2 x U <sub>B</sub> [V DC] High: 0.6 x U <sub>B</sub> ... 30 [V DC] AC supply voltages: Low 0 ... 4 V DC High 12 ... 30 V DC	Storage temperature:	-25 ... +70 °C [-13 ... 158 °F]
Pulse shape:	variable (Schmitt-Trigger characteristics)	EMC:	according to EC EMC directive 89/36/EWG
Output 1     Relay:	with potential free contact, programmable as normally opened or normally closed. switching voltage max. 250 V AC/125 V DC, switching current max. 3 A. switching current at DC min. 30 mA switching power at DC 90 W at AC max. 750 VA	Emitted interference:	EN 61 000-6-4/EN 55011 class B
		Immunity to interference:	EN 61 000-6-2
		UL:	File E128604
		Protection:	IP 65 front side EX version IP 54
		Weight:	approx. 240 g [8.466 oz], AC version with relay

### Inputs:

#### INP A, INP B

Count inputs: the max. count frequency of 10kHz can be damped for each channel to 30 Hz.

#### Gate

Static gate input; no counting while this input is activated

### Reset

Dynamic reset input; it is connected in parallel to the red reset key and sets the counter to zero (adding mode) or to the preset value (subtracting mode)

### Key

Static keyboard lock input; while this input is activated, the front keys are locked for operations

### Outputs:

2 potential free outputs (903: 1 output), versions with relay or optocoupler available

### Programming:

The types 903 and 904 are programmed via only 4 keys on the front side. Trouble-free and intuitive operation through clear text user guidance on the display. The operating parameters are chosen from a menu. The device can be used as:

1. Pulse counter
2. Frequency meter
3. Time meter

Therefore the following functions are programmable:

### Polarity of the inputs:

Positive (pnp) or negative (nnp) polarity of the inputs. The selected polarity applies to all inputs.

### Operating modes, impulse counter and timer:

- adding, starting at zero
- subtracting, starting at the preset value (903) or at preset value 2 (904)
- adding with automatic reset to zero at preset value (903) or preset value 2 (904)
- subtracting with automatic reset to preset value (903) or preset value (904) at zero.

### Input modes, impulse counter and frequency meter:

- E1 1 count input, 1 count direction input
- E2 1 Count input up  
1 Count input down
- E3 Quadrature input  
to connect encoders with 2 signals shifted by 90°

- E4 Quadrature input with pulse doubling  
to connect encoders with 2 signals shifted by 90°

### Decimal places:

The display is possible with two or three decimal places

### Scaling factor:

For optimizing the operation with an encoder a scaling factor of 0.0001 ... 9.9999 may be programmed

### Output signal:

Selectable as NO contact or NC contact, positive or negative timed signal (duration 0.01 ... 99.99 s)

### Gate time for frequency meter:

Selectable from 0.01 ... 99.99 s

### Hour meter:

Timing in h, min or s, with a resolution of 0.001, 0.01, 0.1 or h:min:s

### Applications:

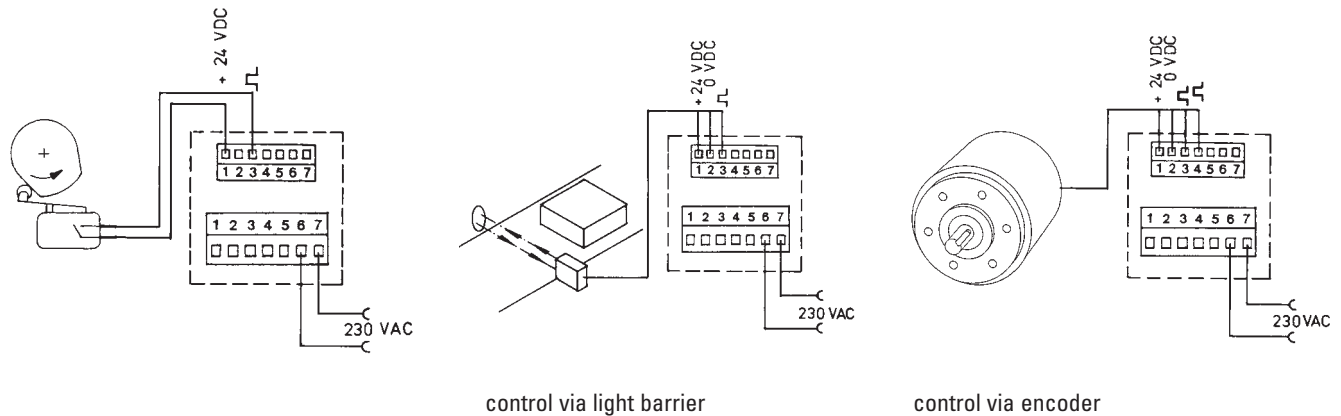

### Connection diagram 904:

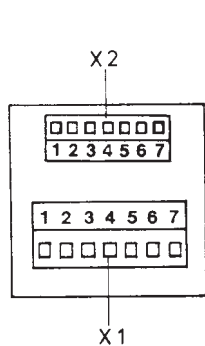

#### Pin connection X1:

Pin	AC version	DC version
1	Output 1 Relay collector at optocoupler output	
2	Output 1 Relay emitter at optocoupler output	
3	Output 2 Relay common contact (c) emitter at optocoupler output	
4	Output 2 Relay normally open (NO)	
5	Output 2 Relay normally closed (NC) collector at optocoupler output	
6	Supply voltage	
7	90 ... 260 V AC	11 ... 30 V DC
	90 ... 260 V AC	0 V DC (GND)

#### Pin connection X2:

Pin	Description	AC version	DC version
1	+24 V DC	Transmitter voltage supply	n.c.
2	0 V DC (GND)	GND	n.c.
3	INP A	Count input A	
4	INP B	Count input B	
5	Reset	Reset input	
6	Gate	Gate input	
7	Key	Key locking input	

**Dimensions:**

903/904

Panel cut-out 45 x 45 mm [1.772 x 1.772"]

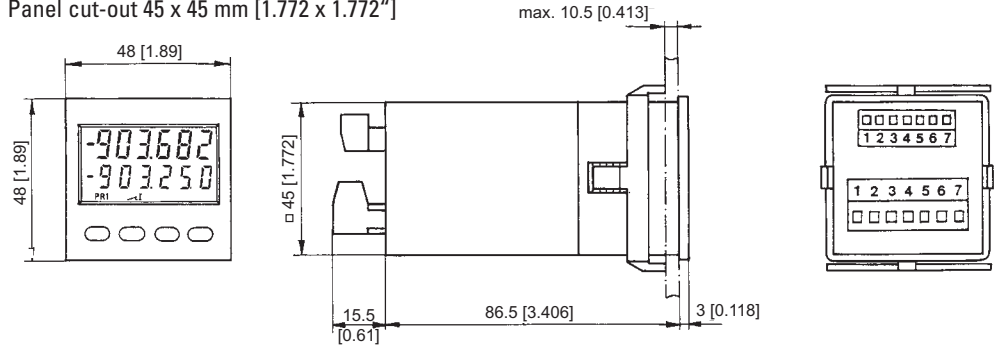

903/904 with front bezel no 2

Panel cut-out 50 x 50 mm [1.969 x 1.969"]

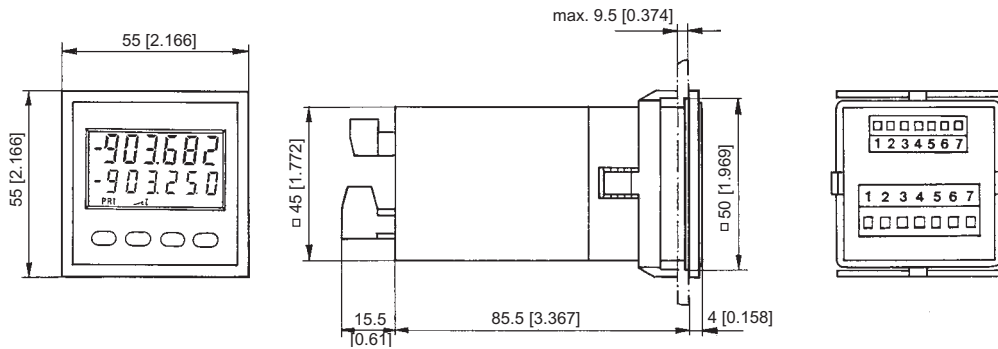

903/904 with front bezel no. 3

Panel cut-out 50 x 50 mm [1.969 x 1.969"]

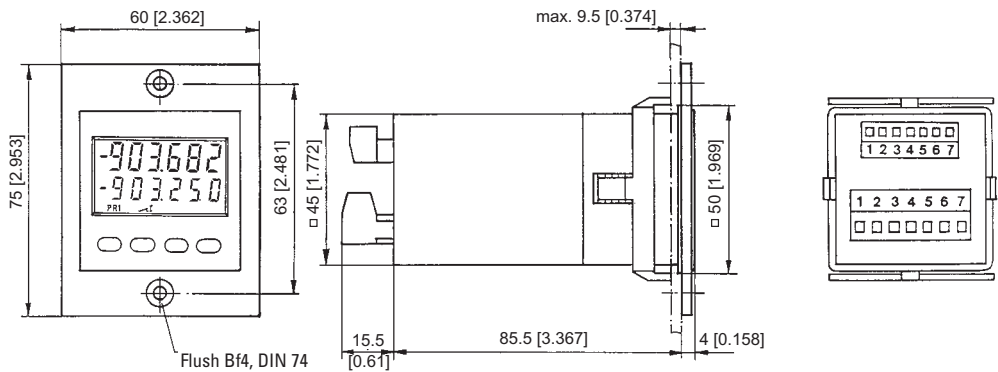

**Delivery specification:**

- Counter
- 2 Lithium batteries
- 1 Screw terminal
- 1 Front bezel for screw mounting  
Panel cut-out 50 x 50 mm [1.969 x 1.969"]

- 1 Front bezel for spring clip mount  
Panel cut-out 50 x 50 mm [1.969 x 1.969"]
- 1 Spring clip
- 1 Template for panel cut-out
- 1 Operating instruction

**Order code:**

**6.90X.01X.XXX**

**Type**  
 903 = Preset counter with one preset\*  
 904 = Preset counter with two presets\*

**Outputs**  
 0 = Relay\*  
 1 = Optocoupler

**Options**  
 00 = Without\*  
 10 = Backlit LCD\*

**Supply voltage**  
 0 = 90 ... 250 V AC\*  
 3 = 11 ... 30 V DC\*  
 5 V input level: order code: 6.XXX.01X.XXX.5V

\* standard stock model



## Type 715



### Your benefit

- 5-digit preset counter with one preset point, add./subtr.
- Bright 5-digit LED display with 7.5 mm [0.295"] high characters
- Programmable as pulse counter, frequency meter or timer
- Supply voltage: 230 V AC, 115 V AC or 11 ... 30 V DC
- approval

### Further product features

- Display range -19999 ... 9999 with zero blanking
- Easy programming of preset point; one key for each digit
- Relay or optocoupler output
- prescaling factor 0.001 ... 9.999



### Technical data:

Supply voltage:	11 ... 30 V DC, with reverse polarity protection 115 V AC, 230 V AC	switching voltage max. 250 V AC/300 V DC switching current max. 3 A, switching current for DC min. 30 mA
Current consumption:	max. 100 mA, 4 VA	switching performance: max. 50 W for DC max. 2000 VA for AC
Display:	5-digit 7-segment red LED display 7.5 mm [0.295"] high characteristics	Optocoupler: with open collector and emitter switching performance max. 30 V DC, 15 mA
Polarity of input signals:	programmable, all inputs in common	Responding time of outputs: Relay: approx. 6 ms Optocoupler: approx. 1 ms
Input resistance:	approx. 10 kΩ	Data retention: min. 10 Years or 10 <sup>6</sup> memory cycles
Count frequency:	via DIL switches separately selectable for INP A and INP B 30 Hz, 10 kHz (7.5 kHz for input mode E4) automatic reset 1 kHz without count losses (600 Hz for input mode E4)	Transmitter voltage: 24 V DC -40 %/+15 %, 80 mA unregulated for AC versions
Min. pulse length of the control inputs:	5 ms	Ambient temperature: 0 ... +50 °C [32 ... 122 °F]
Input sensitivity:	DC supply voltages: Low: 0 ... 0.2 x U <sub>B</sub> [V DC] High: 0.6 x U <sub>B</sub> ... 30 V DC AC supply voltages: Low 0 ... 4 V DC High 12 ... 30 V DC	Storage temperature: -25 ... +70 °C [-13 ... 158 °F]
Pulse shape:	variable (Schmitt Trigger characteristic)	EMC: EN 61 000-6-4/EN 55011 class B EN 61 000-6-2
Output Relay:	with potential-free change-over contact	UL certified: File E128604
		Protection: IP 65 front side
		Weight: approx. 240 g [8.466 oz], (AC-version with relay)

### Applications:

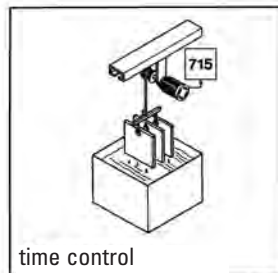
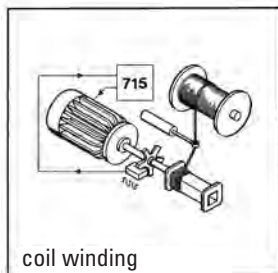
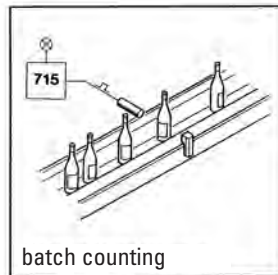
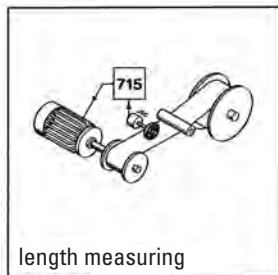

### Operating modes

Operating modes	Counting starts at	Output signal at count value	Kind of signal
1	0	≥ preset value	permanent or timed signal
2	preset value	≤ 0	permanent or timed signal
3	0	= preset value	timed signal and autom. reset
4	preset value	= 0	timed signal and autom. reset

## Selection of basic function

### 1. Pulse counter

- Mode:** see table  
**Decimal point:** 0 ... 3 decimal places (only optical function)  
**Polarity:** npn or pnp  
**Input modes:**  
 E1: One count input and one count direction input. While this input is not activated the counter adds, if it is activated the counter will subtract.  
 E2: Differential input, one up input and one down input  
 E3: Quadrature input for two lines of count pulses 90° out of phase. Up and down counting is automatic.  
 E4: Quadrature input with pulse doubling. Each pulse edge of count input "A" will be counted. Up and down counting is automatic.  
**Prescaling factor:** 0.001 ... 9.999  
**Output signal:** Permanent signal or timed signal selectable (0.01 ... 99.98 s)

### 2. Frequency counter

- Gate:** Gate time selectable from 0.001 ... 99.99 s  
**Decimal point:** 0 ... 3 decimal places  
**Polarity:** npn or pnp  
**Input modes:** see pulse counter E1 ... E4  
**Scaling factor:** 0.001 ... 9.999  
**Output signal:** Permanent or timed signal selectable (0.01 ... 99.98 s)

### 3. Timer

- Operating mode:** see pulse counter  
**Counting:** s, min or h;  
 Resolution: 0.001; 0.01; 0.1 or 1.0  
**Polarity:** npn or pnp  
**Output signal:** Permanent signal or timed signal (0.01 ... 99.98 s)

## Connection diagram:

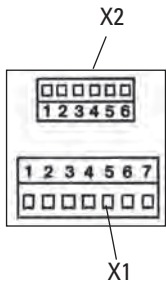

Plug connection X1:

Pin	115/230 V AC version	11 ... 30 V DC version
1	+24 V DC transmitter voltage	–
2	0 V DC (GND)	–
3	Relay output common contact (C) Optocoupler output Emitter	
4	Relay output normally open contact (NO)	
5	Relay output normally closed (NC) Optocoupler output collector	
6	115 V AC/230 V AC	11 ... 30 V DC
7	115 V AC/230 V AC	0 V DC (GND)

Plug connection X2:

Pin	Designation	Function
1	INP A	Count input A
2	INP B	Count input B
3	Gate	Gate input
4	Reset	Reset input
5	Latch	Display stop input
6	Key	Keyboard lock input

# Tachometer /Frequency meter with limits

## Dimension:

715: Panel cut-out 45 x 45 mm [1.772 x 1.772"]

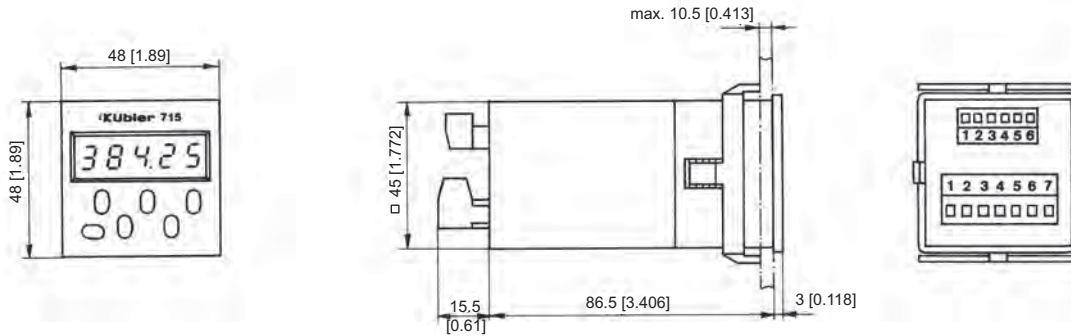

715: with front frame 2  
Panel cut-out 50 x 50 mm [1.969 x 1.969"]

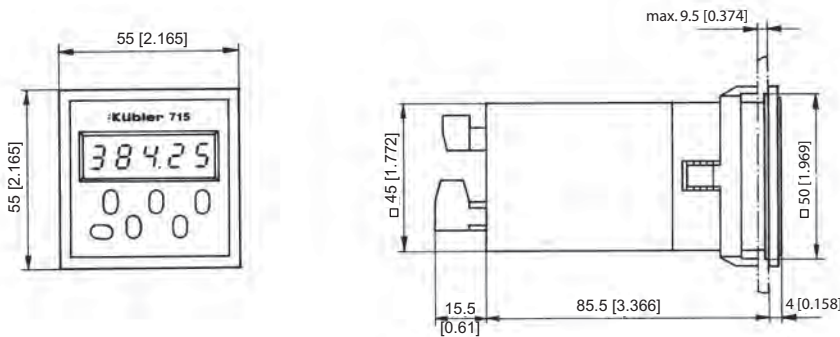

715: with front frame 3  
Panel cut-out 50 x 50 mm [1.969 x 1.969"]

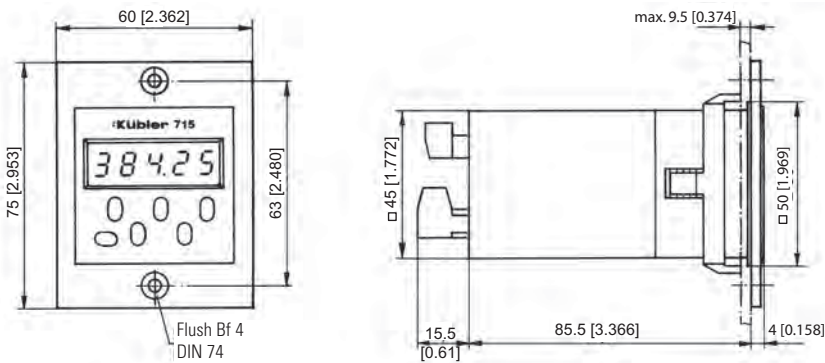

## Delivery specification:

- Counter 715
- 1 Screw terminal plug 7 pin
- 1 Screw terminal plug 6 pin
- 1 Bezel for screw mount  
panel cut-out 50 x 50 mm [1.969 x 1.969"]
- 1 Bezel for clip mount  
panel cut-out 50 x 50 mm [1.969 x 1.969"]
- 1 Panel mounting clip
- 1 Panel cut-out template
- 1 Operating manual

## Order code

6.715.01X.X00

Supply voltage  
0 = 230 V AC\*  
1 = 115 V AC\*  
3 = 11 ... 30 V DC\*

Output  
0 = Relay\*  
1 = Optocoupler

\* standard stock model

## Type 716/717 and 717 EX



### Your benefit

- Very bright 8 mm [0.315"] high display
- Programmable as a pulse counter, frequency meter or an operating time counter
- Wide range Power supply  
90 ... 260 V AC or  
10 ... 30 V DC
- approval
- -proof version

### Further product features

- Display range -199 999 ... 999 999 with zero blanking
- Easy to use and programmable with only 4 keys
- Option: serial interface  
RS 232, RS 422, RS 485
- Relay or optocoupler output
- Scaling factor 0.0001 ... 99.9999
- 716:** one preset
- 717:** two presets

### Technical data:

Supply voltage:	10 ... 30 V DC, max. 1.2 W with reverse polarity protection 90 ... 260 V AC, max. 5 VA	
Display:	6-digit 7-segment red LED; 8 mm [0.315"] high	
Counting inputs:	2 counting inputs, 4 types of programmable inputs	
Polarity of the inputs:	programmable, common for all inputs	
Input resistance:	approx. 10 k $\Omega$	
Counting frequency:	20 kHz, can be reduced to 30 Hz	
Minimum pulse duration for inputs:	5 ms	
Input switching level:	DC version: Low: 0 ... 0,2 x U <sub>B</sub> [V DC] High: 0,6 x U <sub>B</sub> ... 30 V DC AC version: Low 0 ... 4 V DC High 12 ... 30 V DC	
Pulse shape:	any shape (Schmitt-Trigger)	
Output 1 Relay:	with potential-free contacts, programmable as normally-closed (NC) or normally-open (NO) switching voltage max. 250 V AC/125 V DC, switching current max. 3 A. switching current min. at DC 30 mA switching power max. DC 90 W max. AC 750 VA	switching voltage max. 250 V AC/300 V DC, switching current max. 3 A. switching current at DC min. 30 mA switching power at DC 50 W at AC max. 2000 VA
or npn optocoupler:	with open collector and emitter switching power 30 V DC/15 mA	with open collector and emitter switching power 30 V DC/15 mA
Output 2 Relay:	with potential free switching contact, programmable opening or closing.	
Accuracy:	<0,1 % (at frequency meter mode) $\pm$ 50 ppm (at time counter mode)	
Output response time:	Relay: approx. 7 ms Optocoupler: approx. 2 ms	
Data storage:	min. 10 years or 10 <sup>8</sup> memory cycles	
Transmitter voltage:	24 V DC -40 %/+15 %, 100 mA at AC version	
Ambient temperature:	-10 ... +50 °C [14 ... 122 °F]	
Storage temperature:	-25 ... +70 °C [-13 ... 158 °F]	
EMC:	according to EC EMC directive 89/36/EWG	
Emitted interference:	EN 61 000-6-4/EN 55011 class B	
Immunity to interference:	EN 61 000-6-2	
Protection:	IP 65 front side EX-proof IP54	
Weight:	approx. 200 g [7.055 oz] Ex-execution 2 kg [70.548 oz]	
only for EX proof:	Counter in EX proof version acc. to explosion-proof class EEx D IIC T6, with encapsulated cable 2 x 3 m [2.188 x 3.281 yards] PTB approval no. Ex-96.D. 1024 hardcoated AL-housing function mode as type 717 Note: the EX-proof version has an additional fuse.	

### Inputs:

#### 2 counting inputs

The maximum frequency is 20 kHz (20 kHz in the phase discriminator mode); it can be reduced to 30 Hz.

#### Gate

##### Static gate input

pulse count mode: no counting, when the input is active  
timer mode: Counting when active gate.lo or not activated gate.hi programmable

#### Reset

Dynamic reset input with the same function as the reset key. Resets the counter to zero, when counting up and sets it to the preset value when counting down

#### Key

Static key lock input. The keys are locked as long as this input is on. The preselection display key remains active

### Interfaces:

The devices can be fitted with the optional RS 232, RS422 or with the RS 485 interfaces. These interfaces can be used to program the devices as well as for remote reading. They are simply controlled by ESC sequences, max. 4800 Baud

### Programming:

The counters 716/717 are programmed by means of the 4 front keys. The operator guidance on this display allows a simple and intuitive programming. All settings can be carried out by selecting the corresponding parameters in this menu.

The follow modes can be programmed

1. Pulse counter
2. Frequency meter
3. Time meter

### Programmable are:

#### Input polarity:

Positive (pnp) or negative (npn). The selection is valid for all inputs

#### Pulse or time counting modes:

- adding with counting; start at 0
- subtracting with counting start at the preset (716) and at preselection 2 (717)
- adding with automatic reset when the preset (716) or the preset 2 (717) is reached
- subtracting with automatic positioning at the preset (716) or preset 2 (717) when 0 is reached

#### Input types in pulse counter mode:

- Cnt.Dir 1 counting input
- 1 counting direction input
- uP.dn Differential counting
- 1 adding input
- 1 subtracting input

- quad Phase discriminator to connect encoders with 2 signals shifted by 90°
- quad2 Phase discriminator with double pulse processing, to connect pulse sources with 2 signals shifted by 90°

### Decimal places:

Data can be displayed with one, two or three decimal places.

### Factor:

For an optimum matching of the measuring signal, the displayed values can be weighted by a scale factor between 0.0001 and 99.9999.

### Output signal:

The function of the output signal can be preselected (independently for both outputs of model 717) as a normally closed, normally open or a negative pulse signal.

### Maximum counting frequency:

The maximum counting frequency can be set to 30 Hz or 20 kHz.

### Timer:

Counting can be carried out in h, min, s or in h:min:s. The number of decimal places determines the resolution. A resolution up to the ms-range can be achieved.

### Connection diagram:

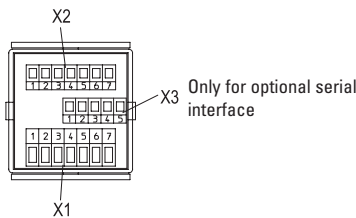

Pin connection X2:

Pin	description	AC version	DC-Version
1	+24 V DC	Power supply	n.c.
2	0 V DC (GND)	GND	n.c.
3	INP A	Count input A	
4	INP B	Count input B	
5	Reset	Reset input	
6	Gate	Gate input	
7	Key	Input for key lock	

Pin connection X1:

Pin	AC version	DC version
1	Output1 Relay Collector for optocoupler output	
2	Output 1 Relay Emitter for optocoupler output	
3	Output 2 Relay common contact (C) Emitter for optocoupler output	
4	Output 2 Relay closing contact (NO)	
5	Output 2 Relay opening contact (NC) Collector for optocoupler-output	
6	Power supply 90 ... 250 V AC	10 ... 30 V DC
7	90 ... 250 V AC	0 V DC (GND)

Pin connection X3:

PIN No.	RS232	RS 422	RS 485
1	GND	-	-
2	RxD	RI+	DO/RI+
3	TxD	RI-	DO/RI-
4	RTS	DO+	-
5	CTS	DO-	-



- Easy parameter software for counter type 716/717 and process displays 55x.
- Upload and download function
- Monitor- and terminal program for easy diagnostic functions
- Online display of the measurement values
- German and English.

## Dimensions:

717

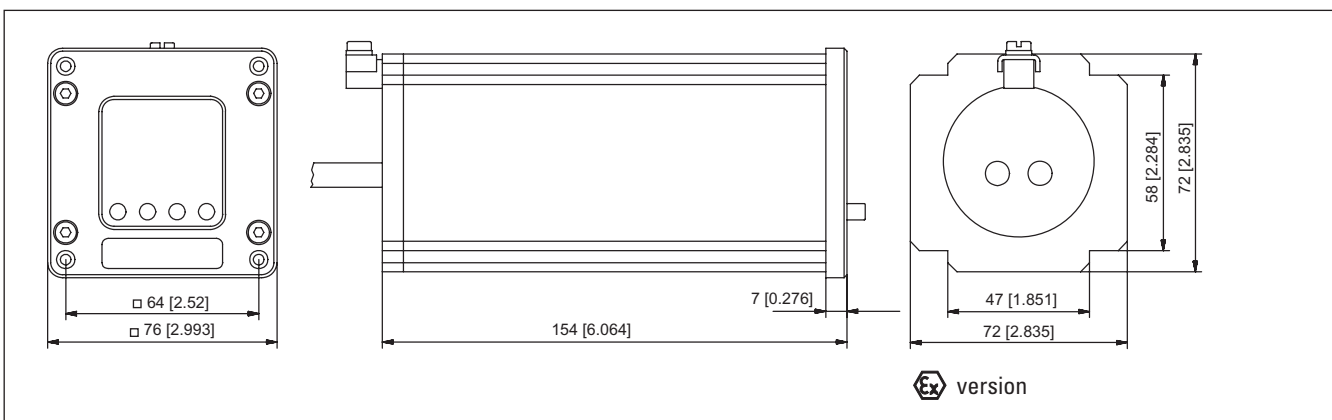
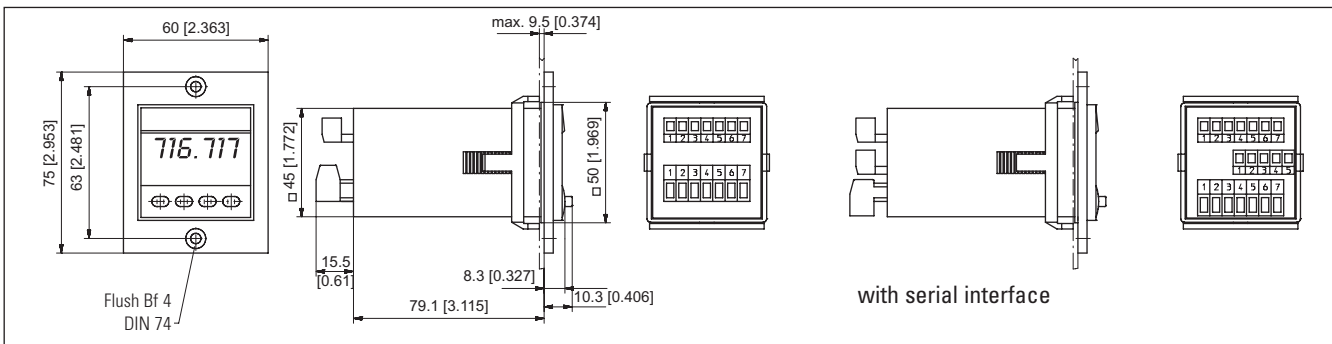
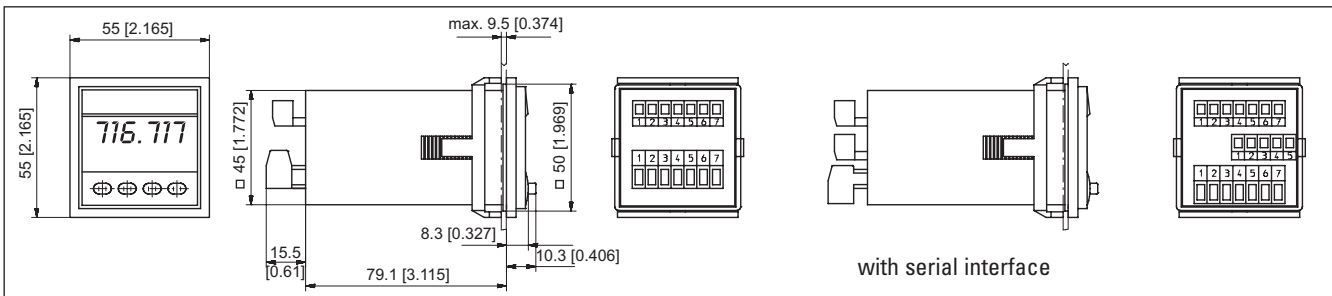
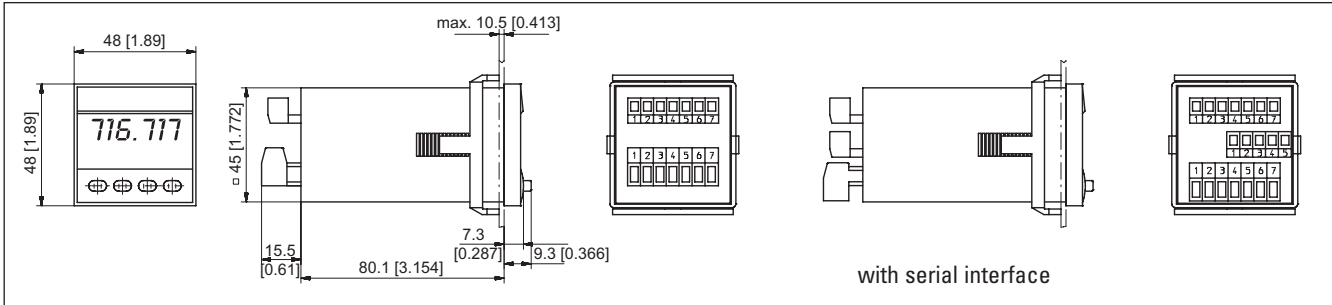

# Tachometer /Frequency meter with limits

## Delivery specification: 716/717

- |   |  |
|---|--|
| Counter 716/717   | 1 Frame for clip mounting<br>panel cut-out 50 x 50 mm [1.969 x 1.969"] |
| 1 Screw terminal 7 poles, RM 5.08                                       | 1 Mounting clip  |
| 1 Screw terminal 7 poles, RM 3.81                                       | 1 Template for cut-out   |
| 1 Frame for screw mounting<br>panel cut-out 50 x 50 mm [1.969 x 1.969"] | 1 Operating instructions   |

## Order code:

**6.71X.01X.XXX**

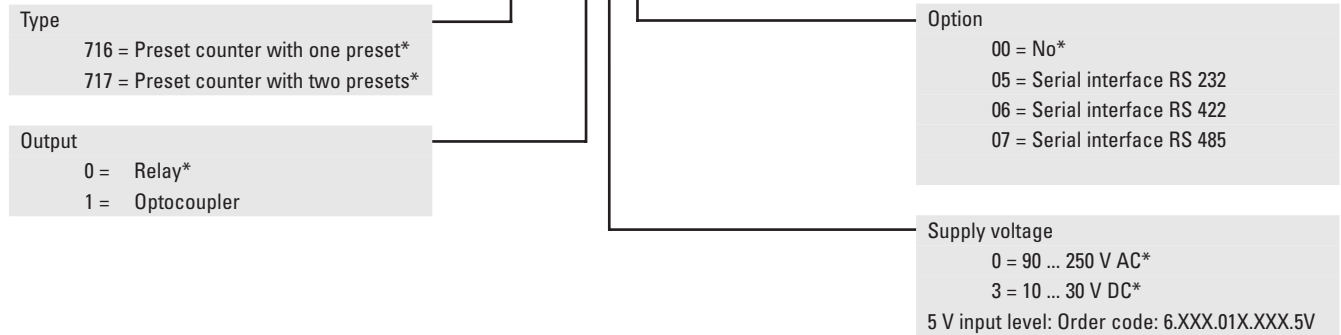

\* standard stock model

## Delivery specification: 717 Ex

Counter 717 in Ex-proof housing acc. to explosion-proof class EEx D IIC T6 with encapsulated cable 2 x 3 m [2.188 x 3.281 yards], various mounting parts, PTB approval certificate

## Order code for Ex proof version:

**6.717.010.X00.Ex**

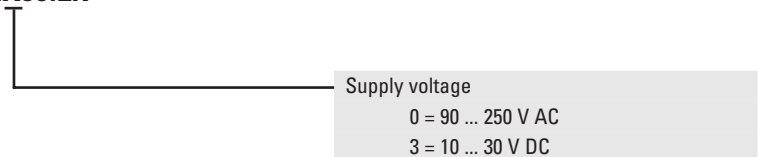

## Display Type 571



### Your benefit

- AC and DC supply voltage in one unit
- Measuring function can be programmed for RPM, speed (from elapsed time), machine cycle time, throughput and baking time (time interval), as well as numerous count and stop-watch functions
- Scaleable display, programmed via 2 keys
- Large 15 mm [0.591"] high LED-display, 6-digit, with adjustable brightness

### Product features

- Fast count input, works with our **LIMES** measuring system (100KHz)
- Version with 2 optocoupler outputs for alarms
- Version with analogue output, resolution 14 Bit: 0 ... 10 V, +10 V ... -10 V, 0 ... 20 mA, 4 ... 20 mA
- Version with serial interface RS232/485 for importing and exporting data
- 48 x 96 mm [1.89 x 3.78"] DIN housing, IP 65

### Technical data:

Supply voltage:	16 ... 35 V DC (Normal voltage: 24 V DC) 115/230 V AC $\pm$ 12,5 %
Display:	15 mm [0.591"] high LED-display, 6 digits
Current consumption [DC]:	18 V: 120 mA; 24 V: 95 mA; 30 V: 80 mA
Power consumption [AC]:	7.5 VA
Sensor power supply:	24 V DC $\pm$ 15%, 120 mA (at AC and DC supply)
<b>Inputs:</b>	3 Inputs (PNP, NPN and Namur) A, B = Impulse, C = Reset
Max. input frequency:	A, B = 25 kHz (100 kHz at count); C = 1 kHz
(Accuracy:	$\pm$ 1 ppm $\pm$ 1 digit
Input level HTL:	Low: 0 ... 3,5 V High: 9 ... 35 V

<b>Outputs:</b>	
Analogue-Output: (0.571.012.E90)	0 ... +10 V, 0 ... -10 V and 0 ... 20 mA, 4 ... 20mA
Resolution:	14 Bit + Sign
Accuracy:	0,1 %
Optocoupler-Output: (0.571.011.E00)	5 ... 35 V DC/150 mA
Interface (0.571.012.E05)	RS232 and RS485 acc. to ISO 1745 Drivecom Protocol
Operating temperature:	0 ... +45 °C [32 °F ... 113 °F]
Storage temperature:	-25 ... +70 °C [-13 °F ... 158 °F]
Protection:	IP 65 front side
EMC:	according to EC EMC directive 89/36/EWG
Interference emission:	EN 50081-2/EN 55011 class B
Interference resistance:	EN 6100-6-2
Weight:	approx. 200 g [7.055 oz]

### Dimensions:

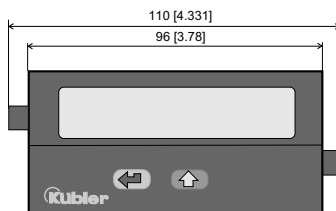

Panel cut out: 91 x 44 mm [3.583 x 1.732]

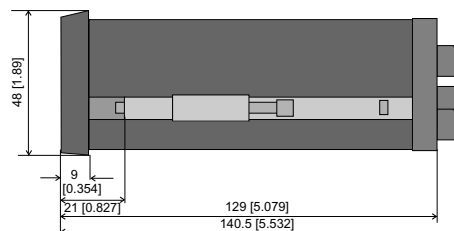

Display with serial interface (0.571.012.E05)

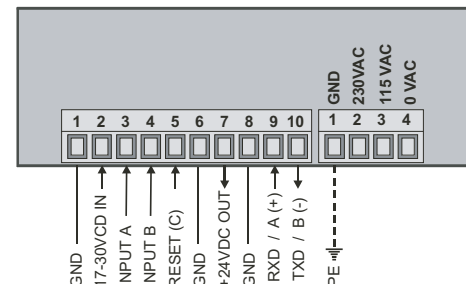

### Terminal assignment:

Display with analogue output (0.571.012.E90)

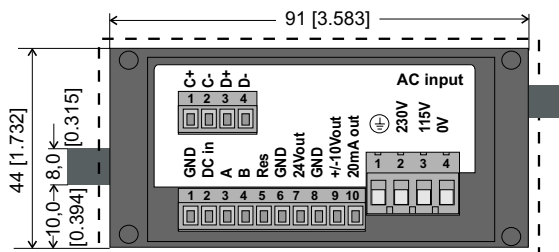

Display with 2 optocoupler outputs (0.571.011.E00)

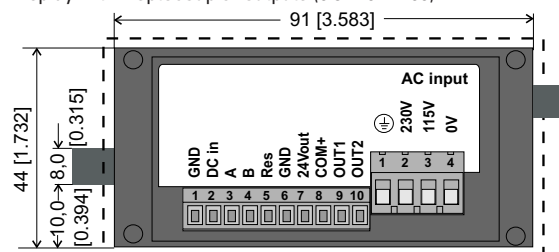

### Delivery specifications:

- Display 571
- Mounting kit
- Seal
- Plug-in screw terminals
- Manual German/English

### Order data:

- Display with 2 outputs Order code: 0.571.011.E00\*
- Display with analogue output Order code: 0.571.012.E90\*
- Display with ser. interface Order code: 0.571.012.E05



## Table of Contents

Type of counter	Series	Display	Panel cut-out W x H [mm]	Reset			Remarks	Page	
				without	man.	electr.			
Position display	LCD	Codix 133	99999999	45 x 22	–	•	•	Position display	266
	LED	Codix 521	999999	45 x 22	–	•	•	Totaliser and position display	268
		Codix 524	999999	45 x 22	–	•	•	Multifunction	270
		Codix 52P	999999	45 x 22	–	•	•	Position- and frequency display	272
		Codix 541	999999	92 x 45	–	•	•	Totaliser and position display	274
		Codix 544	999999	92 x 45	–	•	•	Multifunction	276
		Codix 54P	999999	92 x 45	–	•	•	Position- and frequency display	278
	LCD	923/924	999999	92 x 45	–	•	•	Panel mount, AC or DC-supply with options	280
	LED multi.	571	999999	92 x 45	–	•	•	Panel mount, multifunction	286
	SSI	570	999999	92 x 45	–	•	•	SSI display	287

## LCD Display counter **CODIX 133**



- Low-price and high efficiency
- Large 8-digit LCD display, height of the figures 8 mm [0.315"]
- Optional backlighting
- Counting modes include phase discriminator (quadrature) counting (also with pulse doubling) for connection to incremental encoders
- Unified Codix design, matches the extensive **CODIX** family
- IP 65
- Screw terminals, RM 5 mm [0.197"]
- Lifetime of the battery approximately 8 years
- Locking of the reset key
- Ambient temperature -10 ... +60 °C [14 ... 140 °F]
- All versions for positive or negative counting edge

### Technical data:

Power supply:	non-replaceable lithium battery (lifetime approximately 8 years at 20°C [68 °F])
Backlighting:	external electrical source 24 V DC +/- 20 %, 50 mA
Display:	LCD, 8-digits, height of the figures 8 mm [0.315"]
Mode:	adding or subtracting (selectable) counting direction differential counting or phase discriminator single or dual evaluation, selectable
Display range:	-9999999 ... 99999999, with overflow display
Reset:	manual and electrical
UL certified:	File: E128604
Interference emissions:	EN 55011 Class B, EN 61000-6-2 EN 61010 Section 1 (only AC versions)
Housing:	dark grey RAL 7021
Operating temperature:	-10 ... +55 °C [14 ... 131 °F]
Ambient temperature:	-10 ... +60 °C [14 ... 140 °F]
Storage temperature:	-20 ... +70 °C [-4 ... 158 °F]
Protection:	IP 65 front side
Weight:	approx. 50 g [1.764 oz]

### Counting inputs:

Counting input of the DC-versions (max. 30 V DC)	
Slow counting input:	max. 30 Hz NPN
Fast counting input:	max. 12 kHz (PNP), 7 kHz (NPN)
Switching level:	NPN: Low: 0 ... 0.7 V, High: 3 ... 30 V DC PNP: Low: 0 ... 0.7 V, High: 4 ... 30 V DC
Switching	x1 or x2 evaluation
Contact input:	Open Collector NPN (switching at 0 V DC)
Switching level:	NPN: Low: 0 ... 0.7 V, High: 3 ... 5 V DC
Reset Input (only DC and high voltage)	
Minimum pulse time:	DC: 50 ms, high voltage: 16 ms
Contact input DC:	NPN: Low: 0 ... 0.7 V, High: 3 ... 30 V DC
Electrical reset key locking (for DC and AC)	
Contact input:	Open Collector NPN (switching at 0 V)
Switching level:	NPN: Low: 0 ... 0.7 V, High: 3 ... 5 V DC

### Connection diagram:

**DC type:**  
6.133.012.8x0

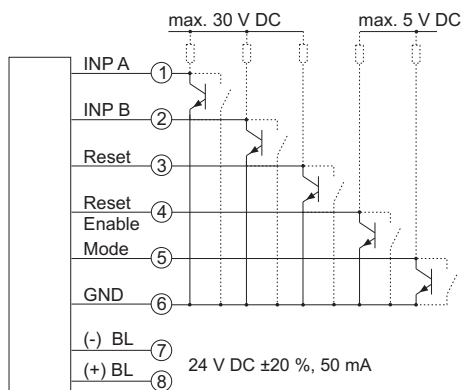

**DC type:**  
6.133.012.8x1

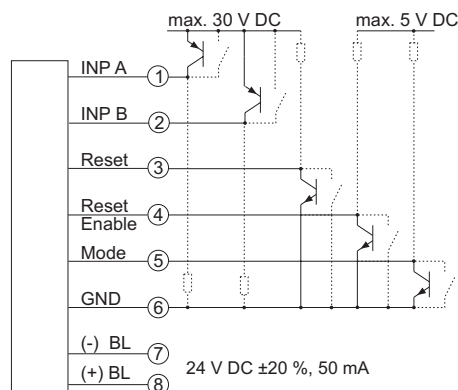

## LCD Display counter **CODIX 133**

### Dimensions:

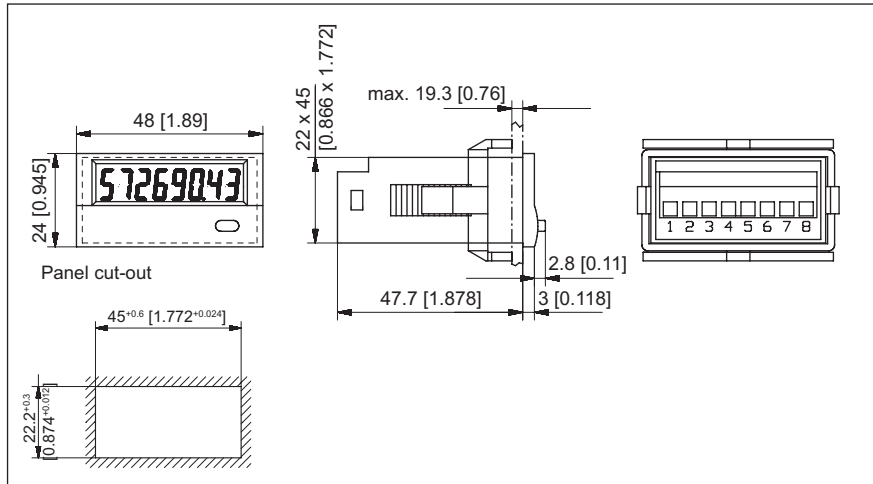

### Dimensions for bezels (included in delivery)

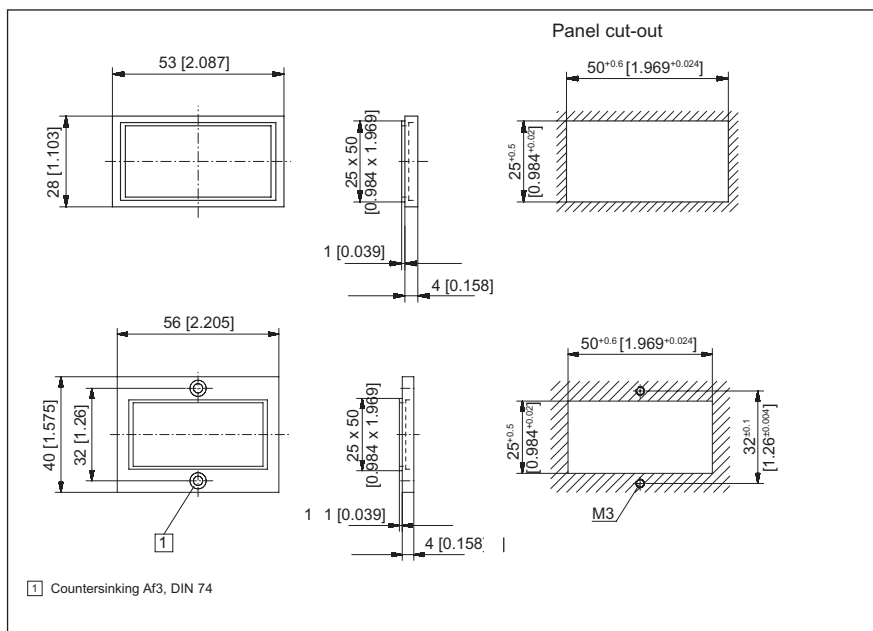

### Delivery specification:

- Digital display
- Panel mounting clip
- Bezel for screw mounting (56 x 40 mm) [2.205 x 1.575"], panel cut out 50 x 25 mm [1.969 x 0.984"]
- Bezel for clip mounting (53 x 28 mm) [2.087 x 1.103"], panel cut out 50 x 25 mm [1.969 x 0.984"]
- Seal
- Operating instructions

### Order code:

Type	Input type	Count inputs							
		INP A				INP B			
6.133.012.8x0*	Quad <sup>4</sup> /Quad <sup>25</sup>	0 ... 0.7 V DC	channel A	NPN	3 kHz	0 ... 0.7 V DC	channel B	NPN	3 kHz
6.133.012.8x1*		4 ... 30 V DC	channel A	PNP	6 kHz	4 ... 30 V DC	channel B	PNP	6 kHz

X: 5 = no backlight  
X: 6 = with backlight

4) Phase discriminator for incremental encoders with x1 evaluation

5) Phase discriminator for incremental encoders with x2 evaluation  
\* standard stock model

## Position indicator or totaliser **CODIX 521**

### 4 count modes:

- Count with direction
- Count difference
- Count sum of 2 inputs
- Phase discriminator (quadrature) x1, x2 and x4

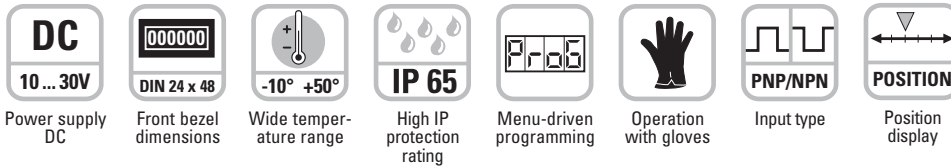

### Powerful

- **Fast count input**  
Input frequency max. 60 kHz
- **Robust housing**  
IP 65 protection
- **LED display**  
Very bright, 8 mm high
- **Position, difference, adding or detection of count direction**  
Programmable for positive (PNP) or negative (NPN) switching input pulses  
Fast count input with an input frequency of max. 60 kHz, can be damped to 30 Hz for mechanical contacts
- **Fast start-up time**  
Detects incoming pulses just 16 ms after being switched on – so no pulses are lost with a simultaneous motor start-up



### User-friendly

- **Big keys**  
Can also be operated when using gloves
- **Easy to programme**  
Easy menu-driven programming and operation  
Possibility to enter the programming mode during operation, with authentication query

### Universal

- **Individually programmable scaling**  
Multiplication and division factor (0.0001 to 99.9999), to display corresponding engineering units, e.g. position in 1/10 mm and speed in RPM
- **4 different count input modes**  
2-channel input for detecting count direction, difference or adding mode, quadrature x1, x2 or x4
- **Programmable setpoint**
- **DC power supply**
- **Inputs**  
As an alternative to the HTL inputs, devices with a 5 VDC input trigger level are available, for use as parallel displays for PLCs.
- **Optional output**  
As zero signal

## Applications for Position Displays and Totalisers

- Positioning tasks on processing machines, such as sawing machines, milling machines, bending and folding machines, etc.
- Production data acquisition by means of piece counting (using difference or adding)
- Totalizing flow, quantity and other scaleable media
- Counting tasks such as quantity and piece counting
- Accessories, OEM equipment or retrofitting to production machines
- Piece counting on die cutters, presses, extruders, woodworking machines, drilling machines, pick-and-place machines, guillotines, special-purpose vehicles etc.

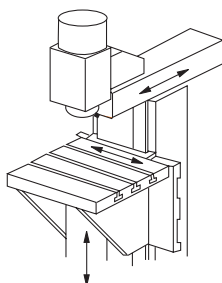

Position on milling machine

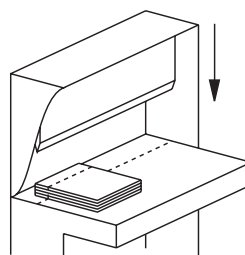

Position or quantity

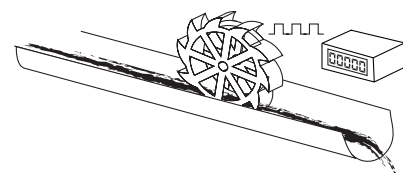

Flow rate

## Position indicator or totaliser **CODIX 521**

### Technical data:

Supply voltage:	10 ... 30 V DC, with reverse polarity protection	Level of inputs:	Low: 0 ... 0.2 x U <sub>B</sub> [V DC] High: 0.6 x U <sub>B</sub> ... 30 V DC
Current consumption:	max. 50 mA	Level of inputs:	Low: 0 ... 2 V DC High: 4 ... 30 V DC
Display:	6 digit red 7-segment LED; 8 mm [0.315"] high	5 V version	High: 4 ... 30 V DC
Data backup:	EEPROM	Optocoupler output:	Max. 30 V, 10 mA
Housing:	Dimension 48 x 24 mm [1.89 x 0.945"] according to DIN 43 700; RAL 7021, grey	EMC:	according to EC EMC directive 89/36/EWG
Polarity of inputs:	programmable, npn or pnp for all inputs	Immunity to interference:	EN 61000-6-4/EN 55011 class B
Input resistance:	approx. 5 kΩ	Emitted interference:	EN 61000-6-2
Counting frequency:	60 kHz, can be damped to 30 Hz	Ambient temperature:	-10 ... +50 °C [14 ... 122 °F]
Reset time:	5 ms	Storage temperature:	-25 ... +70 °C [-13 ... 158 °F]
		Protection:	IP65 front side
		Weight:	approx. 50 g [1.764 oz]

### Block diagram:

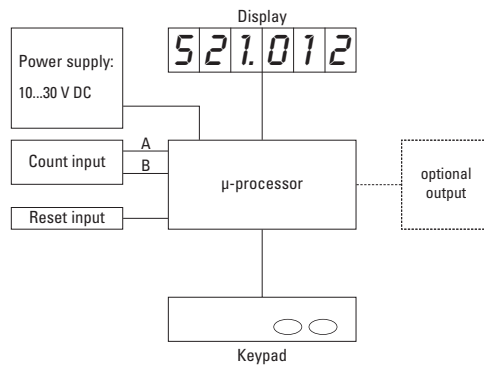

### Dimensions:

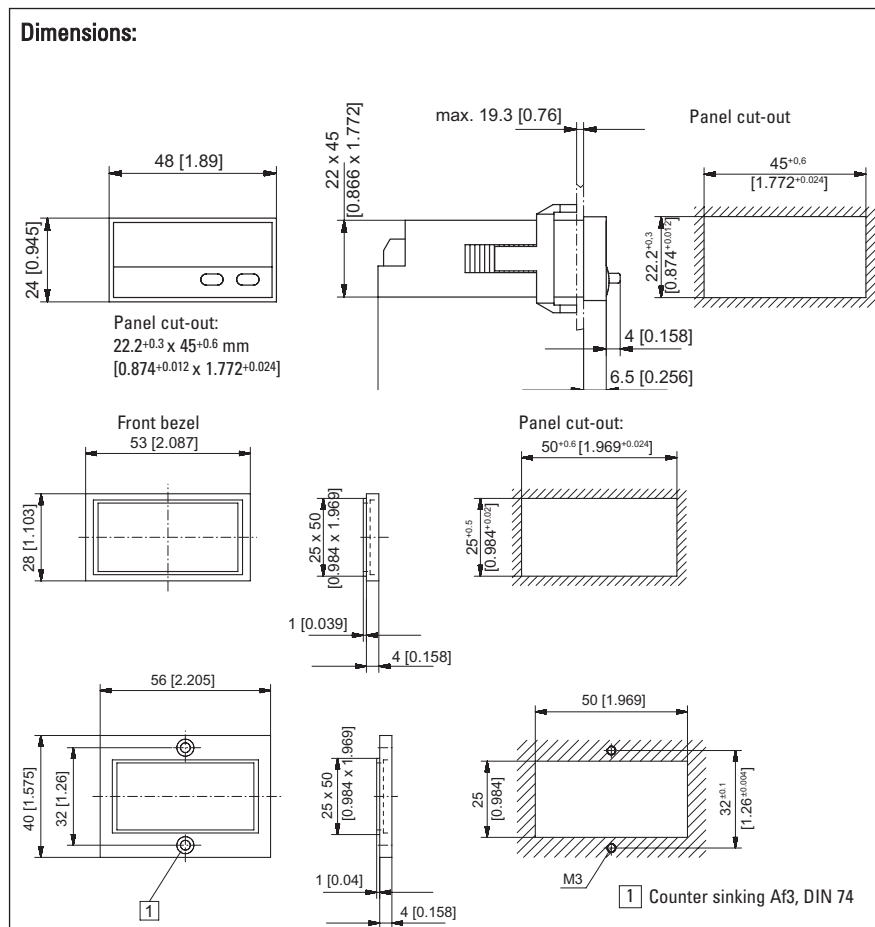

### Connections:

without optocoupler

- 1 10 ... 30 V DC
- 2 0 V GND
- 3 INP A
- 4 INP B
- 5 Reset



### Connections:

with optocoupler

- 1 10 ... 30 V DC
- 2 0 V GND
- 3 INP A
- 4 INP B
- 5 RESET
- 6 Emitter
- 7 Collector

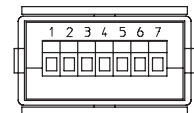

### Delivery specifications:

- 1 Digital display
- 1 Panel mounting clip
- 1 Bezel for screw mounting, panel cut out 50 x 25 mm [1.969 x 0.984"]
- 1 Bezel for clip mounting, panel cut out 50 x 25 mm [1.969 x 0.984"]
- 1 Seal
- 1 Multilingual operating instructions

### Order code:

6.521.01X.3X0

- Input switch level
- 0 = Standard\*
- A = 5 V
- Output
- 1 = Optocoupler
- 2 = No output

\* standard stock model

## Multifunction display **CODIX 524**

programmable as:

- Pulse counter
- Position display
- Frequency / speed display
- Timer/ short time meter

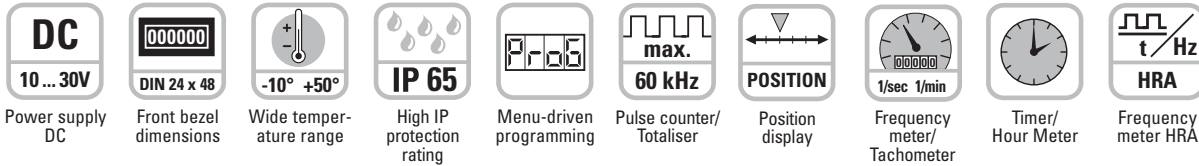

### Powerful

- **Fast count input**  
Input frequency max. 60 kHz
- **Robust housing**  
IP 65 protection
- **LED display**  
Very bright, 8 mm high
- **HRA – High Rate Accuracy System**  
Frequencies up to 38 Hz are calculated using time-interval (period duration) measurement.  
Frequencies > 38 Hz are calculated using a special time base (gate time) measurement. A very high accuracy of > 0.1% is achieved, even with very short gate times. The resulting measurement is available after a max. of 50 ms.
- **Fast start-up time**  
Detects incoming pulses just 16 ms after being switched on – so no pulses are lost with a simultaneous motor start-up



### User-friendly

- **Big keys**  
Can also be operated when using gloves
- **Easy to programme**  
Easy menu-driven programming and operation  
Possibility to enter the programming mode during operation, with authentication query

### Universal

- **Individually programmable scaling**  
Multiplication and division factor (0.0001 to 99.9999), to display corresponding engineering units, e.g. position in 1/10 mm and speed in RPM
- **4 different count input modes**  
2-channel input for detecting count direction, difference or adding mode, quadrature x1, x2 or x4
- **Frequency measurement**  
Display in 1/min or 1/sec
- **Time counting**  
Pulse width or time interval measurement in hours, minutes or seconds, as well as real-time display
- **DC power supply**
- **Inputs**  
As an alternative to the HTL inputs, devices with a 5 VDC input trigger level are available, for use as parallel displays for PLCs.
- **Optional output**  
Zero signal for position and count, zero-speed monitoring, 1 Hz clock pulse for active time measurement

### Applications for Multi-function Display

- Counting tasks such as quantity and piece counting, measuring and recording of speed and of operating and processing times
- Piece counting or tool-life measurement on die cutters, presses, extruders, wood-working machines, drilling machines,

- pick-and-place machines, guillotines, special-purpose vehicles etc.
- Positioning tasks on processing machines, such as sawing machines, milling machines, bending and folding machines, etc.

- Production data acquisition by means of piece counting (using difference or adding), or measurement of production times or production speeds
- Totalizing flow, quantity and other scaleable media, or display of current flow rates

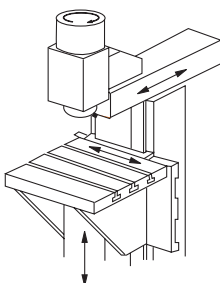

Position or rotary speed on milling machine

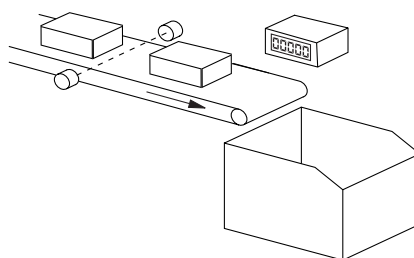

Piece count on conveyor or production speed

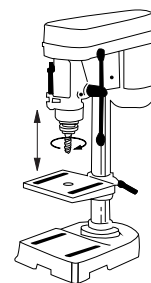

Drilling machine head, speed or drilling depth

## Multifunction display *CODIX 524*

### Technical data:

Supply voltage:	10 ... 30 V DC, with reverse polarity protection	Level of inputs:	Low: 0 ... 0.2 x U <sub>B</sub> [V DC] High: 0.6 x U <sub>B</sub> ... 30 V DC
Current consumption:	max. 50 mA	Level of inputs:	Low: 0 ... 2 V DC
Display:	6 digit red 7-segment LED; 8 mm [0.315"] high	5 V version:	High: 4 ... 30 V DC
Data backup:	EEPROM	Optocoupler output:	Max. 30 V, 10 mA
Housing:	dimension 48 x 24 mm [1.89 x 0.945"] according to DIN 43 700; RAL 7021, grey	Accuracy:	tachometer: <0.1 % timer: 50 ppm
Polarity of inputs:	programmable, npn or pnp for all inputs	EMC:	according to EC EMC directive 89/36/EWG
Input resistance:	approx. 5 kΩ	Immunity to interference:	EN 61000-6-4/EN 55011 class B
Counting frequency:	60 kHz, can be damped to 30 Hz	Emitted interference:	EN 61000-6-2
Display range timer:	0.001 s ... 999999 h	Ambient temperature:	-10 ... +50 °C [14 ... 122 °F]
Reset time:	5 ms	Storage temperature:	-25 ... +70 °C [-13 ... 158 °F]
		Protection:	IP 65 front side
		Weight:	approx. 50 g [1.764 oz]

### Block diagram:

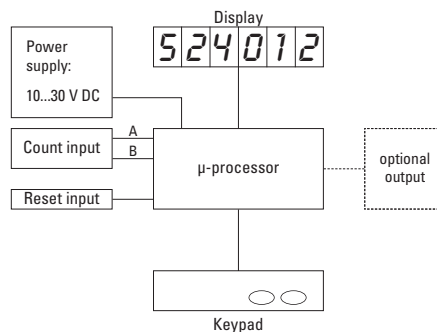

### Dimensions:

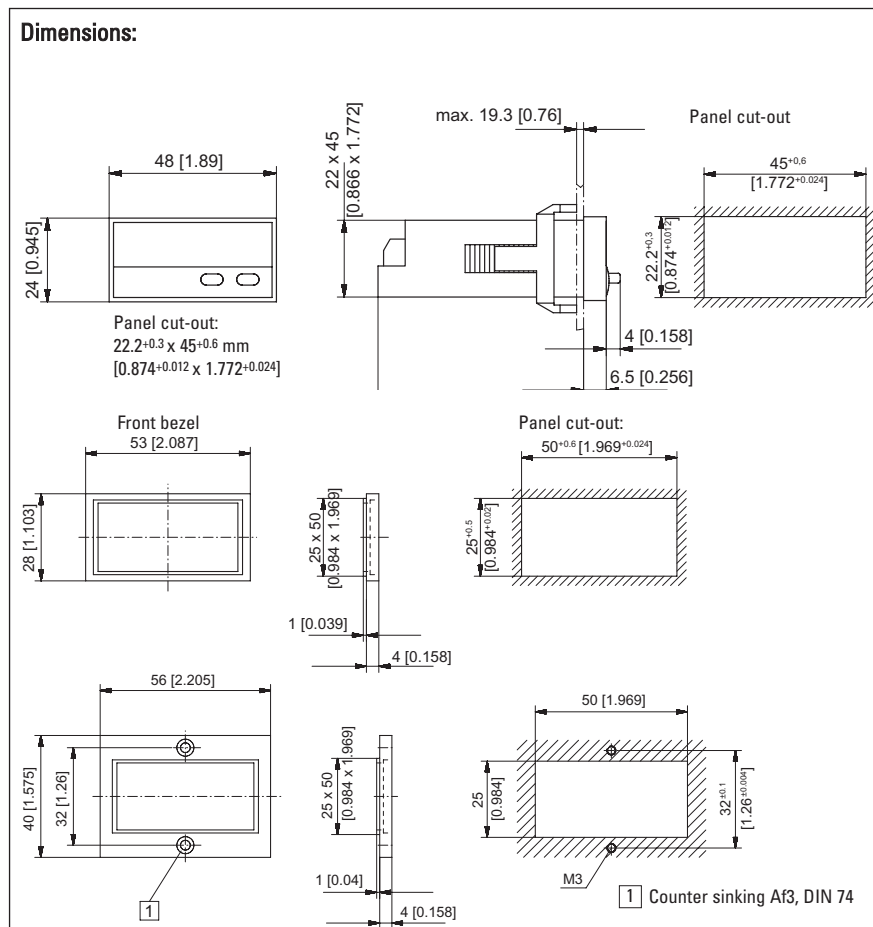

### Connections:

without optocoupler

- 1 10 ... 30 V DC
- 2 0 V GND
- 3 INP A
- 4 INP B
- 5 Reset

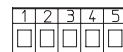

### Connections:

with optocoupler

- 1 10 ... 30 V DC
- 2 0 V GND
- 3 INP A
- 4 INP B
- 5 RESET
- 6 Emitter
- 7 Collector

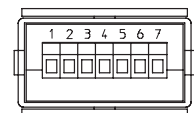

### Delivery specifications:

- 1 Digital display
- 1 Panel mounting clip
- 1 Bezel for screw mounting, panel cut out 50 x 25 mm [1.969 x 0.984"]
- 1 Bezel for clip mounting, panel cut out 50 x 25 mm [1.969 x 0.984"]
- 1 Seal
- 1 Multilingual operating instructions

### Order code:

6.524.01X.3X0

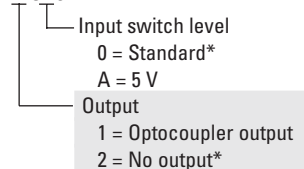

\* standard stock model

## Position and Frequency display **CODIX 52P**

separate inputs for frequency and position

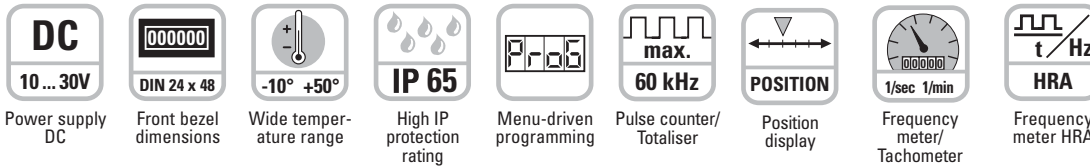

### Powerful

- **Fast count input**  
Input frequency max. 60 kHz
- **Robust housing**  
IP 65 protection
- **LED display**  
Very bright, 8 mm high
- **HRA – High Rate Accuracy System**  
Frequencies up to 38 Hz are calculated using time-interval (period duration) measurement.  
Frequencies > 38 Hz are calculated using a special time base (gate time) measurement. A very high accuracy of > 0.1% is achieved, even with very short gate times. The resulting measurement is available after a max. of 50 ms.
- **Fast start-up time**  
Detects incoming pulses just 16 ms after being switched on – so no pulses are lost with a simultaneous motor start-up



### User-friendly

- **Big keys**  
Can also be operated when using gloves
- **Easy to programme**  
Easy menu-driven programming and operation  
Possibility to enter the programming mode during operation, with authentication query  
Pressing the right key switches between displays

### Universal

- **Individually programmable scaling**  
Multiplication and division factor (0.0001 to 99.9999), to display corresponding engineering units, e.g. position in 1/10 mm and speed in RPM.
- **Separate factors and inputs for frequency- and pulse counting**
- **4 different count input modes for the position display**  
2-channel input for detecting count direction, difference or adding mode, quadrature x1, x2 or x4. 1 separate input for rotary speed and speed, display in 1/min or 1/sec
- **DC supply**
- **Inputs**  
As an alternative to the HTL inputs, devices with a 5 VDC input trigger level are available, for use as parallel displays for PLCs.

### Applications for Frequency and Position Display/ Totaliser

Position and rotary speed applications, e.g.

- OEM equipment or retrofitting to drilling machines
- OEM equipment on flow measuring plant, e.g. total flow and current flow

- Total piece count and pieces per minute, where the pulse counting occurs in the add/subtract mode, in order to deduct reject parts

- Production data acquisition: total piece count and production speed, or absolute distance traversed and current speed

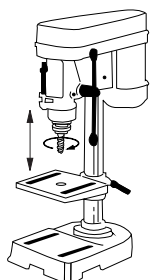

Rotary speed and drilling depth

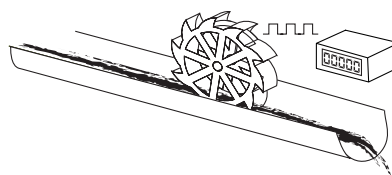

Flow rate and total volume

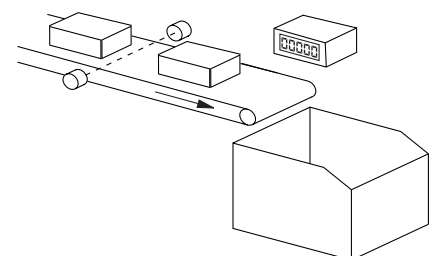

Piece count on conveyor and production speed



## Position and Frequency display **CODIX 52P**

### Technical data:

Supply voltage:	10 ... 30 V DC, with reverse polarity protection	Level of inputs:	Low: 0 ... 0.2 x U <sub>B</sub> [V DC] High: 0.6 x U <sub>B</sub> ... 30 V DC
Current consumption:	max. 40 mA	Level of inputs: 5 V version	Low: 0 ... 2 V DC High: 4 ... 30 V DC
Display:	6 digit red 7-segment LED; 8 mm [0.315"] high	Accuracy:	<0.1 % (Frequency display, tachometer)
Data backup:	EEPROM	EMC:	according to EC EMC directive 89/36/EWG
Housing:	dimension 48 x 24 mm [1.89 x 0.945"] according to DIN 43 700; RAL 7021, grey	Immunity to interference:	EN 61000-6-4/EN 55011 class B
Polarity of inputs:	programmable, npn or pnp for all inputs	Emitted interference:	EN 61000-6-2
Input resistance:	approx. 5 kΩ	Ambient temperature:	-10 ... +50 °C [14 ... 122 °F]
Counting frequency:	30 kHz, can be damped to 30 Hz	Storage temperature:	-25 ... +70 °C [-13 ... 158 °F]
Reset time:	5 ms	Protection:	IP 65 front side
		Weight:	approx. 50 g [1.764 oz]

### Block diagram:

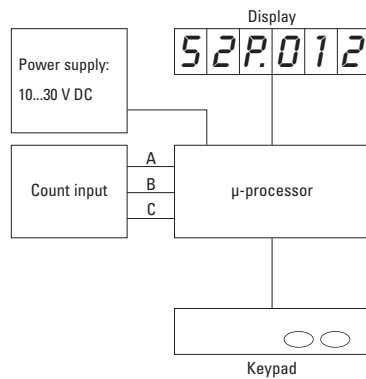

### Dimensions:

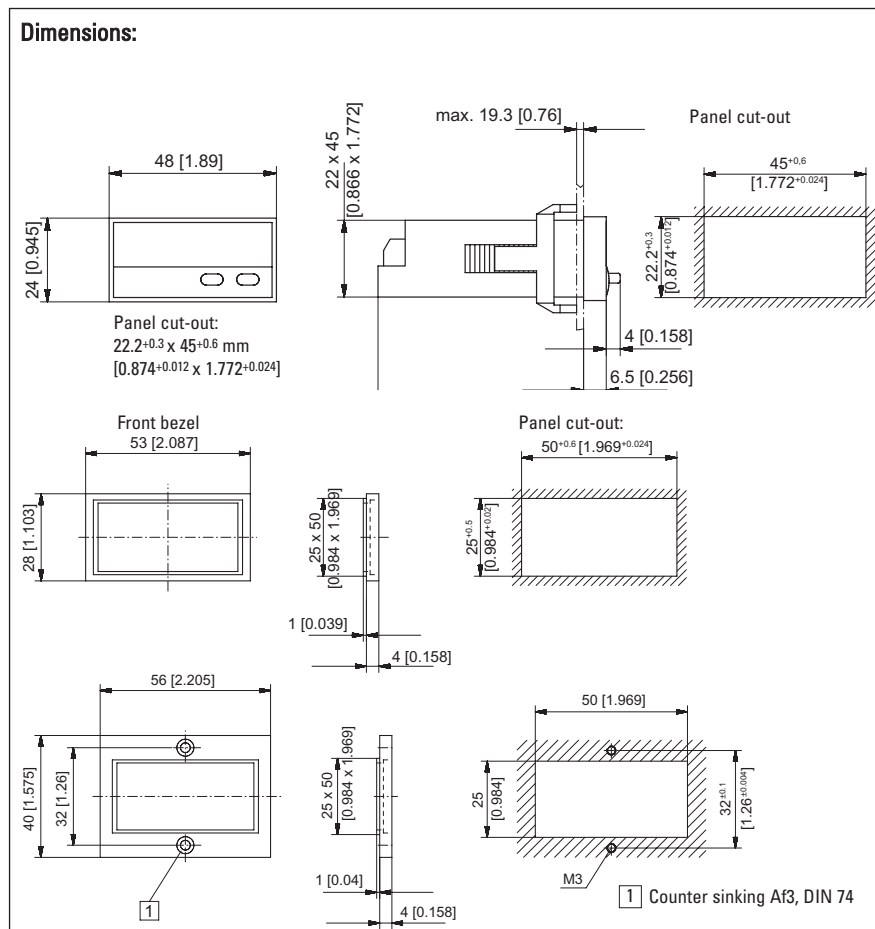

### Connections:

without optocoupler

- 1 10 ... 30 V DC
- 2 0 V GND
- 3 INP A
- 4 INP B
- 5 Reset

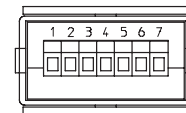
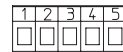

### Delivery specifications:

- 1 Digital display
- 1 Panel mounting clip
- 1 Bezel for screw mounting, panel cut out 50 x 25 mm [ 1.969 x 0.984"]
- 1 Bezel for clip mounting, panel cut out 50 x 25 mm [1.969 x 0.984"]
- 1 Seal
- 1 Multilingual operating instructions

### Order code:

6.52P.012.3X0

Input switch level

0 = Standard\*

A = 5 V

\* standard stock model

## Position indicator or totaliser **CODIX 541**

### 4 count modes:

- Count with direction
- Count difference
- Count sum of 2 inputs
- Phase discriminator (quadrature) x1, x2 and x4

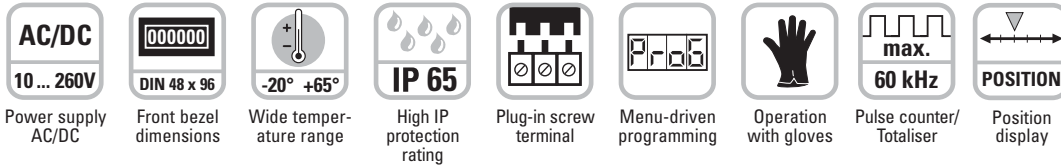

### Powerful

- **Fast count input**  
Input frequency max. 60 kHz
- **Robust housing**  
IP 65 protection
- **LED display**  
Very bright, 14 mm high
- **Position, difference, adding or detection of count direction**  
Programmable for positive (PNP) or negative (NPN) switching input pulses  
Fast count input with an input frequency of max. 60 kHz, can be damped to 30 Hz for mechanical contacts
- **Fast start-up time**  
Detects incoming pulses just 16 ms after being switched on – so no pulses are lost with a simultaneous motor start-up



### User-friendly

- **Big keys**  
Can also be operated when using gloves
- **Easy to programme**  
Easy menu-driven programming and operation  
Possibility to enter the programming mode during operation, with authentication query

### Universal

- **Individually programmable scaling**  
Multiplication and division factor (0.0001 to 99.9999), to display corresponding engineering units, e.g. position in 1/10 mm and speed in RPM.
- **4 different count input modes**  
2-channel input for detecting count direction, difference or adding mode, quadrature x1, x2 or x4
- **Programmable setpoint**
- **AC or DC power supply**  
With sensor power supply
- **Inputs**  
As an alternative to the HTL inputs, devices with a 5 VDC input trigger level are available, for use as parallel displays for PLCs.
- **Optional output**  
As zero signal

## Applications for Position Displays and Totalisers

- Positioning tasks on processing machines, such as sawing machines, milling machines, bending and folding machines, etc.
- Production data acquisition by means of piece counting (using difference or adding)
- Totalizing flow, quantity and other scaleable media
- Counting tasks such as quantity and piece counting
- Accessories, OEM equipment or retrofitting to production machines
- Piece counting on die cutters, presses, extruders, woodworking machines, drilling machines, pick-and-place machines, guillotines, special-purpose vehicles etc.

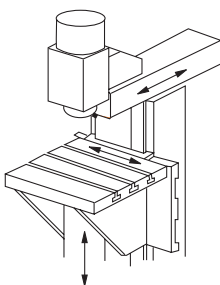

Position on milling machine

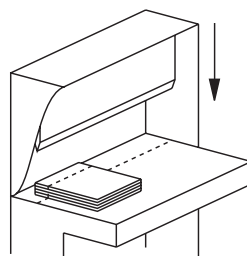

Position or quantity

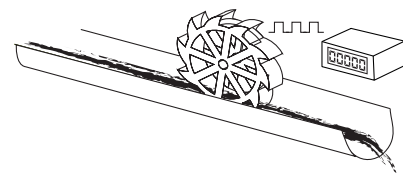

Flow rate

## Position indicator or totaliser **CODIX 541**

### Technical data:

Supply voltage:	10 ... 30 V DC, with reverse polarity protection 90 ... 260 V AC
Current consumption:	max. 50 mA, 6 VA
Display:	6-digit 7-segment red LED display; 14 mm [0.551"] high
Data backup:	EEPROM
Housing:	dimension 96 x 48 mm [3.78 x 1.89"] according to DIN 43 700; RAL 7021, grey
Polarity of Inputs:	programmable, npn or pnp for all inputs
Input resistance:	approx. 5 k $\Omega$
Counting frequency*:	max. 60 kHz, can be damped to 30 Hz, depending on operating mode at position display max. 25 kHz
Reset time:	5 ms
Input switching level (standard version):	DC-version Low: 0 ... 0.2 x U <sub>B</sub> [V DC] High: 0.6 x U <sub>B</sub> ... 30 V DC

AC-version	Low 0 ... 4 V DC High 12 ... 30 V DC
Input switching level (5 V version):	Low 0 ... 2 V DC High 4 ... 30 V DC
Voltage supply for sensors:	24 V DC $\pm$ 15 %/100 mA for AC version
Max power consumption	max. 30 V, 10 mA
Optocouplers:	
Ambient temperature:	-20 ... +65 °C [-4 ... 149 °F] non-condensing
Storage temperature:	-25 ... +70 °C [-13 ... 158 °F]
EMC:	according to EC EMC directive 89/36/EWG
Emitted interference:	EN 61000-6-4/EN 55011 class B
Immunity to interference:	EN 61000-6-2
Protection:	IP 65 front side
Weight:	approx. 150 g [5.291 oz]

\*for further specifications please refer to the manual

### Block diagram:

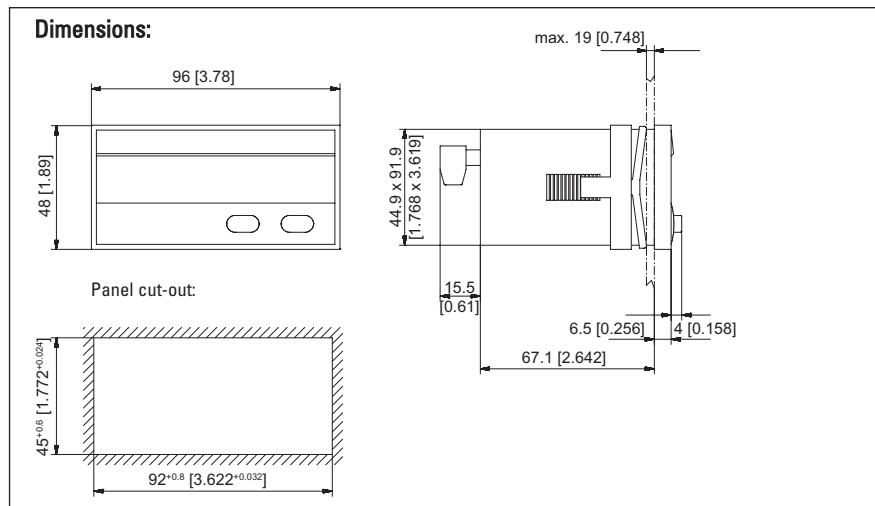
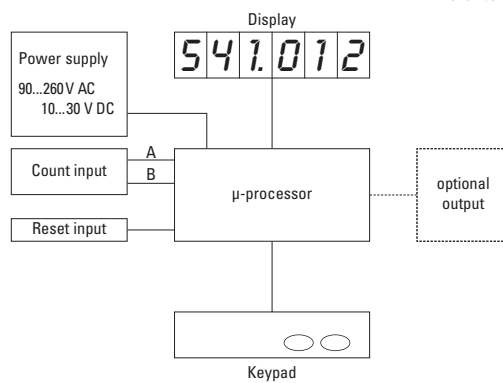

### Order code:

**6.541.01X.XX0**

Output 1 = Optocoupler output 2 = No output	Input switching level 0 = Standard level* A = 5 V level	Voltage supply 0 = 90 ... 260 V AC* 3 = 10 ... 30 V DC*
---	---	---

\* standard stock model

### Connections:

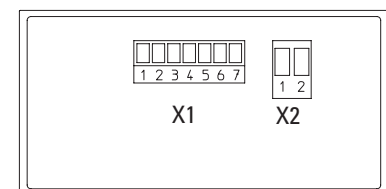

#### Connection: X2:

Pin	AC-version	DC-version
1	90 ... 260 V AC	0 V DC (GND)
2	90 ... 260 V AC	10 ... 30 V DC

#### Connection X1:

Pin	AC-version	DC-version
1	Optocoupler-output Emitter	
2	Optocoupler-output Collector	
3	Set	
4	INP B	
5	INP A	
6	GNDout	n.c.
7	+24 Vout	n.c.

**Delivery specification:** Seal  
Digital display Multilingual operating instructions  
Mounting clip

## Multifunction display *CODIX 544*

programmable as:

- Pulse counter
- Position display
- Frequency / speed display
- Timer/ short time meter



Power supply  
AC/DC



Front bezel  
dimensions

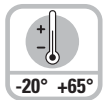

Wide temper-  
ature range



High IP  
protection  
rating



Plug-in screw  
terminal



Menu-driven  
programming

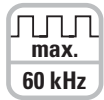

Pulse counter/  
Totaliser

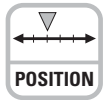

Position  
display



Frequency  
meter/  
Tachometer



Timer/  
Hour Meter



Frequency  
meter HRA

### Powerful

- **Fast count input**  
Input frequency max. 60 kHz
- **Robust housing**  
IP 65 protection
- **LED display**  
Very bright, 14 mm high
- **HRA – High Rate Accuracy System**  
Frequencies up to 38 Hz are calculated using time-interval (period duration) measurement.  
Frequencies > 38 Hz are calculated using a special time base (gate time) measurement. A very high accuracy of > 0.1% is achieved, even with very short gate times. The resulting measurement is available after a max. of 50 ms.
- **Fast start-up time**  
Detects incoming pulses just 16 ms after being switched on – so no pulses are lost with a simultaneous motor start-up



### User-friendly

- **Big keys**  
Can also be operated when using gloves
- **Easy to programme**  
Easy menu-driven programming and operation  
Possibility to enter the programming mode during operation, with authentication query

### Universal

- **Individually programmable scaling**  
Multiplication and division factor (0.0001 to 99.9999), to display corresponding engineering units, e.g. position in 1/10 mm and speed in RPM
- **4 different count input modes**  
2-channel input for detecting count direction, difference or adding mode, quadrature x1, x2 or x4
- **Frequency measurement**  
Display in 1/min or 1/sec
- **Time counting**  
Pulse width or time interval measurement in hours, minutes or seconds, as well as real-time display
- **AC or DC power supply**  
With sensor power supply
- **Inputs**  
As an alternative to the HTL inputs, devices with a 5 VDC input trigger level are available, for use as parallel displays for PLCs.
- **Optional output**  
Zero signal for position and count, zero-speed monitoring, 1 Hz clock pulse for active time measurement

### Applications for Multi-function Display

- Counting tasks such as quantity and piece counting, measuring and recording of speed and of operating and processing times
- Piece counting or tool-life measurement on die cutters, presses, extruders, wood-working machines, drilling machines,

- pick-and-place machines, guillotines, special-purpose vehicles etc.
- Positioning tasks on processing machines, such as sawing machines, milling machines, bending and folding machines, etc.

- Production data acquisition by means of piece counting (using difference or adding), or measurement of production times or production speeds.
- Totalizing flow, quantity and other scaleable media, or display of current flow rates.

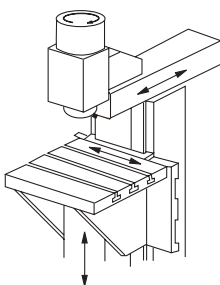

Position or rotary speed on milling machine

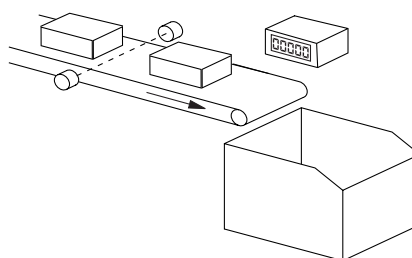

Piece count on conveyor or production speed

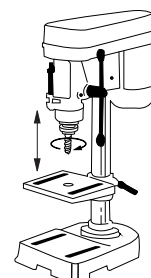

Drilling machine head, speed or drilling depth

## Multifunction display **CODIX 544**

### Technical data:

Supply voltage:	10 ... 30 V DC, with reverse polarity protection 90 ... 260 V AC
Current consumption:	max. 50 mA, 6 VA
Display:	6-digit 7-segment red LED display; 14 mm high [0.551"]
Data backup:	EEPROM
Housing:	dimension 96 x 48 mm [3.78 x 1.89"] according to DIN 43 700; RAL 7021, grey
Polarity of Inputs:	programmable, npn or pnp for all inputs
Input resistance:	approx. 5 k $\Omega$
Counting frequency*:	60 kHz, can be damped to 30 Hz depending on operating mode at position display max. 25 kHz
Reset time:	5 ms
Display range timer:	0.001 s ... 999999 h
Input switching level (standard version):	DC-version Low: 0 ... 0.2 [0 ... 0.008"] x U <sub>B</sub> [V DC] High: 0.6 x [0.024"] U <sub>B</sub> ... 30 V DC

	AC-version
	Low 0 ... 4 V DC
	High 12 ... 30 V DC
Input switching level (5 V version):	Low: 0 ... 2 V DC High: 4 ... 30 V DC
Voltage supply for sensors:	24 V DC $\pm$ 15 %/100 mA at AC-versions
Accuracy:	Tachometer: <0,1 % Timer < 50 ppm
Ambient temperature:	-20 ... +65 °C [-4 ... 149 °F]
Storage temperature:	-25 ... +70 °C [-13 ... 158 °F]
EMC:	according to EC EMC directive 89/36/EWG
Emitted interference:	EN 61000-6-4/EN 55011 class B
Immunity to interference:	EN 61000-6-2
Protection:	IP65 from front
Weight:	approx. 150 g [5.291 oz]

\*for further specifications please refer to the manual

### Block diagram:

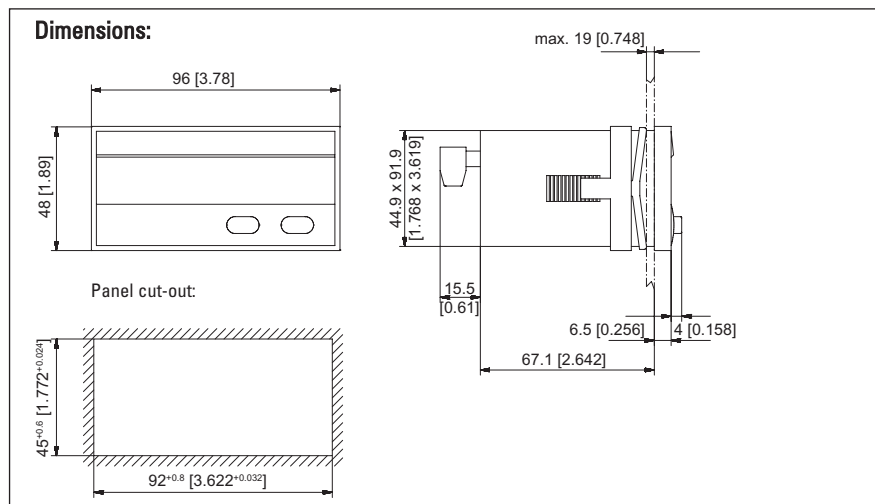
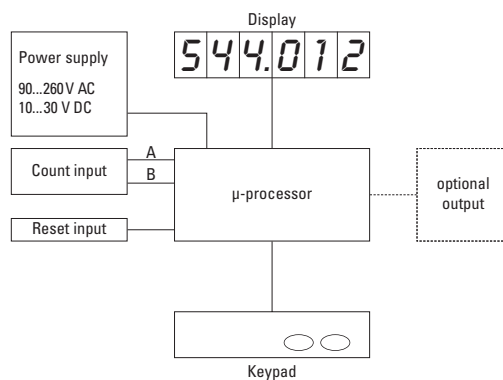

### Order code:

**6.544.01X.XX0**

Output 1 = Optocoupler output* 2 = No output	Input switching level 0 = Standard level* A = 5 V level	Voltage supply 0 = 90 ... 260 V AC* 3 = 10 ... 30 V DC
--	---	--

\* standard stock model

### Connections:

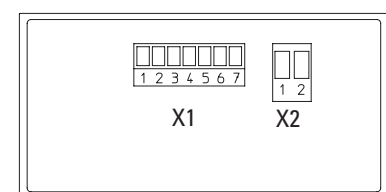

#### Connection: X2:

Pin	AC-version	DC-version
1	90 ... 260 V AC	0 V DC (GND)
2	90 ... 260 V AC	10 ... 30 V DC

#### Connection X1:

Pin	AC-version	DC-version
1	Optocoupler-output Emitter	
2	Optocoupler-output Collector	
3	Set	
4	INP B	
5	INP A	
6	GNDout	n.c.
7	+24 Vout	n.c.

<b>Delivery specification:</b>	Seal
Digital display	Multilingual operating instructions
Mounting clip	

## Position and Frequency display **CODIX 54P**

separate inputs for frequency and position

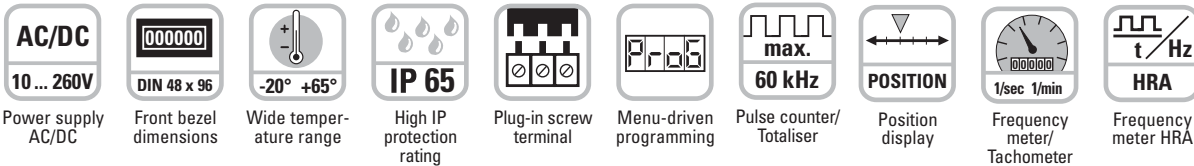

### Powerful

- **Fast count input**  
Input frequency max. 60 kHz
- **Robust housing**  
IP 65 protection
- **LED display**  
Very bright, 14 mm high
- **HRA – High Rate Accuracy System**  
Frequencies up to 38 Hz are calculated using time-interval (period duration) measurement.  
Frequencies > 38 Hz are calculated using a special time base (gate time) measurement. A very high accuracy of > 0.1% is achieved, even with very short gate times. The resulting measurement is available after a max. of 50 ms.
- **Fast start-up time**  
Detects incoming pulses just 16 ms after being switched on – so no pulses are lost with a simultaneous motor start-up



### User-friendly

- **Big keys**  
Can also be operated when using gloves
- **Easy to programme**  
Easy menu-driven programming and operation  
Possibility to enter the programming mode during operation, with authentication query  
Pressing the right key switches between displays

### Universal

- **Individually programmable scaling**  
Multiplication and division factor (0.0001 to 99.9999), to display corresponding engineering units, e.g. position in 1/10 mm and speed in RPM.
- **Separate factors and inputs for frequency- and pulse counting**
- **4 different count input modes for the position display**  
2-channel input for detecting count direction, difference or adding mode, quadrature x1, x2 or x4. 1 separate input for rotary speed and speed, display in 1/min or 1/sec
- **AC or DC power supply**  
With sensor power supply
- **Inputs**  
As an alternative to the HTL inputs, devices with a 5 VDC input trigger level are available, for use as parallel displays for PLCs

## Applications for Frequency and Position Display/ Totaliser

Position and rotary speed applications, e.g.

- OEM equipment or retrofitting to drilling machines
- OEM equipment on flow measuring plant, e.g. total flow and current flow
- Total piece count and pieces per minute, where the pulse counting occurs in the add/subtract mode, in order to deduct reject parts
- Production data acquisition: total piece count and production speed, or absolute distance traversed and current speed

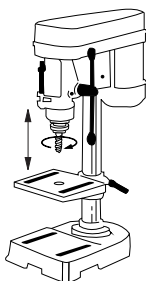

Rotary speed and drilling depth

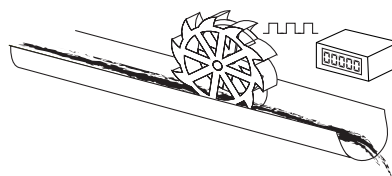

Flow rate and total volume

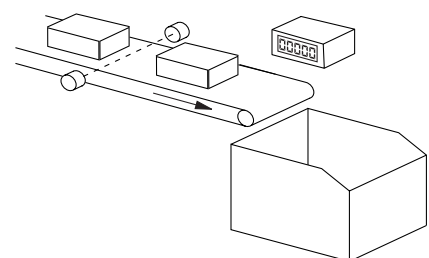

Piece count on conveyor and production speed

## Position and Frequency display **CODIX 54P**

### Technical data:

Supply voltage:	10 ... 30 V DC, with reverse polarity protection 90 ... 260 V AC
Current consumption:	max. 50 mA, 6 VA
Display:	6-digit 7-segment red LED display; 14 mm [0.551"] high
Data backup:	EEPROM
Housing:	Dimension 96 x 48 mm [3.78 x 1.89"] according to DIN 43 700; RAL 7021, grey
Polarity of Inputs:	programmable, npn or pnp for all inputs
Input resistance:	approx. 5 kΩ
Counting frequency*:	30 kHz, can be damped to 30 Hz depending on operating mode
Reset time:	5 ms
Input switching level (standard version):	DC-version: Low: 0 ... 0.2 [0 ... 0.008"] x U <sub>B</sub> [V DC] High: 0.6 [0.024"] x U <sub>B</sub> ... 30 V DC

AC-version:	Low 0 ... 4 V DC High 12 ... 30 V DC
Input switching level (5 V version):	Low 0 ... 2 V DC High 4 ... 30 V DC
Accuracy:	<0.1 % (Frequency display/Rate meter)
Voltage supply for sensors:	24 V DC ±15 %/100 mA at AC version
Ambient temperature:	-20 ... +65 °C [-4 ... 149 °F] non-condensing
Storage temperature:	-25 ... +70 °C [-13 ... 158 °F]
EMC:	according to EC EMC directive 89/36/EWG
Emitted interference:	EN 61000-6-4/EN 55011 class B
Immunity to interference:	EN 61000-6-2
Protection:	IP65 from front
Weight:	approx. 150 g [5.291 oz]

### Block diagram:

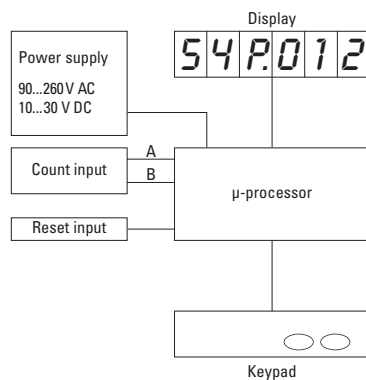

\*for further specifications please refer to the manual

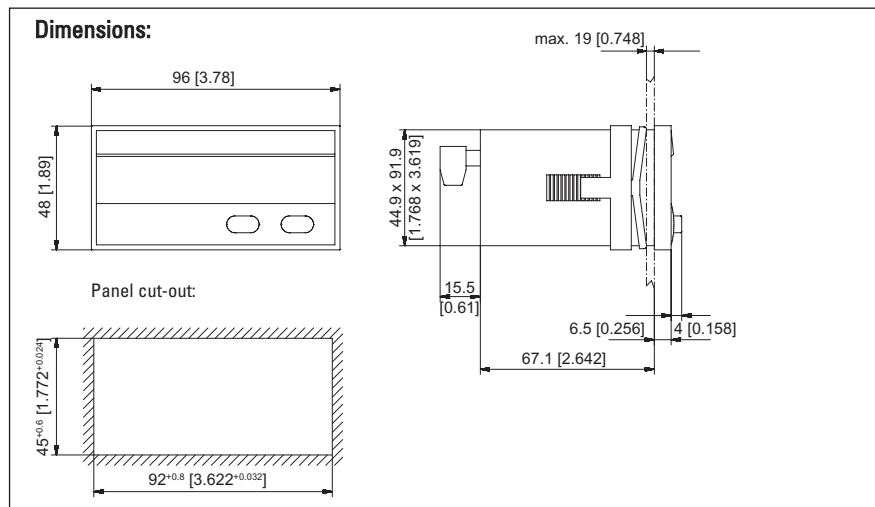

### Order code:

**6.54P.012.XX0**

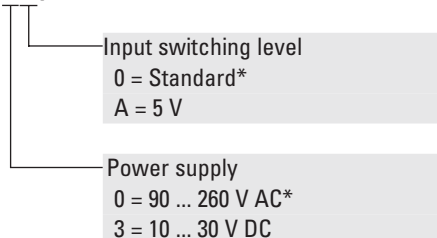

\* standard stock model

### Connections:

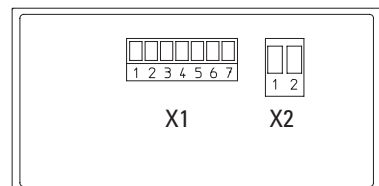

#### Connection: X2

Pin	AC-version	DC-version
1	90 ... 260 V AC	0 V DC (GND)
2	90 ... 260 V AC	10 ... 30 V DC

#### Connection: X1

Pin	AC-Version	DC-Version
1	n.c.	
2	n.c.	
3	INP C (Frequency)	
4	INP B (Count)	
5	INP A (Count)	
6	GNDout	n.c.
7	+24 Vout	n.c.

### Delivery specification:

- Digital display
- Mounting clip
- Seal
- Multilingual operating instructions

## Universal Preset Counter *CODIX* 923 / 924

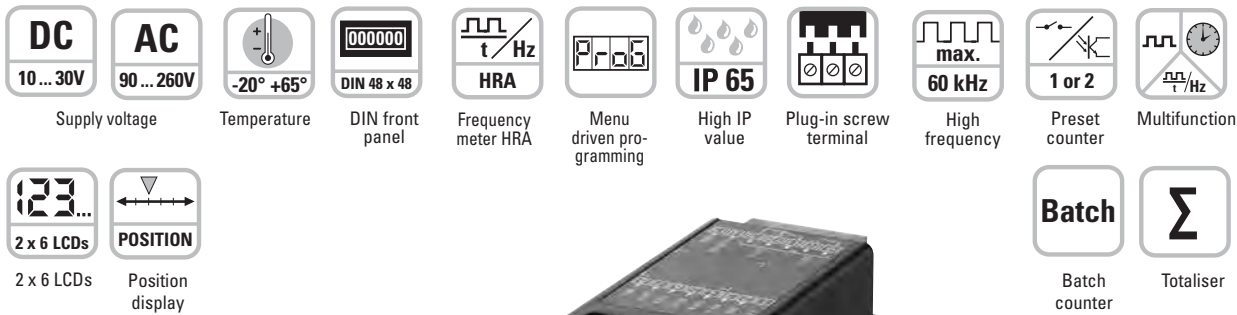

### Multifunction:

- Counter, Tachometer and Timer – all in one device
- Can be used as preset counter, batch counter or totaliser (overall cumulative count)
- 1 or 2 presets (additional presets on request)
- Relay or optocoupler outputs
- Wide choice of count modes for pulse inputs, time or frequency
- Averaging, start delay (Tachometer)
- Scalable display with multiplikation and division factor, set value
- Step or tracking presets

### Fast:

- Direct input of the presets via the front keys or the Teach-In input
- Fast installation thanks to plug-in screw terminals and integrated sealing gaskets
- Max. count frequency 60 kHz

### User-friendly:

- Simultaneous display of the actual value, presets, batch count or total count
- Annunciators for the displayed preset and for the output status
- 3 predefined settings for the most common parameter settings
- Direct entry into the programming
- Tracking presets eliminate the need for reprogramming of the pre-signal
- Minimum installation depth
- 4 stage RESET modes
- 3 stage key lockout

### Technical data:

Supply voltage:	90 ... 260 V AC/max. 8 VA, 50/60 HZ, External fuse protection T 0.1 A 10 ... 30 V DC/max. 1.5 W External fuse protection T 0.2 A
Display:	2-line 6-digits LCD display LCD pos. (green) backlighting
Count inputs:	
Polarity of the inputs:	programmable for all inputs in common NPN/PNP
Input resistance:	5 k $\Omega$
Count frequency:	max. 55 kHz (details see manual)
Min pulse duration of the inputs:	10 ms / 1 ms
Switching levels with AC-supply:	
HTL-level	Low: 0 ... 4 V DC High: 12 ... 30 V DC
5 V-level	Low: 0 ... 2 V DC High: 3.5 ... 30 V DC
Switching level with DC-supply:	
HTL-level	Low: 0 ... 0.2 x U <sub>B</sub> High: 0.6 x U <sub>B</sub> ... 30 V DC
5 V-level	Low: 0 ... 2 V DC High: 3.5 ... 30 V DC
Pulse shape:	variable, Schmitt-Trigger characteristics
Output	Switching voltage max. 250 V AC/110 V DC Switching current max. 3 A AC/A DC

Output 1	Switching current min. 30 mA DC Switching capacity max. 750 VA/90 W Mech. service life (switching cycles) 2 x 10 <sup>7</sup> N° of switching cycles at 3 A/250 V AC 1 x 10 <sup>5</sup> N° of switching cycles at 3 A/30 V DC 1 x 10 <sup>5</sup> Relay closing contact, programmable as normally open (NO) or normally closed (NC)
Output 2	Mech. service life (switching cycles) 20 x 10 <sup>6</sup> N° of switching cycles at 3 A/250 V AC 5 x 10 <sup>4</sup> N° of switching cycles at 3 A/30 V DC 5 x 10 <sup>4</sup> Relay with changeover contact
or npn optocoupler:	switching power 30 V DC/10 mA U <sub>CESAT</sub> at IC = 10 mA: max. 2.0 V U <sub>CESAT</sub> at IC = 5 mA: max. 0.4 V
Reaction time of the outputs:	Relay: approx 7 ms Optocoupler: approx 1 ms, Details see instruction manual
Response time of the frequency counter:	100/600 ms, Details see instruction manual
Data retention:	min. 10 years, EEPROM
Count modes:	
Pulse counter:	cnt.dir, up.dn, up.up, quad, quad 2, quad4, A/B, (A-B)/A x 100%
Frequency counter:	A, A-B, A+B, quad, A/B, (A-B)/A x 100%
Timer:	FrErun, Auto, InpA.InpB., InpB.InpB.



## Technical Data:

Voltage supply for sensors:	
AC supply	24 V DC ± 15%, 80 mA
DC supply	max. 80 mA, external voltage supply is connected through
Operating temperature:	-20 °C ... +65 °C
Storage temperature:	-25 °C ... +75 °C

Humidity:	RH 93% at +40 °C, non-condensing
EMC:	CE compliant to EU directive 89/36/EWG
Standards:	EN 61 000-6-4/EN 55011 class B EN 61000-6-2
UL (applied for):	File-N°.: E128604
Protection:	IP65 (front)
Weight:	approx. 125 g

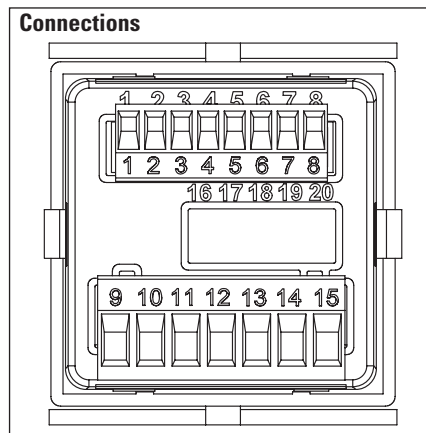
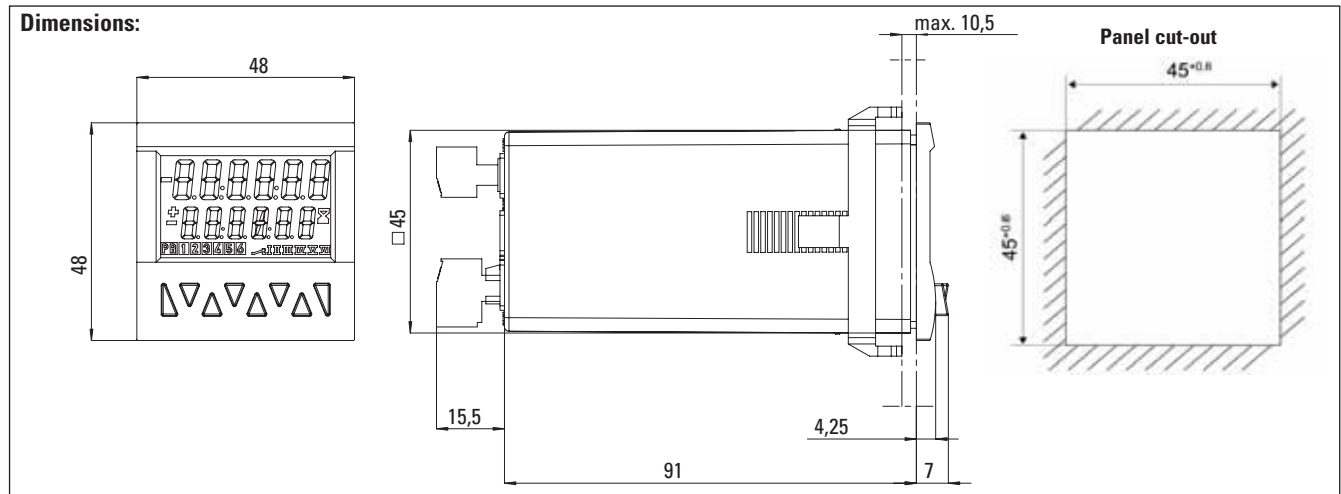

### Signal and control inputs

- 1 Sensor voltage supply  
AC: 24 VDC/80 mA  
DC: UB interconnected
- 2 GND (0 VDC)
- 3 INP A (Signal input A)
- 4 INP B (Signal input B)
- 5 RESET (Reset input)
- 6 LOCK (Key locking input)
- 7 GATE (Gate input)
- 8 MPI (User input)
- 16 ... 20:  
Additional optional inputs or outputs or interfaces

### Version with relays/optocouplers

- |                                    |                  |
|------------------------------------|------------------|
| 9 Relay contact C./Collector       | } Output 1       |
| 10 Relay contact N.O./Emitter      |                  |
| 11 Relay contact C./Emitter        | } Output 2       |
| 12 Relay contact N.O./not assigned |                  |
| 13 Relay contact N.C./ Collector   | } Supply voltage |
| 14 AC: 90..260 VAC N~              |                  |
| DC: 10..30 VDC                     |                  |
| 15 AC: 90..260 VAC L~              |                  |
| DC: GND (0 VDC)                    |                  |

### Delivery specification:

- Preset counter
- Mounting clip
- Operating instructions

## 6.92X.01XX.XX0

### Order code:

Number of presets  
3 = 1 preset  
4 = 2 preset

Outputs  
0 = Relays  
1 = Optocouplers (only 924)

LCD options  
0 = no backlighting  
1 = green backlighting

Input trigger level  
0 = Standard level (HTL)  
A = 5 V-level

Supply voltage  
0 = 90–260 V/AC  
3 = 10–30 V/DC

Options: Additional inputs or outputs or interfaces on request

### Standard stock models:

6.923.0100.000 6.924.0100.000  
6.923.0100.300 6.924.0100.300

## Areas of application for 923/924:

### ■ Pulse counter

#### Functions/ Count modes

- Count with direction mode
- Difference mode
- Quadrature mode quad/quad2/quad4
- Add, Sub, automatic reset
- 2-input adding mode A+B
- Ratio measurement A/B
- Percentage difference measurement  $(A-B)/A \times 100\%$
- Batch counting
- Totaliser (Overall total)
- Multiplication and division factor (up to 99.999)
- Set value
- Step or tracking preset

#### Application examples

##### CountDir

Roller shutter door with automatic shutoff

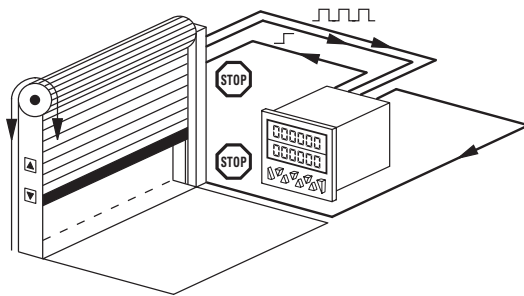

##### Quad

Running direction and position on milling machines

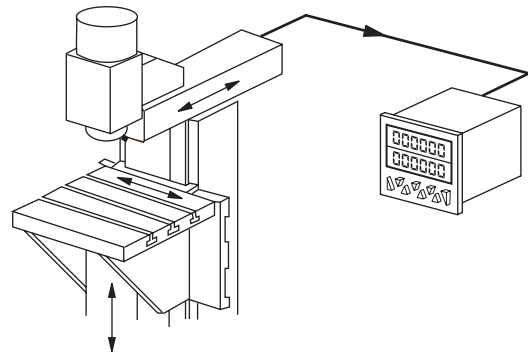

##### UpDown

Automatic subtraction of faulty or reject parts from the total piece count

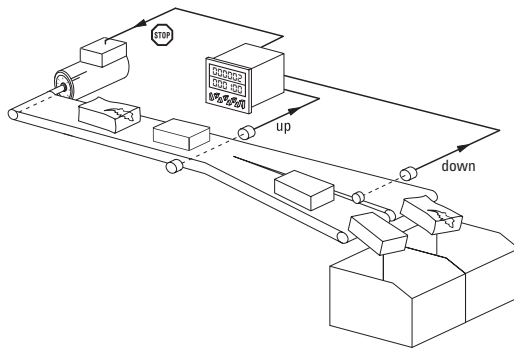

##### Batch

Logging of piece numbers and packing units plus control of replenishment of packing cartons

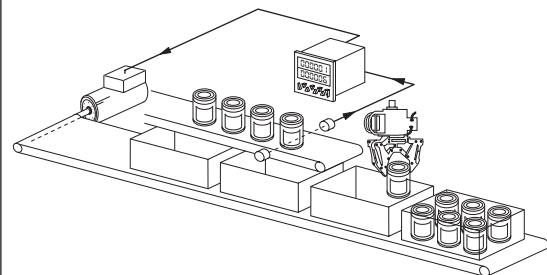

##### UpUp

Adding up of two parallel or staggered production lines

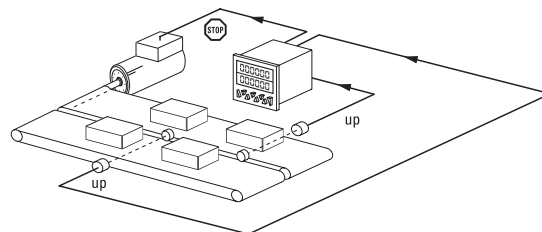

##### Add tot

Cut-to-length with overall total count

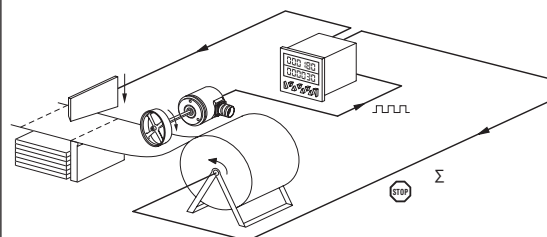

## Areas of application for 923/924:

### ■ Frequency counter (Tachometer)

#### Functions/ Count modes

- A
  - B
  - A - B
  - A + B
  - A / B
  - (A - B) / A x 100 % (percentage display)
- Quad (Phase discriminator with recognition of direction)
  - Averaging
  - Start delay
  - 2nd tacho input
  - Gate input
  - Multiplication and division factor (up to 99.9999)

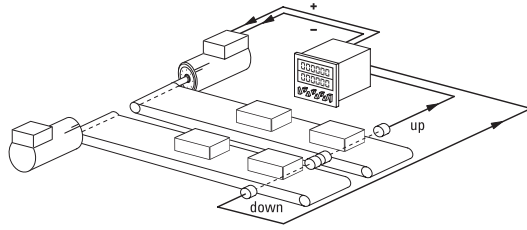
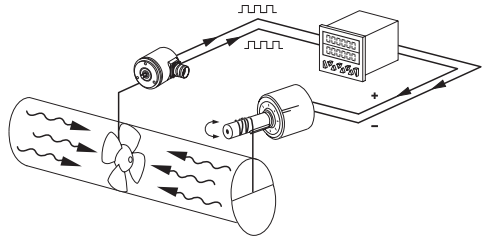
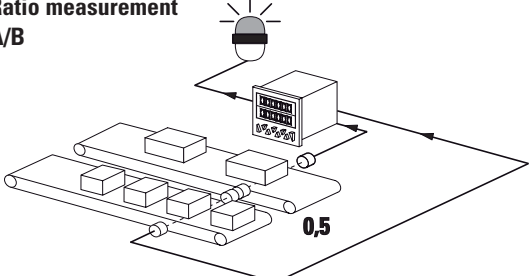
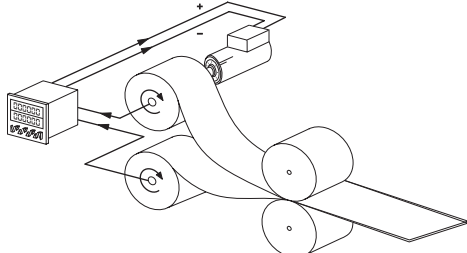
<b>Application examples</b>	<b>A - B</b> Synchro monitoring and control of two conveyor belts 	<b>Speed regulation with indication of direction</b> 
	<b>Ratio measurement A/B</b> 	<b>Ratio measurement e.g. for speed alignment</b> 

### ■ Time and hours-run meter (Timer)

#### Functions/ Count modes

- FrErUn (Control via gate input)
  - Auto (Start via Reset, Stop at preset)
  - InpB.InpB (Start with first edge at InpB., Stop with second edge InpB.)
  - InpA. InpB (Start with InpA., Stop with InpB.)
- Totaliser (Overall total)
  - Batch counting
  - Set value
  - Step or tracking preset

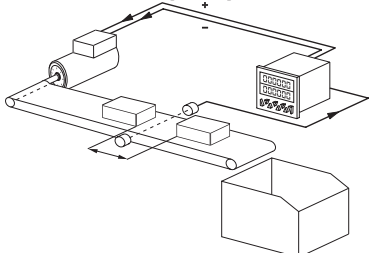
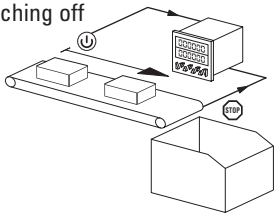
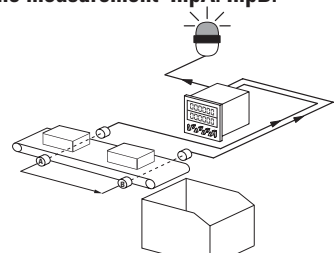
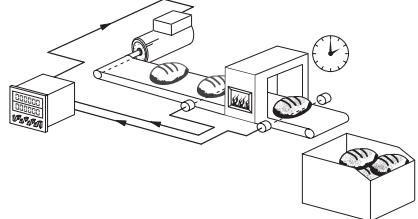
<b>Application examples</b>	<b>Interval measurement InpB. InpB</b> 	<b>FrErUn</b> Measurement of overall time from switching on the conveyor belt till switching off 
	<b>Run-time measurement InpA. InpB.</b> 	<b>Auto time-controlled production line</b> 

## Universal Preset Counter **CODIX 923/924**

Your control solution, ready-to-go · very easy to operate ·  
direct display · expandable via module individual functionality.



### Multifunction

More than just preset counters: the **CODIX 923/924** are multi-talented and can handle the display, measurement and control of pulses (counter), frequencies (tacho) and time (timer) using numerous count functions and modes.

**Open to many applications.** The great advantage of the **CODIX 923/924** preset counters: they offer a simple and cost-effective solution for many local standard control functions. It is not necessary to have in-depth programming knowledge when installing or using the product, which does away with the need for costly service engineers.

### Expandable

Numerous logic functions and preconfigured, selectable operating modes for a variety of applications, including for example positioning and batch counting, make the counter a real alternative to a PLC – and with the benefit of a display included.

The devices are so designed that they are expandable for OEM applications. Both hardware and software can be modified and expanded. PCB-board receptacles are provided in the counter for hardware upgrade purposes:

- Up to 10 inputs
- Up to 6 optocoupler outputs
- Up to 4 relay outputs
- Interface RS 232/485
- Individual functions

The software can be specifically customised to OEM applications. This includes the logic behaviour of the inputs and outputs (I/O functionality) or the whole display unit.

Expandable on request via modules:

- 4 additional inputs
- or 4 additional optocoupler outputs
- or 2 additional relay outputs
- or RS 232/485 interfaces

Application examples:

- Limit switch monitoring
- Special functions/PLC function
- Initiation of fixed program sequences
- Control of several processes
- Special protocols
- Print commands for logging

Individual customisation of software to your application.

For example:

- Separate inputs for total counter and preset counter
- Separate scaling of input A and B
- Programmable measuring period for the tachometer
- Measurement of rotary speeds based on time
- Processing time, measurement of time based on frequency

#### Expandable hardware:



#### Customisable software:



#### With your logo:



Free-of-charge for 100+ pcs.

Typically a simple OEM customisation is worthwhile for annual quantities of 20-50 pcs. We would be happy to solve this task for you quickly, professionally and economically.  
Phone +49 (0) 77 20 - 39 03-38  
or info@kuebler.com

## Universal Preset Counter **CODIX 923 / 924**

### User-friendly



*Fresh, modern design that further enhances your panel or equipment.*

**Simple filing-cabinet programming structure** for fast entry of parameters. Quickly operational: after each parameter has been modified, it is possible to exit the programming by means of the reset key.

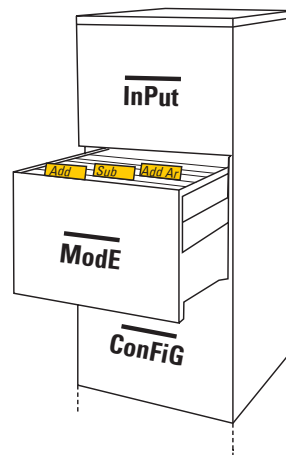

**Convenient time-saving installation:** Plug-in screw terminal connections with cage clamp terminals. IP 65 sealed front bezel as standard. Saves additional time & effort for protection when installing. Minimal installation depth – will fit anywhere



**Comprehensive, large display:** 2-line, 2 x 6-digit LCD display with sign, leading zero suppression, giving a display range from -999 999 to +999 999. Optional backlighting for good readability in all situations.

**Easy-to-operate** without programming knowledge. Direct access to the programming mode for all count functions. User-friendly, thanks to the simplified programming structure and alpha-numeric display of the parameters.



**Easy-to-understand:** thanks to the use of annunciators for the displayed preset and the status of both outputs, as well as the simultaneous display of the actual value and the presets or the auxiliary counters.



**New: MPI input** (multiple purpose input) with the functions: Display Hold, Set and Teach-In.



**Three predefined settings:** with parameter settings for the most common applications.

**The compact decade key-pad:** allows for a large display and enables simple direct entry of the presets.

**Preset via Teach-In input:** for simple error-free entry of the preset. A reset key plus programming mode key are already integrated.



## Display Type 571



### Your benefit

- AC and DC supply voltage in one unit
- Measuring function can be programmed for RPM, speed (from elapsed time), machine cycle time, throughput and baking time (time interval), as well as numerous count and stop-watch functions
- Scaleable display, programmed via 2 keys
- Large 15 mm [0.591"] high LED-display, 6-digit, with adjustable brightness

### Product features

- Fast count input, works with our **LIMES** measuring system (100kHz)
- Version with 2 optocoupler outputs for alarms
- Version with analogue output, resolution 14 Bit: 0 ... 10 V, +10 V ... -10 V, 0 ... 20 mA, 4 ... 20 mA
- Version with serial interface RS232/485 for importing and exporting data
- 48 x 96 mm [1.89 x 3.78"] DIN housing, IP 65

### Technical data:

Supply voltage:	16 ... 35 V DC (Normal voltage: 24 V DC) 115/230 V AC $\pm$ 12,5 %
Display:	15 mm [0.591"] high LED-display, 6 digits
Current consumption [DC]:	18 V: 120 mA; 24 V: 95 mA; 30 V: 80 mA
Power consumption [AC]:	7.5 VA
Sensor power supply:	24 V DC $\pm$ 15%, 120 mA (at AC and DC supply)
<b>Inputs:</b>	3 Inputs (PNP, NPN and Namur) A, B = Impulse, C = Reset
Max. input frequency:	A, B = 25 kHz (100 kHz at count); C = 1 kHz
(Accuracy:	$\pm$ 1 ppm $\pm$ 1 digit
Input level HTL:	Low: 0 ... 3,5 V High: 9 ... 35 V

<b>Outputs:</b>	
Analogue-Output: (0.571.012.E90)	0 ... +10 V, 0 ... -10 V and 0 ... 20 mA, 4 ... 20mA
Resolution:	14 Bit + Sign
Accuracy:	0,1 %
Optocoupler-Output: (0.571.011.E00)	5 ... 35 V DC/150 mA
Interface (0.571.012.E05)	RS232 and RS485 acc. to ISO 1745 Drivecom Protocol
Operating temperature:	0 ... +45 °C [32 °F ... 113 °F]
Storage temperature:	-25 ... +70 °C [-13 °F ... 158 °F]
Protection:	IP 65 front side
EMC:	according to EC EMC directive 89/36/EWG
Interference emission:	EN 50081-2/EN 55011 class B
Interference resistance:	EN 6100-6-2
Weight:	approx. 200 g [7.055 oz]

### Dimensions:

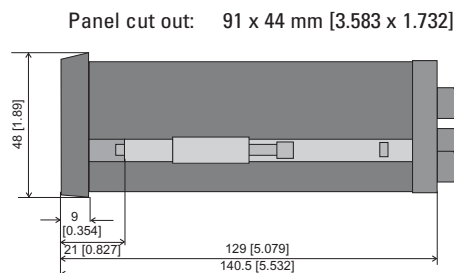
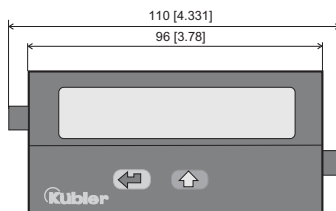

Display with serial interface (0.571.012.E05)

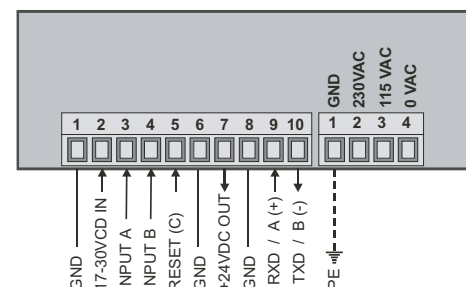

### Terminal assignment:

Display with analogue output (0.571.012.E90)

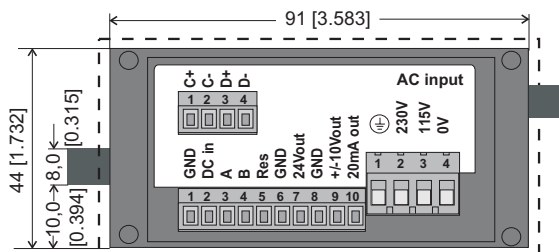

Display with 2 optocoupler outputs (0.571.011.E00)

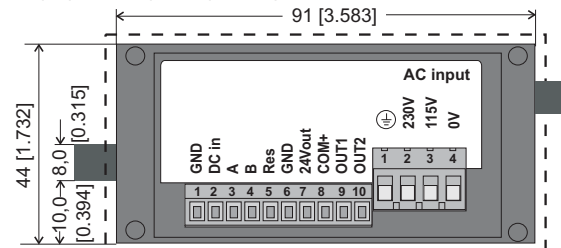

### Delivery specifications:

- Display 571
- Seal
- Mounting kit
- Plug-in screw terminals
- Manual German/English

### Order data:

- Display with 2 outputs Order code: 0.571.011.E00\*
- Display with analogue output Order code: 0.571.012.E90\*
- Display with ser. interface Order code: 0.571.012.E05

\* standard stock model

## SSI-Display Type 570



### Your benefit

- AC and DC supply voltage in one unit
- Master- or slave mode
- Plug-in screw terminals
- SSI-clock frequency from 100 Hz up to 1 MHz
- Display and outputs may be adjusted using scaling- and offset-features
- Large 15 mm [0.591"] high LED-display, 6-digit, with adjustable brightness

### Product features

- Qualified for SSI-protocols up to 25 Bit
- Version with 2 optocoupler outputs to work as limit or preset values; also with programmable tracking preset.
- Version with scaleable analogue output, resolution 14 Bit, 0 ... 10 V, -10 ... +10 V, 0 ... 20 mA or 4 ... 20mA
- Grey- or binary-code
- 48 x 96mm [1.89 x 3.78"] DIN-housing, IP 65

### Technical data:

Supply voltage:	17 ... 30 V DC
Display:	15 mm [0.591"] high LED-display, 6 digits
Current consumption [DC]:	17 V: 190 mA; 24 V: 150 mA; 30 V: 120 mA
Power consumption [AC]:	7.5 VA
Sensor power supply:	24 V DC ± 15%, 120 mA
<b>Inputs:</b>	
SSI-input frequency range:	100 Hz ... 1 MHz
Input reset:	PNP or NPN, programmable 5.1 mA 24 V DC/ R <sub>i</sub> = 4.7 kOhm
Input level:	Low: 0 ... 2 V High: 9 ... 35 V
Reset time:	min. 5 ms

<b>Outputs:</b>	
Scaleable analogue output (0.570.012.E90):	0 ... 10 V, -10 ... +10 V or 0 ... 20 mA, 4 ... 20mA
Resolution:	14 Bit + Sign
Accuracy:	0.1 %
Optocoupler output: (0.570.012.E05)	5 ... 35 V DC/150 mA
Interface:	RS232 and RS 485 to ISO 1745 Drivecom Protocol
Operating temperature:	0 ... +45 °C [32 ... 113 °F]
Storage temperature:	-25 ... +70 °C [-13 ... 158 °F]
Protection class:	IP 65 front side
EMC:	according to EC EMC directive 89/36/EWG
Interference emission:	EN 6100-6-3/EN 55011 class B
Interference resistance:	EN 6100-6-2
Weight:	approx. 200 g [7.055 oz]

### Dimensions:

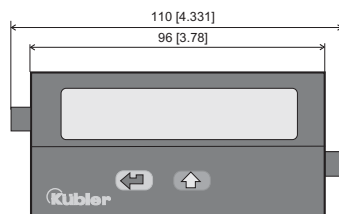

Panel cut-out: 92 x 45 mm [3.622 x 1.772]

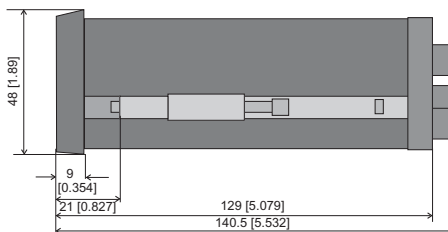

Display with serial interface (0.570.012.E05)

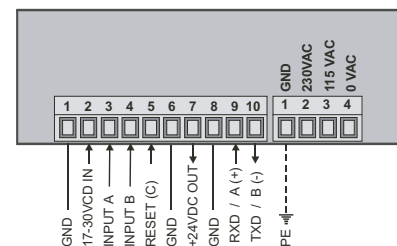

### Wiring diagram:

Display with analogue output (0.570.012.E90)

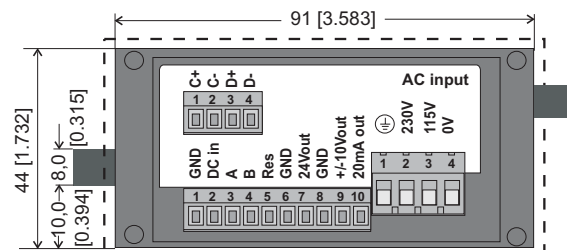

Display with 2 optocoupler outputs (0.570.011.E00)

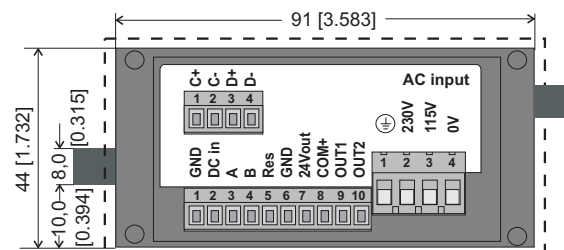

Do not connect A, B; C+, C- = clock signal SSI; D+, D- = data signal SSI

### Delivery specifications:









- SSI-Display
- Seal
- Mounting kit
- Plug-in screw terminals
- Manual German/English

### Order code:

- Display with 2 outputs: 0.570.011.E00\*
- Display with analogue output: 0.570.012.E90\*
- Display with ser. interface: 0.570.012.E05





\* standard stock model

## Overview

1. Accessories for counters with panel cut out 22,2 x 45, 25 x 50 or 29 x 552.1				
1.1 Front bezels	Accessories	for counter types	Remarks	Page
	Bezel adapter 37.1 for cut-out 25 x 50 mm [0.984 x 1.969"] with screw fixing	W15.5, W16.5, W17.5 <b>CODIX</b> 13x, <b>CODIX</b> 52x, H37	available in black, grey and anthracite	294
	Slip on bezel 37.2, for panel cut-out 25 x 50 mm [0.984 x 1.969"]	W15.5, W16.5, W17.5 <b>CODIX</b> 13x, <b>CODIX</b> 52x, H37	available in black and tin anodized, as set	294
	Bezel adapter for cut-out 68 x 33 mm [2.678 x 1.299"]	W15.5, W16.5, W17.5 <b>CODIX</b> 13x, <b>CODIX</b> 52x, H37	available in black, grey tin anodized as set	294
	Bezel adapter 50 x 60 mm [1.969 x 2.363"] for 18 x counter for screw fixing with sealing gaskets	184, 185, 186, 187 <b>CODIX</b> 13x	available in black	294
	Bezel adapter 50 x 60 mm [1.969 x 2.363"] for panel cut-out 29 x 55 mm [1.142 x 2.166"] for screw fixing with sealing gaskets	52X, 13X, H37, W15.5, W16.5, W17.5	available in black	295
	Bezel adapter 24 x 48 mm [0.945 x 1.89"] for panel cut-out 48 x 48 mm [1.89 x 1.89"] for screw fixing with sealing gaskets	52X, 13X, H37, W15.5, W16.5, W17.5	available in black	295
	Front bezel for cut-out 29 x 55 mm [1.142 x 2.166"] Size F1	B/HB counter	available in black and beige; plug in from front	295
1.2 Socket boxes	Accessories	for counter type	remarks	Page
	Socket box 945.2	B/HB counter	plug in from front	296



## Overview

1.3 Sealing covers	Accessories	for counter types	Remarks	Page
	Flexible sealing cover type K1 for size F1, IP 65	B, HB or 29 x 48 mm [1.142 x 1.89"] counter in adapter bezel 50 x 60 mm [1.969 x 2.363"]		296
	Sealing covers 1 Dv for size F1, IP 65, with front bezel	B, HB or 29 x 48 mm [1.142 x 1.89"] counter with adapter bezel 50 x 60 mm [1.969 x 2.363"]	lockable front bezel, screw-on with gasket, using M4 fixing screws	296
	Transparent cover 1 Dv for size F1, IP 65 with key lock	B, HB with front bezel 50 x 60 mm [1.969 x 2.363"]	Front bezel with key lock, with 2 gaskets, can be screwed on to counter bezel	296
	Transparent cover 1 Dvs for size F1, IP 65, with key-lock	B, HB with front bezel 50 x 60 mm [1.969 x 2.363"]	Front bezel with key lock, with 2 gaskets can be screwed on to counter bezel, supplied with two keys	296







## 2. Software





- Easy parameter software for counter types 716/717 and process displays and controllers 55x.







see page 293

## Overview









3. Accessories for counters with cut-out 45 x 45, 50 x 50 or 54 x 54				
3.1 Front panel	Accessories	for counter type	Remarks	Page
	Bezel adapter 55 for cut-out 50 x 50 mm [1.969 x 1.969"] to 45 x 45 mm [1.772 x 1.772"]	H57 and HC77	black	297
	Bezel adapter 55 for el. counter 45 x 45 mm [1.772 x 1.772"] for cut-out 50 x 50 mm [1.969 x 1.969"]	901, 903, 904, 923, 924, 715 <b>CODIX</b> 716/717, 910	anthracite	298
	Adapter 75 x 60 mm [2.953 x 2.363"] for cut-out 50 x 50 mm [1.969 x 1.969"] to 45 x 45 mm [1.772 x 1.772"] for screw fixing	901, 903, 904, 923, 924, 715 <b>CODIX</b> 716/717, 910		298
	Bezel adapter 68 x 68 mm [2.678 x 2.678"] to 45 x 45 mm [1.772 x 1.772"]; additional retaining bezel available	H57 and HC77	available in grey and black	298
	Bezel adapter for hole ø 60	H57 and HC77		299
	Front bezel F2B for cut-out 54 x 54 mm [2.126 x 2.126"], size F2 for one BVa or two B counter	BVa and B counter HVa and HB counter	plug in from front	299
	Front bezel F2M for cut-out 54 x 54 mm [2.126 x 2.126"], size F2 for one MVs or two M counter	MVs or M counter	plug in from front	299

## Overview

3.2 Socket boxes	Accessories	for counter types	Remarks	Page
	Socket box type 946.1	BVa	plug in from front plastic	300
	Socket box type 926.1	MVs	plug in from front	300

3.3 Sealing covers	Accessories	for counter types	Remarks	Page
	Flexible sealing cover for size F2, types K2, IP65	BVa and B counters, el. preset counters front bezel adapter 75 x 60 mm [2.953 x 2.363"]		300
	Sealing cover transparent for MVs 13 TypKV3, IP 65	MVs 13	Material: Steel	301
	Sealing cover transparent type 2 Dv for size F1, with gasket, IP 65	BVa and B counters, el. preset counters with adapter front bezel 75 x 60 mm [2.953 x 2.363"]		301
	Sealing cover with key-lock type 2 Dvs, IP 65 with gasket	BVa and B counter, el. preset counters with front bezel adapter 75 x 60 mm [2.953 x 2.363"]	with two keys	301
	Lockable transparent cover with bezel adapter for counters with dimensions 45 x 45 mm [1.772 x 1.772"] to cut-out 50 x 50 mm [1.969 x 1.969"]	901, 903, 904, 923, 924, 715 <b>CODIX</b> 716/717, 910		302
	Lockable transparent cover with bezel adapter for counters with dimensions 45 x 45 mm [1.772 x 1.772"] to cut-out 50 x 50 mm [1.969 x 1.969"]	901, 903, 904, 923, 924, 715 <b>CODIX</b> 716/717, 910		302

## Overview

4. Special accessories				
4.1 Front bezel	Accessories	for counter type	Remarks	Page
	Front bezel F3B, die-cast aluminium for cut-out 81 x 55 mm [3.189 x 2.166"]	1 x BVa, 1 x B or 3 x B, HVa and HB	available in black or beige	303
	Front bezel F4B die-cast aluminium for cut-out 25 x 50 mm [0.984 x 1.969"] with screw fixing	2 x Bva or 1 x Bva and 2 x B or 4 x B	available in black or beige	303
	Blind housing 13x for cut-out 22,2 x 45 mm and 25 x 50 mm	13x, 52x, Wxx.5x H37	complete with accessories	303
	Blind housing for cut-out 25 x 50 mm	B and HB	available in black	303
	Enclosure	Counter for cut-out 25 x 50 mm [0.984 x 1.969"], 22.2 x 45 mm [0.874 x 1.772"] with bezel adapter or 45 x 45 mm [1.772 x 1.772"]	available in two sizes	304
	Rail mount frames	BVa or B HVa or HB	available in 3 versions	305
	Terminal cover for H37	H37	transparent	305
	Add on socket for H57 and HC77 on DIN rail	H57, HC77	available in black	306

## EzControl



- Easy parameter software for counter type 716/717 and process displays 55x.
- Upload and download function
- Monitor- and terminal program for easy diagnostic functions
- Online display of the measurement values
- German and English.

EzControl software on CD

Order no. N 150.080

Accessories:

RS 232 interface cable to the counter

Order no. N 140.076

RS 232 <=> RS 485/422 interface converter with power supply 90 ... 250 V AC (50 or 60 Hz) and cable to counter

Order no. N 150.002

RS 232 <=> RS 485/422 interface converter with power supply and cable to counter for the US market (110 V AC)

Order no. N 150.003

**Adapters**

Bezel adapter **37.1**

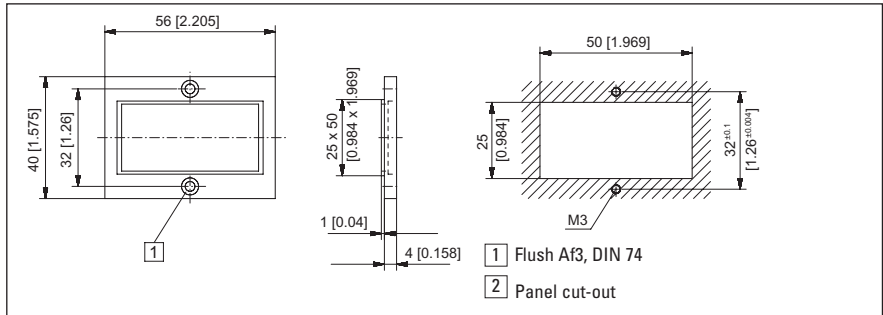

Suitable for Process Displays **CODIX** 529, 530, 531 and 532

<b>Order code:</b>	
grey:	Art. no. T008 160
anthracite:	Art. no. T008 181
black:	Art. no. T008 161

Slip-on bezel **37.2**

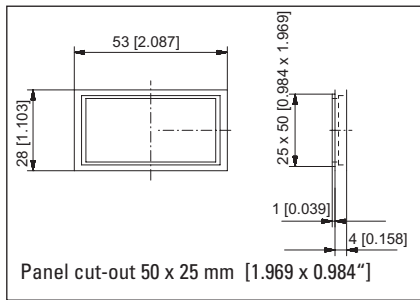

Suitable for counters:  
W15.5, W16.5, W17.5,  
**CODIX** 13x, **CODIX** 52x, H37

<b>Order code:</b>	
grey:	Art. no. T008 164
anthracite:	Art. no. T008 180
black:	Art. no. T008 165

Adapter bezel for cut-out  
68 x 33 mm [2.677 x 1.299"]

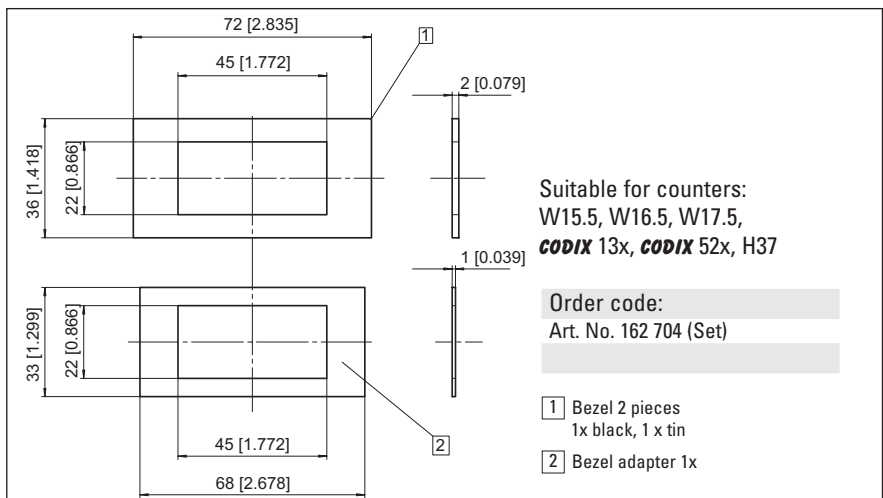

Suitable for counters:  
W15.5, W16.5, W17.5,  
**CODIX** 13x, **CODIX** 52x, H37

<b>Order code:</b>	
Art. No. 162 704 (Set)	

- 1 Bezel 2 pieces  
1x black, 1 x tin
- 2 Bezel adapter 1x

**Bezels and Sealing Covers**

Bezel adapter for panel cut-out 29 x 55 mm [1.142 x 2.166"]



Suitable for counters: **CODIX 13x**, **CODIX 52x**, W15.5, W16.5, W17.5

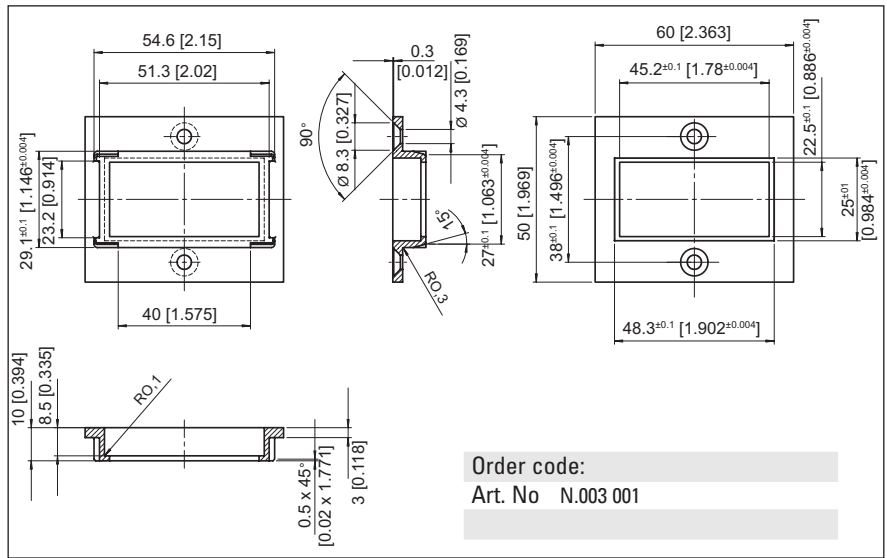

Bezel adapter for panel cut out 45 x 45 mm [1.772 x 1.772"] to 22.2 x 45 mm [0.874 x 1.772"]



Suitable for counters: **CODIX 13x**, **CODIX 52x**, W15.5, W16.5, W17.5

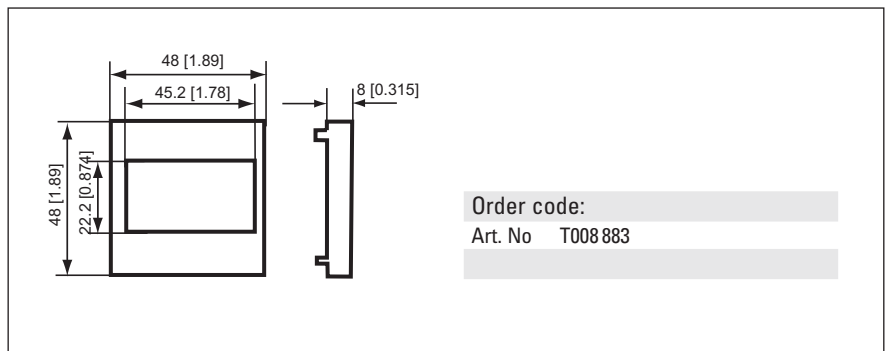

**Type F1B**

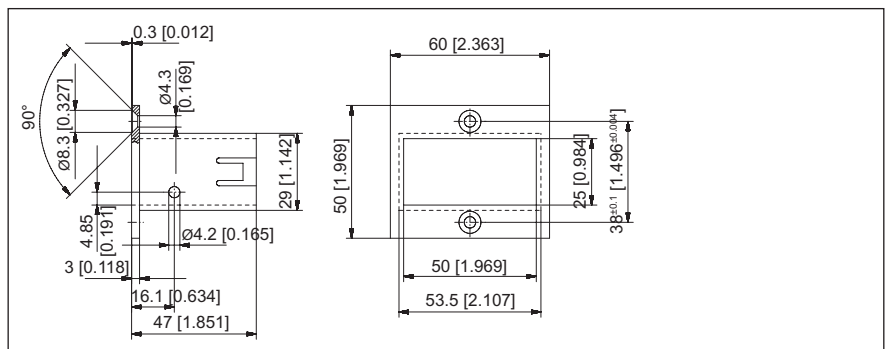

- Plastic front bezel F1B for counters with panel cut-outs 50 x 25 mm [1.969 x 0.984"].
- The counters plug into the respective socket box.

Order code:

F1B	beige	Art. No. G.007 501
F1B	black	Art. No. G.007 502

**Socket boxes**

Type 945.2



Suitable for counters:  
B and HB

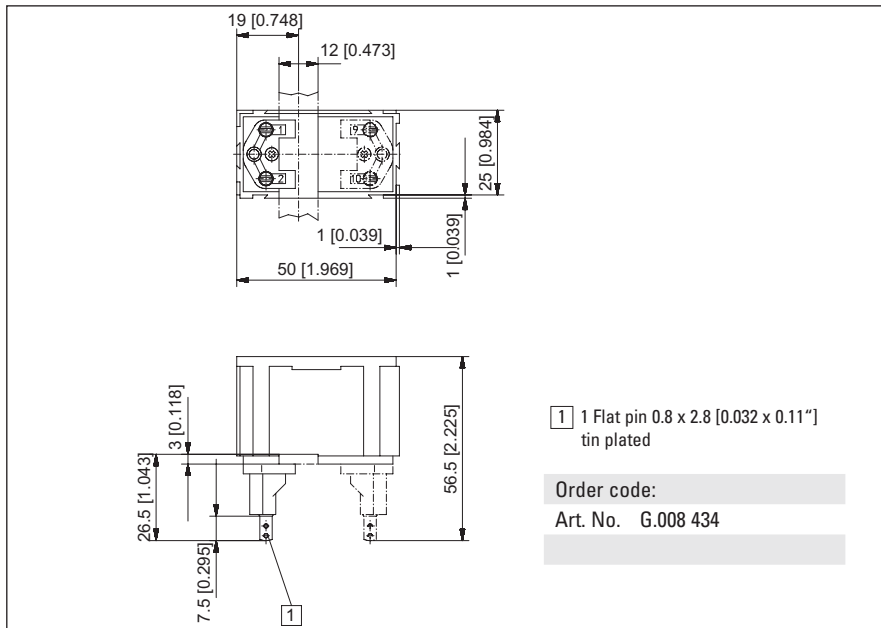

**Flexible sealing cover**

Type K 1



Suitable for counter types:  
B 15.31, B16.31, B 16.30, B 18.30,  
F1 B15.01, F1 B 16.01, F1 B 16.00,  
F1 B18.00.

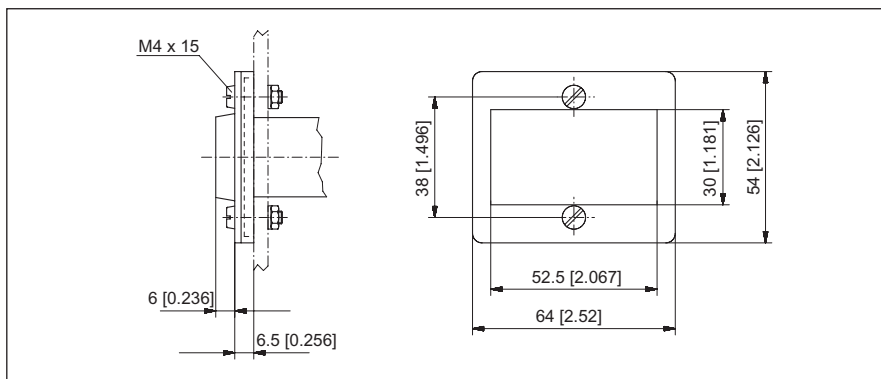

- Flexible sealing cover made of soft PVC, with varnished steel metal frame and fixing screws
- IP 54 protection to DIN 40050 when installed.

Order code:  
grey Art. No. G.008 300  
black Art. No. G.008 301

**Sealing cover**

Transparent cover with key-lock 1 Dv



Suitable for counters:  
H, B, HB or counters 24 x 48 mm [0.945 x 1.89"]  
in bezel adapter 50 x 60 mm [1.969 x 2.363"]

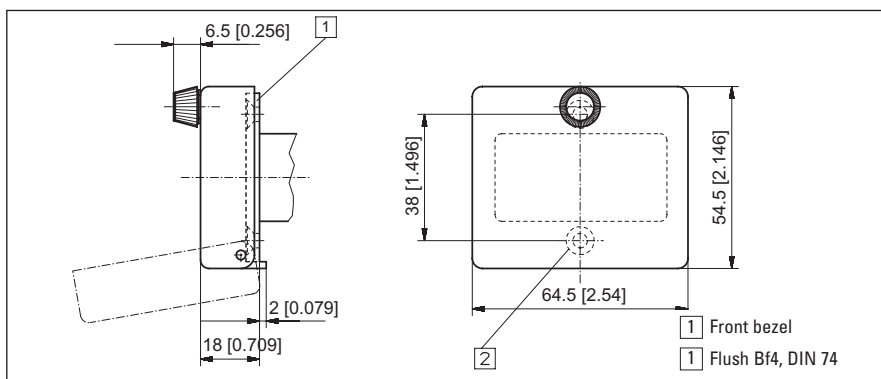

- Screw-on transparent cover, 1 Dv, with key locking for size F1
- IP 65 protection with front bezel

Order code:  
grey Art. No. N.003 002



**Sealing cover**

**Transparent cover with key-lock 1 Dv**

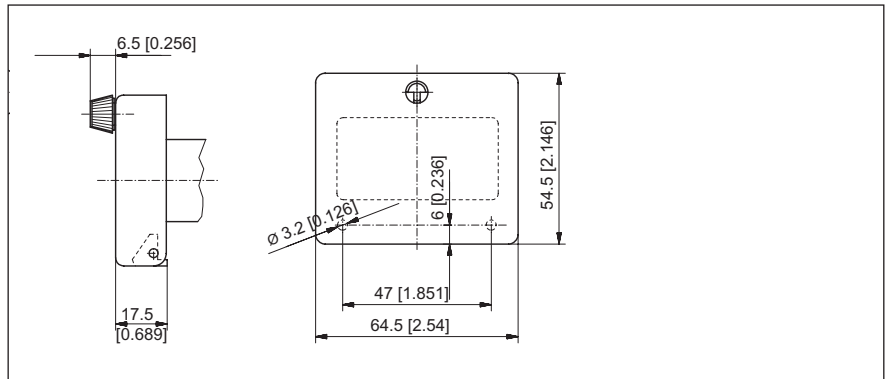

Suitable for counters:  
H, B, HB or counters 24 x 48 mm [0.945 x 1.89"]  
in bezel adapter 50 x 60 mm [1.969 x 2.363"]

- Screw-on transparent cover, 1 Dv, with key locking for size F1
- IP 65 protection
- With gaskets and screws

Order code:  
grey Art. No. G008 121

**Transparent cover with key lock 1 Dvs**

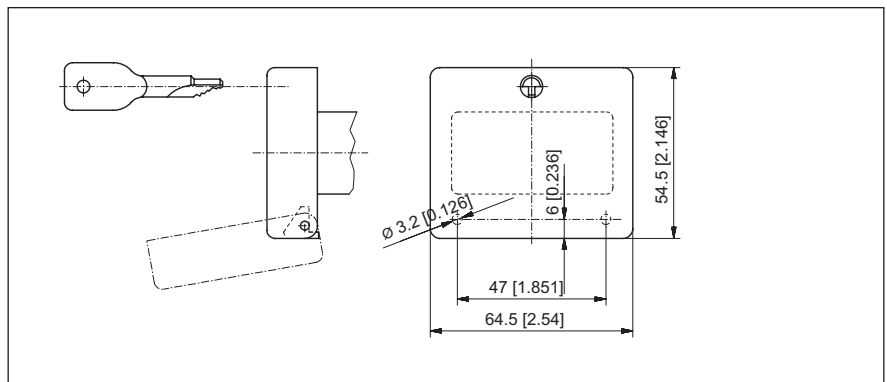

Suitable for counters:  
H, B, HB or counters 24 x 48 mm [0.945 x 1.89"]  
in bezel adapter 50 x 60 mm [1.969 x 2.363"]

- Screw-on transparent cover, 1 Dvs, with key locking for size F1
- IP 65 protection
- With gaskets and screws

Order code:  
grey Art. No. N008 131

**Bezels**

**Slip-on bezel 55**

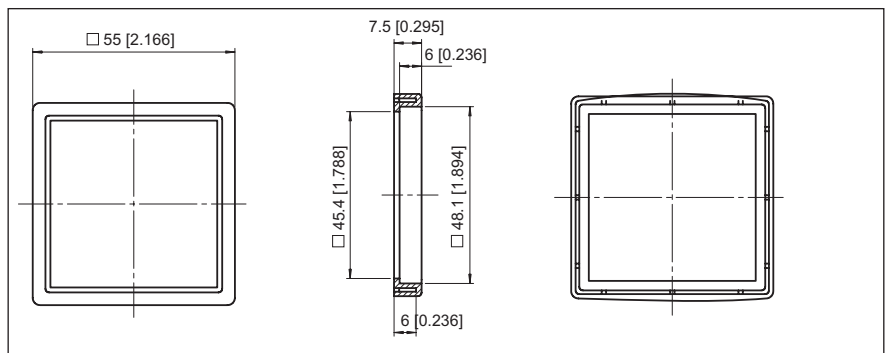

Suitable for counters:  
715, CODIX 716, CODIX 717, 901, 903,  
904, 923, 924, H57 and HC77

- Bezel adapter 55 x 55 mm [2.166 x 2.166"] for adapting cut-out 50 x 50 mm [1.969 x 1.969"] to 45 x 45 mm [1.772 x 1.772"]

Order code:  
black Art. No. T 008 171  
grey Art. No. T 008 170

**Bezel**

**Slip-on bezel 55**

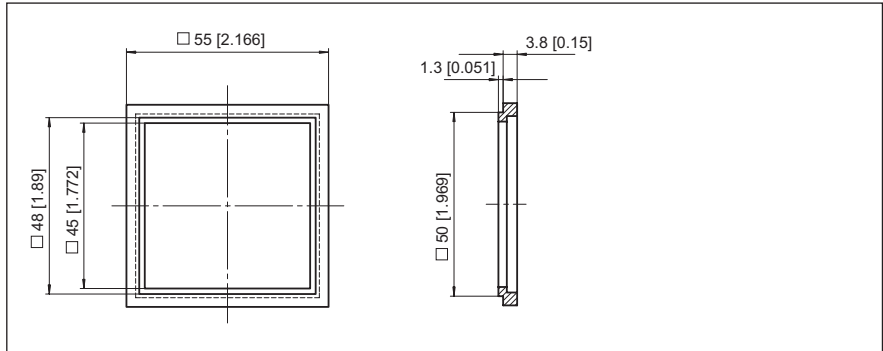

Suitable for counters:  
901, 903, 904, 923, 924, 715,  
**CODIX** 716/717, 910

• Bezel adapter for el. counters with panel  
cut-out 45 x 45 mm [1.772 x 1.772"]

Order code:  
black Art. No. T 008 853

**Bezel adapter 45**

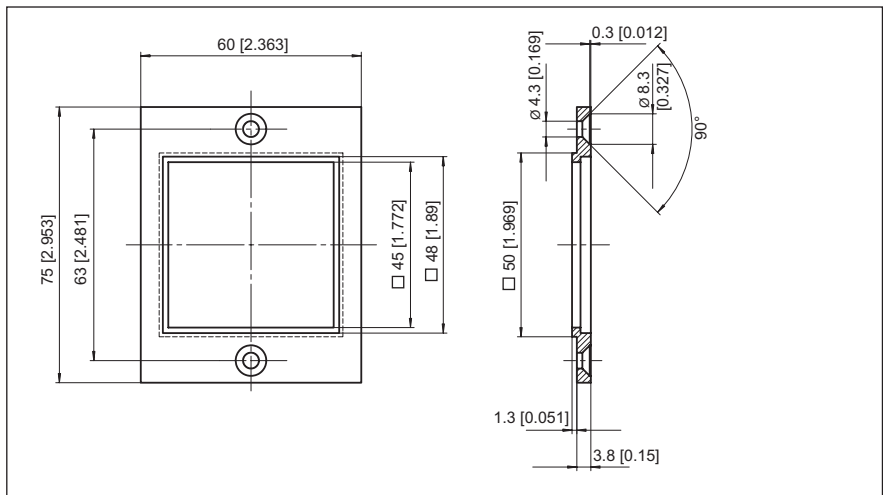

Suitable for counters:  
901, 903, 904, 923, 924, 715,  
**CODIX** 716/717, 910

• Bezel adapter 50 x 50 mm [1.969 x 1.969"] to  
45 x 45 mm [1.772 x 1.772"] for screw fixing

Order code:  
black Art. No. T 008 860

**Slip-on bezel 72**

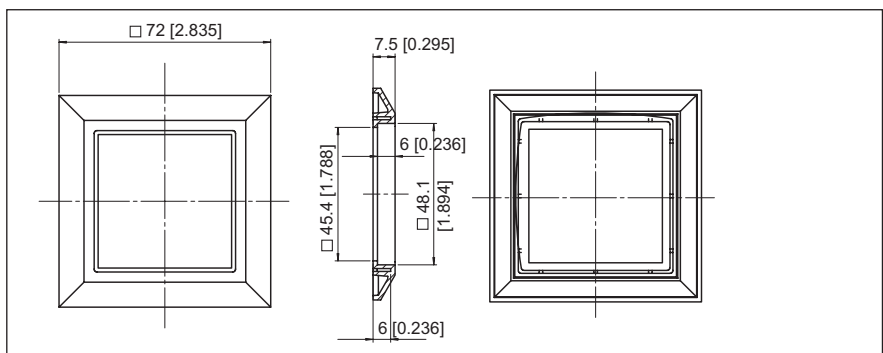

Suitable for counters:  
715, **CODIX** 716, **CODIX** 717, 901,  
903, 904, 923, 924, H57 and HC77

Order code:  
black Art. No. T 008 177  
grey Art. No. T 008 176

Arrester Art. No. T 009 420

**Bezel**

Slip-on bezel for bore  $\varnothing$  60 [2.362"]



Suitable for counters:  
715, **CODIX** 716, **CODIX** 717, 901,  
903, 904, 923, 924, H57 and HC77

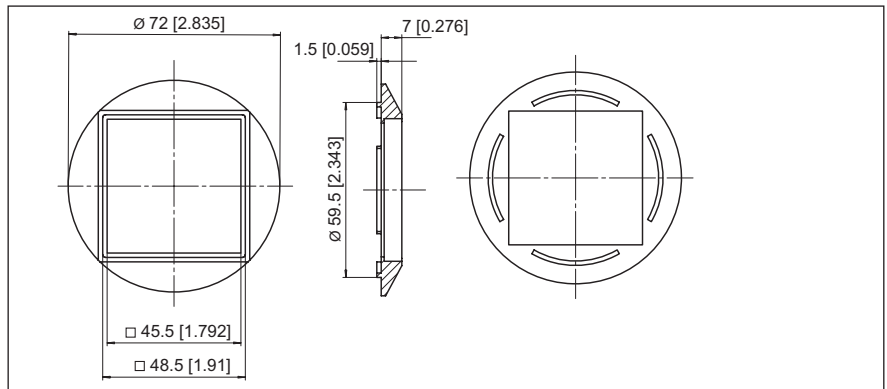

Order code:  
black Art. No. N 510226

Type F2B



- Plastic front bezel F2B for counters with panel cut-out dimensions 50 x 50 mm [1.969 x 1.969"]
- Suitable for counters Hva and HB

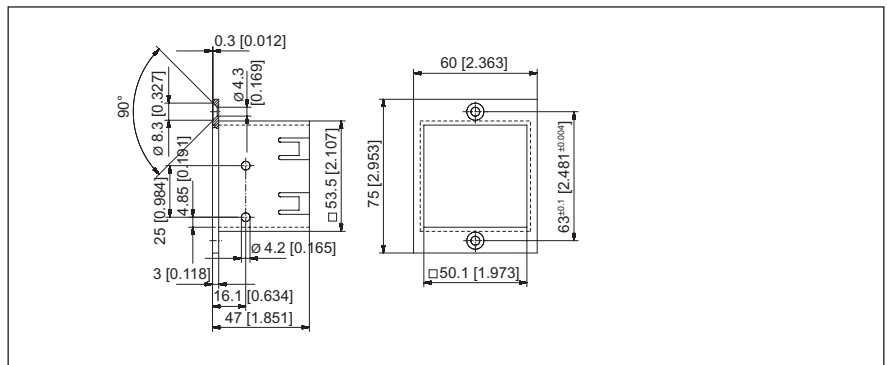

Order code:  
F2B beige Art. No. G.007.503  
F2B black Art. No. G.007.504

Type F2M



Suitable for counter  
MVs or M

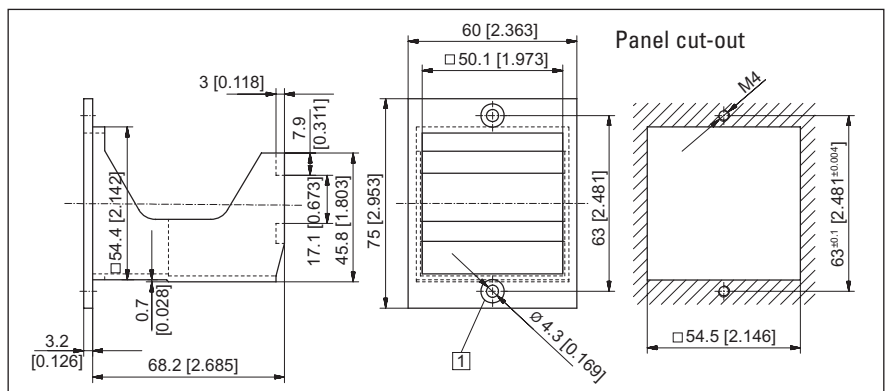

1 Flush, Bf4, DIN 74

Order code:  
F2M beige Art. No. T.008.105  
F2M black Art. No. T.008.106

## Socket boxes

### Socket box 946.1

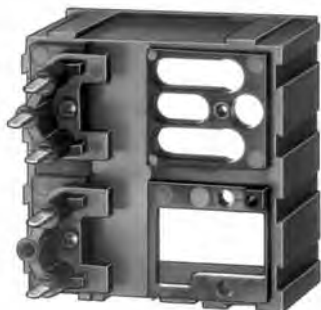

Suitable for counter: B Va

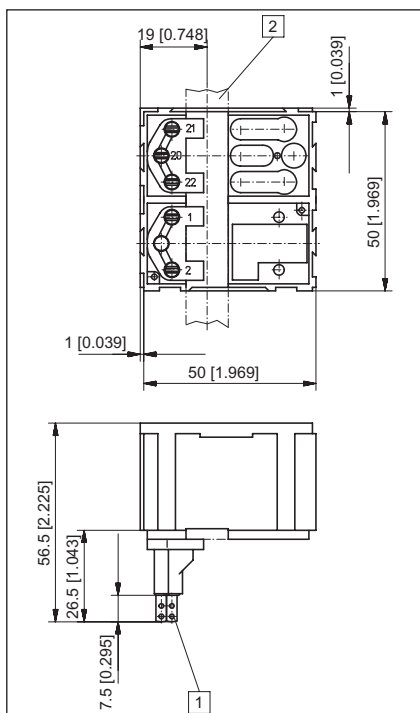

- 1 Flat pin 0.8 x 2.8 mm [0.032 x 0.11"] tin plated
- 2 Fixing strip 3 x 12 mm [0.118 x 0.473"]

Order code:  
Art. No. G.008 439

### Socket boxes 926.1



Suitable for counter MVs

Order code:  
Art. No. G008 433

## Sealing covers

### Type K 2



Suitable for counters:  
BVa and B or el. preset counters with  
bezel adapter 75 x 60 mm [2.953 x 2.363"]

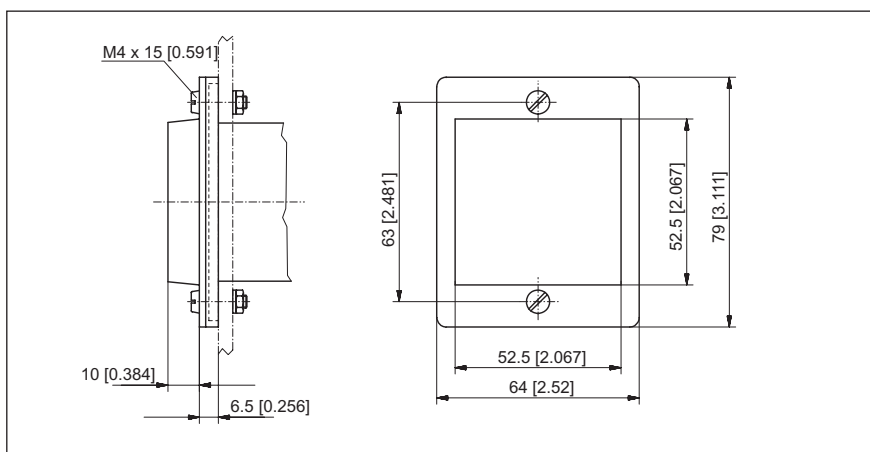

Order code:  
grey Art. No. G008302  
black Art. No. G008303

**Sealing covers**

**Type KV3**



Suitable for counter:  
MVs 13

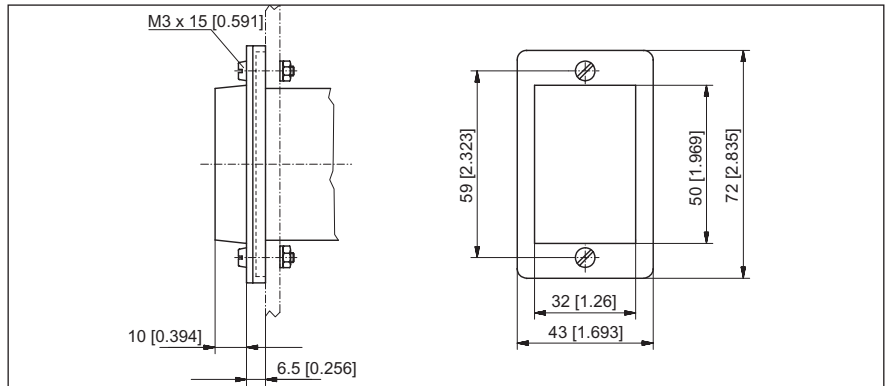

Order code:

grey	Art. No.	G008 310
black	Art. No.	G008 311

**Type 2 Dv**



Suitable for counters:  
BVa and B or el. preset counters with  
bezel adapter 75 x 60 mm [2.953 x 2.363"]

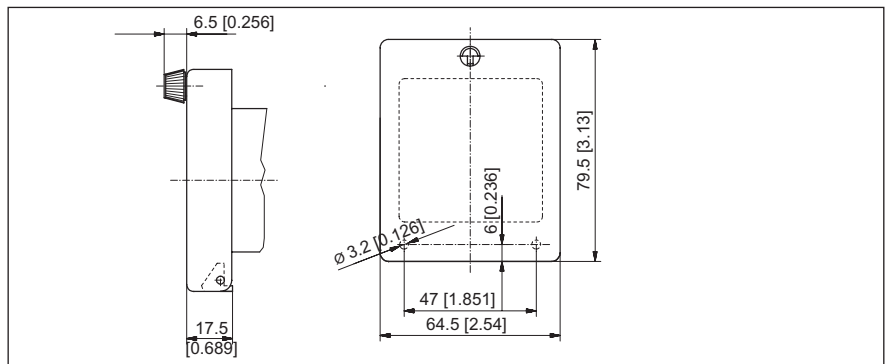

Order code:

Art. No.	G008 141
----------	----------

- Screw-on transparent cover, 2 Dv, with key locking for size 2
- IP 65 protection
- With gaskets and screws

**Type 2 Dvs**



Suitable for counters:  
BVa and B or el. preset counters with  
bezel adapter 75 x 60 mm [2.953 x 2.363"]

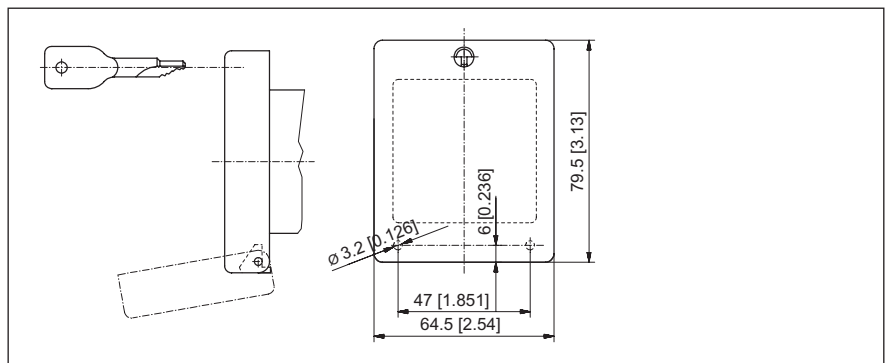

Order code:

grey	Art. No.	G008 151
------	----------	----------

- Screw-on transparent cover, 2 Dvs, with key locking for size 2
- IP 65 protection
- With gaskets and screws

## Sealing covers

### Lockable transparent cover



Suitable for counter:  
901, 903, 904, 923, 924, 715  
**codix** 716/717, 910

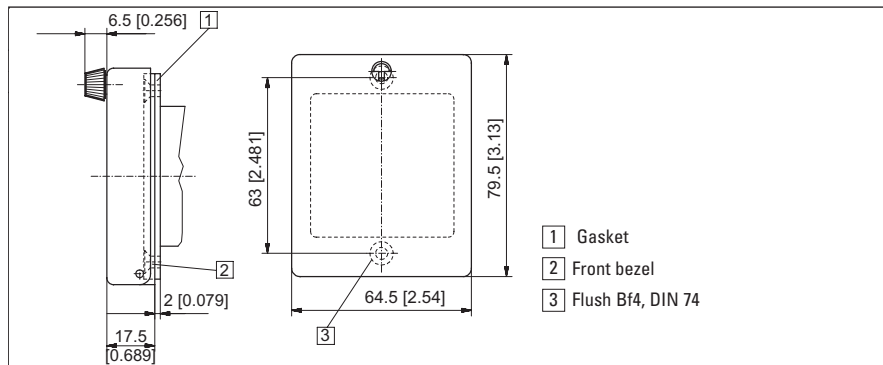

Order code:

Art. No. G008 143

### Lockable transparent cover, with key



Suitable for counter:  
901, 903, 904, 923, 924, 715  
**codix** 716/717, 910

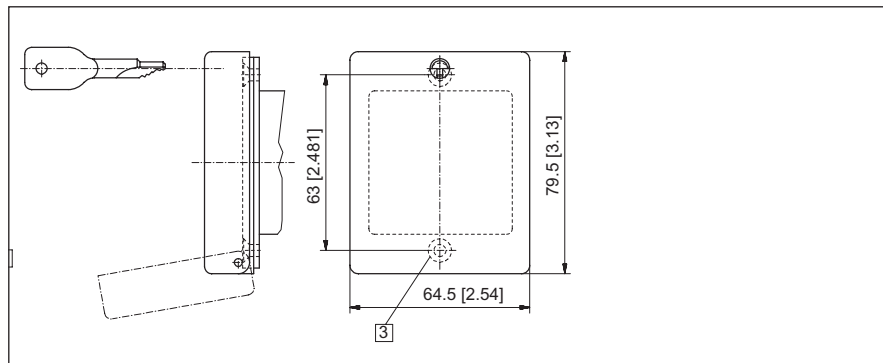

Order code:

Art. No. G008153

**Front bezels**

Type F3B  
Type F4B



Suitable for counter:  
1 x BVa, 1x B, 3 x B or HVa and HB

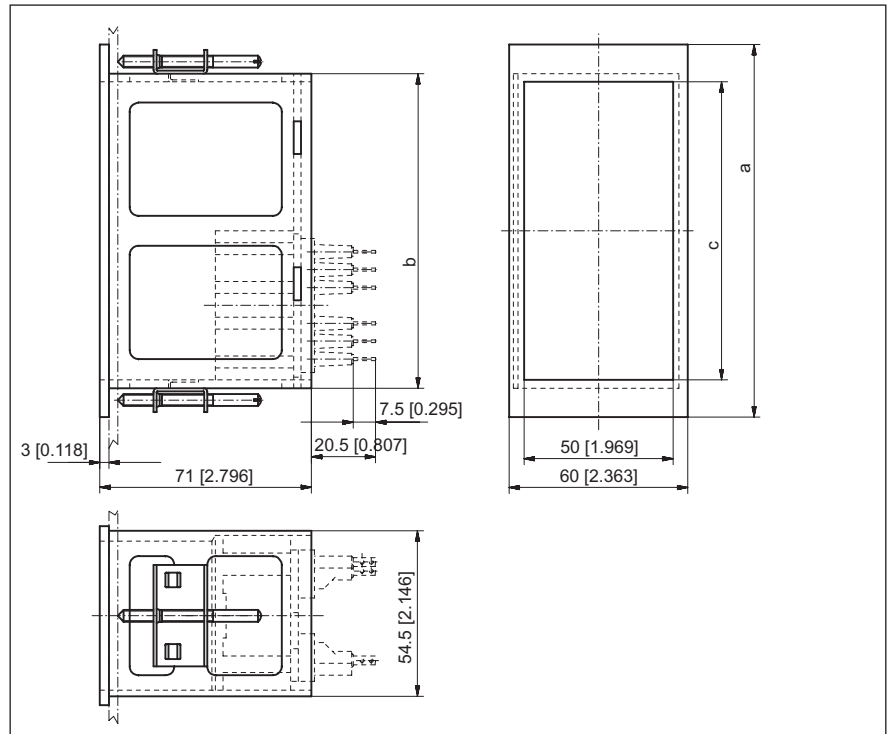

Front bezel	a	b	c
F3B	100	80,5	75
F4B	125	105,5	100

Order code		
F3B	Art. No.	G007 506
F4B	Art. No.	G007 509

**Enclosure Blind 13x**

Enclosure Blind  
for cut out 22,2 x 45 and 25 x  
50 in Codix Design



Order code:		
Art. No.	G003 836	
with accessories		

**Enclosure Blind**

Enclosure Blind  
for cut out 25 x 50

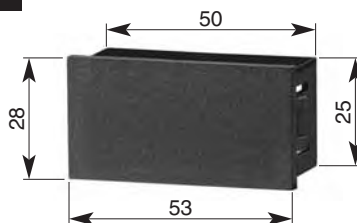

Order code:	
Art. No.	T005 753 black
Art. No.	T005 752 grey

Enclosure



- For panel-mounting all counters, timers and process indicators, with DIN size 24 x 48 mm [0.945 x 1.89"] or 50 x 25 mm [1.969 x 0.984"], such as **CODIX 52X**, **CODIX 53X**, **CODIX 13X** as well as electromechanical pulse counters and hour meters, such as H37, W17.50 etc.

**Note:**  
when mounting the DIN 24 x 48 mm [0.945 x 1.89"] units in the enclosure, please use the 50 x 25 mm [1.969 x 0.984"] panel

**Dimensions:**

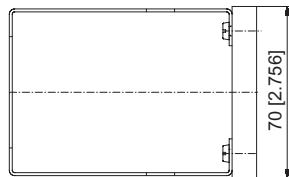
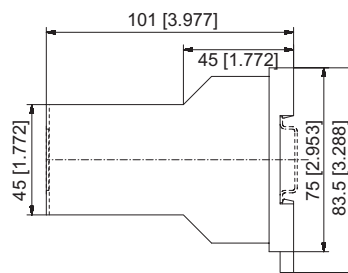

- adapter, which is provided with all electronic products
- Cut-out 25 x 50 mm [0.984 x 1.969"]
- For snap-on fitting to 35 mm [1.378"] top hat DIN rails
- Construction: Mounting panel for counter: chrome-plated sheet steel  
Top hat DIN rail adapter: glass fibre reinforced polyamide
- Applications include, for example, control cabinets

Order code: G.300.004

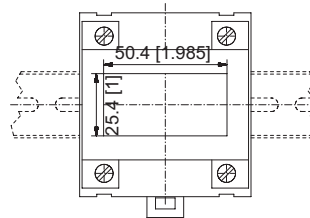

**Further Accessories:**

Bezel 25 x 50 mm [0.984 x 1.969"] for electromechanical counter with built-in dimension 22 x 45 mm [0.866 x 1.772"]

Order code: T.008.180



- For panel-mounting all counters and timers of DIN size 48 x 48 mm [1.89 x 1.89"], for example preset counter 715, **CODIX 716/717**, 901, 903/904, 923, 924 or time relay 910
- Cut-out □ 45 mm [1.772"]
- For snap-on fitting to 35 mm [1.378"] top hat DIN rails

- Construction:  
Mounting panel for counter: chromate passivation sheet steel  
Top hat DIN rail adapter: glass fibre reinforced polyamide
- Applications include for example control cabinets

Order code: G.300.003

**Dimensions:**

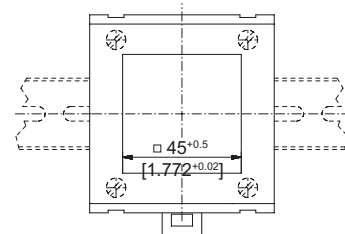
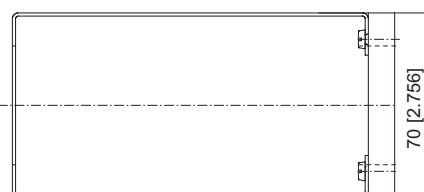
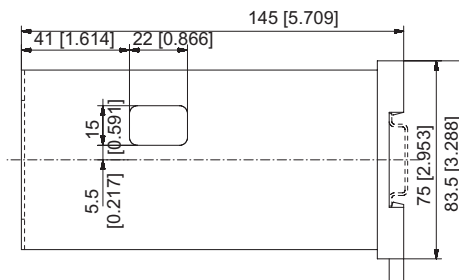



**Rail mount frames SR 1, SR 2 and SR 3**

Type SR 3

Type SR 1

Type SR 2

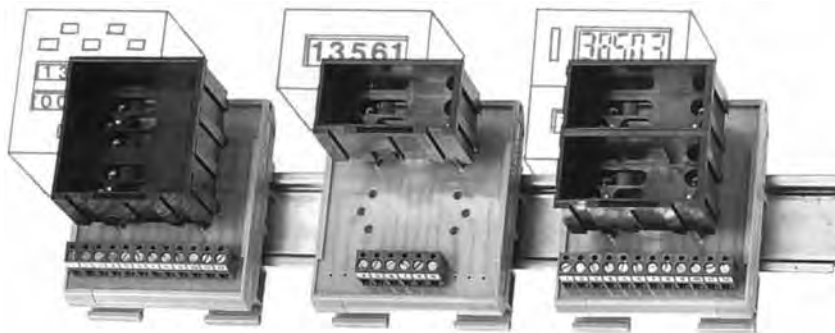

- SR1, SR2 and SR3 frames for rail mount can be snapped onto rails TS 35 x 7.5 mm [1.378 x 0.295"] and TS 35 x 15 mm [1.378 x 0.591"] as per DIN EN 50 022 respectively as per DIN EN 50 035
- Electronic and electromechanical totaliser, present counters or hour meters may be plugged into the built-in socket

**Applications:**

electric switch or distribution box etc.

**Connection:**

Count mode	Type series	Frame	Counter position with SR 2 frame	Count input Terminal number
Adding counter	B 16.01, B 18.00	SR 1		7+8
		SR 2	top bottom	7+8 10+12

**Order code:**

- SR 1: Art.-No. G 300 000
- SR 2: Art.-No. G 300 001
- SR 3: Art.-No. G 300 002

**Dimensions:**

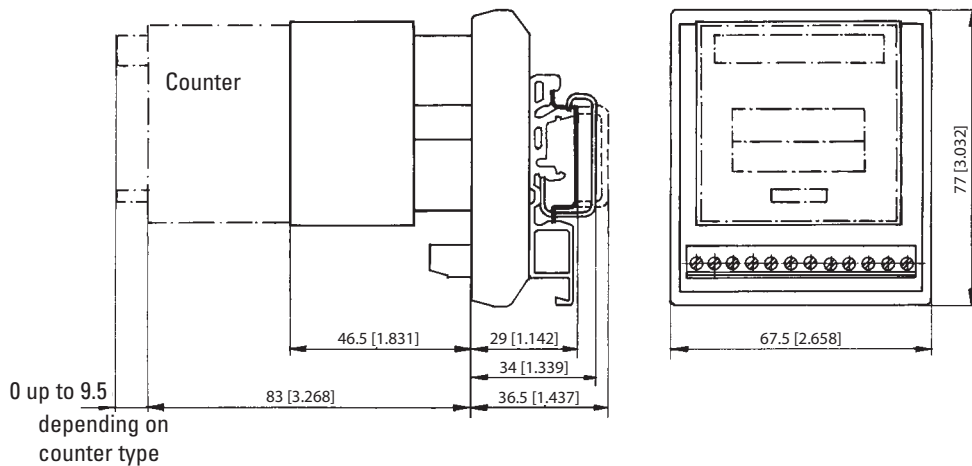

**Terminal cover KA 37**



Art. No. T051.687  
(2-pcs. per counter required)

**Add-on socket for H57, AH 57**

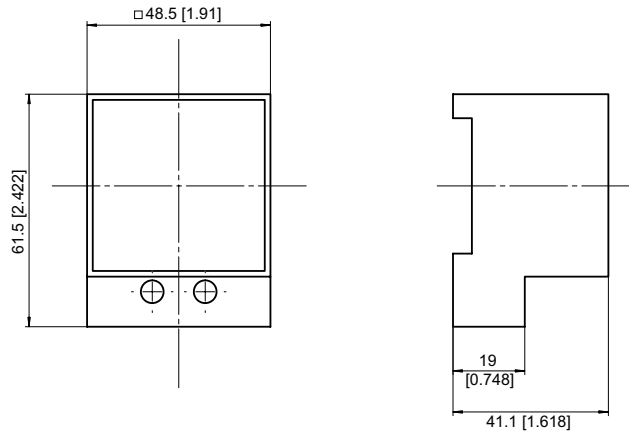

Order code:			
black	Art.-No.	G008 040	
grey	Art.-No.	G008 041	

**Overview of sealing gaskets**

Art. No.	Sealing gaskets for			External dimensions (A)	Internal dimensions (B)
	Front bezel/Type	Cover	Add-on socket		
N.511003	F2 D			60 x 75 [2.363 x 2.953"]	54.4 x 54.4 [2.142 x 2.142"]
N.511004		F2 D		58 x 58 [2.284 x 2.284"]	50.2 x 50.2 [1.977 x 1.977"]
N.511005	F1 D			60 x 50 [2.363 x 1.969"]	54.4 x 29.4 [2.142 x 1.158"]
N.511006		F1 D		58 x 33 [2.284 x 1.299"]	5.2 x 25.2 [1.977 x 0.992"]
N.511011	MK 14.1 MK 16.10 HK 17.151			39 x 40 [1.536 x 1.575"]	33.3 x 22 [1.311 x 0.866"]
N.511015	H 37.2, H 37.4 HB 26.21, HB 27.00			53 x 28 [2.087 x 1.103"]	50 x 25 [1.969 x 0.984"]
N.511016	H 57.72			72 x 72 [2.835 x 2.835"]	∅ 50,5 / 45 [1.988 / 1.772"]
N.511017	H 57.55			55 x 55 [2.166 x 2.166"]	∅ 50,5 / 45 [1.988 / 1.772"]
N.511018	H 57			48 x 48 [1.89 x 1.89"]	∅ 50 / 45 [1.969 / 1.772"]
N.511019	Panel cut-out cross section 25 x 50 mm [0.984 x 1.969"] and front bezel size 3			60 x 50 [2.363 x 1.969"]	50 x 25 [1.969 x 0.984"]
N.511020	Panel cut-out cross section 50 x 50 mm [1.969 x 1.969"] and front plate size 3			60 x 75 [2.363 x 2.953"]	50 x 50 [1.969 x 1.969"]
N.511028	901 ... 904, 923, 924			48 x 48 [1.89 x 1.89"]	45 x 45 [1.772 x 1.772"]
N.511029	H 37, H 37.5, 520 ... 530			48 x 24 [1.89 x 0.945"]	45 x 22 [1.772 x 0.866"]
N.511030	HK 17.611			55 x 31.5 [2.166 x 1.286"]	37 x 24 [1.061 x 0.945"]
N.511031	54X , 55X			96 x 49 [3.78 x 1.929"]	92 x 45 [3.622 x 1.772"]
N.511033	715, 901 ... 904, 923, 924			49 x 49 [1.929 x 1.929"]	45 x 45 [1.772 x 1.772"]
N.511034	520 ... 529			49 x 25 [1.929 x 0.984"]	45 x 22 [1.772 x 0.866"]
N.511040	HK 17.251			37 x 26 [1.457 x 1.024"]	33.3 x 22 [1.311 x 0.866"]
N.511043	HK 17.451			55 x 26 [2.166 x 1.061"]	33.3 x 22 [1.311 x 0.866"]
N.511150	HR 76.1			∅ 71.1 [2.799"]	∅ 50.8 [2"]

# Cross-reference Table Order Code – Type



Order code	Type	Page
0.135.100.301	HR 76.1, 115 VAC	179
0.135.100.302	HR 76.1, 230 VAC	179
0.135.100.373	HR 76.1, 10-80 VDC	179
0.135.200.301	HR 76.2, 115 VAC	179
0.135.200.302	HR 76.2, 230 VAC	179
0.135.200.373	HR 76.2, 10 - 80 VDC	179
0.166.012.830	166	118
0.167.012.000	167	119
0.168.012.000	168	119
0.170.000.351	SH 17, 10 - 27 VDC	185
0.170.000.075	SH 17, 230 VAC	185
0.180.200.000	180	120
0.180.300.000	180	120
0.570.011.E00	570	121-287
0.570.012.E90	570	121-287
0.570.012.E05	570	121-287
0.571.011.E00	571	122-144- 224-264- 286
0.571.012.E90	571	122-144- 224-264- 286
0.571.012.E05	571	122-144- 224-164- 286
0.910.010.800	910	228
1.100.200.XXX	K 04.20, DC	45
1.100.200.XXX	K 04.20, AC	45
1.100.401.XXX	K 04.40, DC	46
1.100.501.XXX	K 04.50, DC	47
1.100.800.XXX	K 04.80, DC	48
1.110.000.XXX	AK 05.00, DC	49
1.110.000.XXX	AK 05.00, AC	49
1.110.200.XXX	K 05.20, DC	45
1.110.200.XXX	K 05.20, AC	45
1.110.401.XXX	K 05.40, DC	46
1.110.501.XXX	K 05.50, DC	47
1.110.800.XXX	K 05.80, DC	48
1.120.000.XXX	AK 06.00, DC	49
1.120.000.XXX	AK 06.00, AC	49
1.120.200.XXX	K 06.20, DC	45
1.120.200.XXX	K 06.20, AC	45
1.120.401.XXX	K 06.40, DC	46
1.120.501.XXX	K 06.50, DC	47
1.120.800.XXX	K 06.80, DC	48
1.120.800.XXX	K 06.80, AC	48
1.120.900.XXX	K 06.90, DC	50
1.120.900.XXX	K 06.90, AC	50
1.120.920.XXX	K 06.92, DC	51
1.120.920.XXX	K 06.92, AC	51
1.122.101.XXX	SK 06.1, DC	53
1.122.101.XXX	SK 06.1, AC	53
1.130.000.006	AK07.00, 3VDC/0	49
1.130.000.008	AK07.00, 4.5VDC/0	49
1.130.000.012	AK07.00, 12VDC/0	49
1.130.000.032	AK07.00, 12VDC/I	49
1.130.000.033	AK07.00, 24VDC/I	49
1.130.000.051	AK07.00, 24VAC/a0	49
1.130.000.054	AK07.00, 115VAC/a0	49
1.130.000.056	AK07.00, 230VAC/a0	49
1.130.200.006	K 07.20, 3 VDC/0	45
1.130.200.008	K 07.20, 4.5 VDC/0	45

Order code	Type	Page
1.130.200.012	K 07.20, 12 VDC/0	45
1.130.200.032	K 07.20, 12 VDC/I	45
1.130.200.033	K 07.20, 24 VDC/I	45
1.130.200.051	K 07.20, 24 VAC/a0	45
1.130.200.054	K 07.20, 115 VAC/a0	45
1.130.200.056	K 07.20, 230 VAC/a0	45
1.130.401.006	K 07.40, 3 VDC/0	46
1.130.401.008	K 07.40, 4.5 VDC/0	46
1.130.401.012	K 07.40, 12 VDC/0	46
1.130.401.032	K 07.40, 12 VDC/I	46
1.130.401.033	K 07.40, 24 VDC/I	46
1.130.501.006	K 07.50, 3 VDC/0	47
1.130.501.008	K 07.50, 4.5 VDC/0	47
1.130.501.012	K 07.50, 12 VDC/0	47
1.130.501.032	K 07.50, 12 VDC/I	47
1.130.501.033	K 07.50, 24 VDC/I	47
1.130.800.006	K 07.80, 3 VDC/0	48
1.130.800.008	K 07.80, 4.5 VDC/0	48
1.130.800.012	K 07.80, 12 VDC/0	48
1.130.800.032	K 07.80, 12 VDC/I	48
1.130.800.033	K 07.80, 24 VDC/I	48
1.130.800.051	K 07.80, 24 VAC/a0	48
1.130.800.054	K 07.80, 115 VAC/a0	48
1.130.800.056	K 07.80, 230 VAC/a0	48
1.130.900.006	K 07.90, 3 VDC/0	50
1.130.900.008	K 07.90, 4.5 VDC/0	50
1.130.900.012	K 07.90, 12 VDC/0	50
1.130.900.032	K 07.90, 12 VDC/I	50
1.130.900.033	K 07.90, 24 VDC/I	50
1.130.900.051	K 07.90, 24 VAC/a0	50
1.130.900.054	K 07.90, 115 VAC/a0	50
1.130.900.056	K 07.90, 230 VAC/a0	50
1.130.920.006	K 07.92, 3 VDC/0	51
1.130.920.008	K 07.92, 4.5 VDC/0	51
1.130.920.012	K 07.92, 12 VDC/0	51
1.130.920.032	K 07.92, 12 VDC/I	51
1.130.920.033	K 07.92, 24 VDC/I	51
1.130.920.051	K 07.92, 24 VAC/a0	51
1.130.920.054	K 07.92, 115 VAC/a0	51
1.130.920.056	K 07.92, 230 VAC/a0	51
1.132.101.012	SK 07.1, 12 VDC/0	53
1.132.101.013	SK07.1, 24VDC/0,sw	53
1.132.101.032	SK 07.1, 12 VDC/I	53
1.132.101.033	SK 07.1, 24 VDC/I	53
1.132.101.051	SK 07.1, 24 VAC/a0	53
1.132.101.054	SK 07.1, 115 VAC/a0	53
1.132.101.056	SK 07.1, 230 VAC/a0	53
1.150.010.012	W 15.01, 12 VDC/0	55
1.150.010.013	W 15.01, 24 VDC/0	55
1.150.010.049	W 15.01, 12 VDC/05	55
1.150.010.050	W 15.01, 24 VDC/05	55
1.150.010.051	W 15.01, 24 VAC/a0	55
1.150.010.054	W 15.01, 115 VAC/a0	55
1.150.010.056	W 15.01, 230 VAC/a0	55
1.150.21X.012.XXX	W 15.21, 12 VDC/0	55
1.150.21X.013.XXX	W 15.21, 24 VDC/0	55
1.150.21X.049.XXX	W 15.21, 12 VDC/05	55
1.150.21X.050.XXX	W 15.21, 24 VDC/05	55
1.150.21X.051.XXX	W 15.21, 24 VAC/a0	55
1.150.21X.054.XXX	W 15.21, 115 VAC/a0	55
1.150.21X.056.XXX	W 15.21, 230 VAC/a0	55
1.150.510.XXX	W15.51, DC	56

# Cross-reference Table Order Code – Type



Order code	Type	Page
1.150.510.XXX	W15.51, AC	56
1.150.910.012	W 15.91, 12 VDC/0	56
1.150.910.013	W 15.91, 24 VDC/0	56
1.150.910.049	W 15.91, 12 VDC/05	56
1.150.910.050	W 15.91, 24 VDC/05	56
1.150.910.051	W 15.91, 24 VAC/a0	56
1.150.910.054	W 15.91, 115 VAC/a0	56
1.150.910.056	W 15.91, 230 VAC/a0	56
1.152.011.012	AW 15.01, 12 VDC/0	56
1.152.011.013	AW 15.01, 24 VDC/0	56
1.152.011.049	AW 15.01, 12 VDC/05	56
1.152.011.050	AW 15.01, 24 VDC/05	56
1.152.011.051	AW 15.01, 24 VAC/a0	56
1.152.011.054	AW 15.01, 115 VAC/a0	56
1.152.011.056	AW 15.01, 230 VAC/a0	56
1.160.000.012	W 16.00, 12 VDC/0	58
1.160.000.013	W 16.00, 24 VDC/0	58
1.160.000.049	W 16.00, 12 VDC/05	58
1.160.000.050	W 16.00, 24 VDC/05	58
1.160.000.051	W 16.00, 24 VAC/a0	58
1.160.000.054	W 16.00, 115 VAC/a0	58
1.160.000.056	W 16.00, 230 VAC/a0	58
1.160.200.012	W 16.20, 12 VDC/0	58
1.160.200.013	W 16.20, 24 VDC/0	58
1.160.200.049	W 16.20, 12 VDC/05	58
1.160.200.050	W 16.20, 24 VDC/05	58
1.160.200.051	W 16.20, 24 VAC/a0	58
1.160.200.054	W 16.20, 115 VAC/a0	58
1.160.200.056	W 16.20, 230 VAC/a0	58
1.160.400.012	W 16.40, 12 VDC/0	59
1.160.400.013	W 16.40, 24 VDC/0	59
1.160.400.049	W 16.40, 12 VDC/05	59
1.160.400.050	W 16.40, 24 VDC/05	59
1.160.400.051	W 16.40, 24 VAC/a0	59
1.160.400.054	W 16.40, 115 VAC/a0	59
1.160.400.056	W 16.40, 230 VAC/a0	59
1.160.500.XXX	W16.50, DC	59
1.160.500.XXX	W16.50, AC	59
1.160.601.012	W 16.60, 12 VDC/0	60
1.160.601.013	W 16.60, 24 VDC/0	60
1.160.601.049	W 16.60, 12 VDC/05	60
1.160.601.050	W 16.60, 24 VDC/05	60
1.160.701.012	W 16.70, 12 VDC/0	60
1.160.701.013	W 16.70, 24 VDC/0	60
1.160.701.049	W 16.70, 12 VDC/05	60
1.160.701.050	W 16.70, 24 VDC/05	60
1.160.800.012	W 16.80, 12 VDC/0	61
1.160.800.013	W 16.80, 24 VDC/0	61
1.160.800.049	W 16.80, 12 VDC/05	61
1.160.800.050	W 16.80, 24 VDC/05	61
1.160.800.051	W 16.80, 24 VAC/a0	61
1.160.800.054	W 16.80, 115 VAC/a0	61
1.160.800.056	W 16.80, 230 VAC/a0	61
1.160.900.012	W 16.90, 12 VDC/0	60
1.160.900.013	W 16.90, 24 VDC/0	60
1.160.900.049	W 16.90, 12 VDC/05	60
1.160.900.050	W 16.90, 24 VDC/05	60
1.160.900.051	W 16.90, 24 VAC/a0	60
1.160.900.054	W 16.90, 115 VAC/a0	60
1.160.900.056	W 16.90, 230 VAC/a0	60
1.168.250.012	W 16.20.10, 12 VDC/0	58
1.168.250.013	W 16.20.10, 24 VDC/0	58

Order code	Type	Page
1.168.250.049	W 16.20.10, 12 VDC/05	58
1.168.250.050	W 16.20.10, 24 VDC/05	58
1.168.250.051	W 16.20.10, 24 VAC/a0	58
1.168.250.054	W 16.20.10, 115 VAC/a0	58
1.168.250.056	W 16.20.10, 230 VAC/a0	58
1.168.260.012	W 16.20.31, 12 VDC/0	59
1.168.260.013	W 16.20.31, 24 VDC/0	59
1.168.260.049	W 16.20.31, 12 VDC/05	59
1.168.260.050	W 16.20.31, 24 VDC/05	59
1.168.260.051	W 16.20.31, 24 VAC/a0	59
1.168.260.054	W 16.20.31, 115 VAC/a0	59
1.168.260.056	W 16.20.31, 230 VAC/a0	59
1.162.001.012	AW 16.00, 12 VDC/0	61
1.162.001.013	AW 16.00, 24 VDC/0	61
1.162.001.049	AW 16.00, 12 VDC/05	61
1.162.001.050	AW 16.00, 24 VDC/05	61
1.162.001.051	AW 16.00, 24 VAC/a0	61
1.162.001.054	AW 16.00, 115 VAC/a0	61
1.162.001.056	AW 16.00, 230 VAC/a0	61
1.162.800.012	AW 16.80, 12 VDC/0	61
1.162.800.013	AW 16.80, 24 VDC/0	61
1.162.810.012	AW 16.81, 12 VDC/0	61
1.162.810.013	AW 16.81, 24 VDC/0	61
1.740.500.XXX	W17.50, DC	59
1.740.500.XXX	W17.50, AC	59
1.740.800.XXX	W 17.80, DC	61
1.740.800.XXX	W 17.80, AC	61
1.740.701.XXX	W 17.90, DC	60
1.740.900.XXX	W 17.90, AC	60
1.742.800.XXX	AW 17.80, 12 DC	61
1.180.110.XXX	BK 14.11, DC	63
1.180.110.XXX	BK 14.11, AC	63
1.180.210.XXX	BK 14.21, DC	63
1.180.210.XXX	BK 14.21, AC	63
1.190.100.XXX	BK 16.10, DC	62
1.190.100.XXX	BK 16.10, AC	62
1.190.200.XXX	BK 16.20, DC	63
1.190.200.XXX	BK 16.20, AC	63
1.200.110.012	B 15.11, 12 VDC/0	69
1.200.110.013	B 15.11, 24 VDC/0	69
1.200.110.032	B 15.11, 12 VDC/I	69
1.200.110.033	B 15.11, 24 VDC/I	69
1.200.110.061	B 15.11, 24 VAC/a	69
1.200.110.064	B 15.11, 115 VAC/a	69
1.200.110.066	B 15.11, 230 VAC/a	69
1.200.210.012	B 15.21, 12 VDC/0	70
1.200.210.013	B 15.21, 24 VDC/0	70
1.200.210.032	B 15.21, 12 VDC/I	70
1.200.210.033	B 15.21, 24 VDC/I	70
1.200.210.061	B 15.21, 24 VAC/a	70
1.200.210.064	B 15.21, 115 VAC/a	70
1.200.210.066	B 15.21, 230 VAC/a	70
1.230.002.012	B 16.00, 12 VDC/0	65
1.230.002.013	B 16.00, 24 VDC/0	65
1.230.002.032	B 16.00, 12 VDC/I	65
1.230.002.033	B 16.00, 24 VDC/I	65
1.230.002.061	B 16.00, 24 VAC/a	65
1.230.002.064	B 16.00, 115 VAC/a	65
1.230.002.066	B 16.00, 230 VAC/a	65
1.230.012.012	B 16.01, 12 VDC/0	68
1.230.012.013	B 16.01, 24 VDC/0	68
1.230.012.032	B 16.01, 12 VDC/I	68

# Cross-reference Table Order Code – Type



Order code	Type	Page
1.230.012.033	B 16.01, 24 VDC/I	68
1.230.012.061	B 16.01, 24 VAC/a	68
1.230.012.064	B 16.01, 115 VAC/a	68
1.230.012.066	B 16.01, 230 VAC/a	68
1.230.100.012	B 16.10, 12 VDC/O	65
1.230.100.013	B 16.10, 24 VDC/O	65
1.230.100.032	B 16.10, 12 VDC/I	65
1.230.100.033	B 16.10, 24 VDC/I	65
1.230.100.061	B 16.10, 24 VAC/a	65
1.230.100.064	B 16.10, 115 VAC/a	65
1.230.100.066	B 16.10, 230 VAC/a	65
1.230.110.012	B 16.11, 12 VDC/O	69
1.230.110.013	B 16.11, 24 VDC/O	69
1.230.110.032	B 16.11, 12 VDC/I	69
1.230.110.033	B 16.11, 24 VDC/I	69
1.230.110.061	B 16.11, 24 VAC/a	69
1.230.110.064	B 16.11, 115 VAC/a	69
1.230.110.066	B 16.11, 230 VAC/a	69
1.230.200.012	B 16.20, 12 VDC/O	66
1.230.200.013	B 16.20, 24 VDC/O	66
1.230.200.032	B 16.20, 12 VDC/I	66
1.230.200.033	B 16.20, 24 VDC/I	66
1.230.200.061	B 16.20, 24 VAC/a	66
1.230.200.064	B 16.20, 115 VAC/a	66
1.230.200.066	B 16.20, 230 VAC/a	66
1.230.210.012	B 16.21, 12 VDC/O	70
1.230.210.013	B 16.21, 24 VDC/O	70
1.230.210.032	B 16.21, 12 VDC/I	70
1.230.210.033	B 16.21, 24 VDC/I	70
1.230.210.061	B 16.21, 24 VAC/a	70
1.230.210.064	B 16.21, 115 VAC/a	70
1.230.210.066	B 16.21, 230 VAC/a	70
1.230.300.012	B 16.30, 12 VDC/O	67
1.230.300.013	B 16.30, 24 VDC/O	67
1.230.300.032	B 16.30, 12 VDC/I	67
1.230.300.033	B 16.30, 24 VDC/I	67
1.230.300.061	B 16.30, 24 VAC/a	67
1.230.300.064	B 16.30, 115 VAC/a	67
1.230.300.066	B 16.30, 230 VAC/a	67
1.230.310.012	B 16.31, 12 VDC/O	71
1.230.310.013	B 16.31, 24 VDC/O	71
1.230.310.032	B 16.31, 12 VDC/I	71
1.230.310.033	B 16.31, 24 VDC/I	71
1.230.310.061	B 16.31, 24 VAC/a	71
1.230.310.064	B 16.31, 115 VAC/a	71
1.230.310.066	B 16.31, 230 VAC/a	71
1.231.502.012	F1B 16.00, 12 VDC/O	67
1.231.502.013	F1B 16.00, 24 VDC/O	67
1.231.502.032	F1B 16.00, 12 VDC/I	67
1.231.502.033	F1B 16.00, 24 VDC/I	67
1.231.502.061	F1B 16.00, 24 VAC/a	67
1.231.502.064	F1B 16.00, 115 VAC/a	67
1.231.502.066	F1B 16.00, 230 VAC/a	67
1.231.512.012	F1B 16.01, 12 VDC/O	71
1.231.512.013	F1B 16.01, 24 VDC/O	71
1.231.512.032	F1B 16.01, 12 VDC/I	71
1.231.512.033	F1B 16.01, 24 VDC/I	71
1.231.512.061	F1B 16.01, 24 VAC/a	71
1.231.512.064	F1B 16.01, 115 VAC/a	71
1.231.512.066	F1B 16.01, 230 VAC/a	71
1.260.002.012	B 18.00, 12 VDC/O	65
1.260.002.013	B 18.00, 24 VDC/O	65

Order code	Type	Page
1.260.002.032	B 18.00, 12 VDC/I	65
1.260.002.033	B 18.00, 24 VDC/I	65
1.260.002.061	B 18.00, 24 VAC/a	65
1.260.002.064	B 18.00, 115 VAC/a	65
1.260.002.066	B 18.00, 230 VAC/a	65
1.260.100.012	B 18.10, 12 VDC/O	66
1.260.100.013	B 18.10, 24 VDC/O	66
1.260.100.032	B 18.10, 12 VDC/I	66
1.260.100.033	B 18.10, 24 VDC/I	66
1.260.100.061	B 18.10, 24 VAC/a	66
1.260.100.064	B 18.10, 115 VAC/a	66
1.260.100.066	B 18.10, 230 VAC/a	66
1.260.200.012	B 18.20, 12 VDC/O	66
1.260.200.013	B 18.20, 24 VDC/O	66
1.260.200.032	B 18.20, 12 VDC/I	66
1.260.200.033	B 18.20, 24 VDC/I	66
1.260.200.061	B 18.20, 24 VAC/a	66
1.260.200.064	B 18.20, 115 VAC/a	66
1.260.200.066	B 18.20, 230 VAC/a	66
1.260.300.012	B 18.30, 12 VDC/O	67
1.260.300.013	B 18.30, 24 VDC/O	67
1.260.300.032	B 18.30, 12 VDC/I	67
1.260.300.033	B 18.30, 24 VDC/I	67
1.260.300.061	B 18.30, 24 VAC/a	67
1.260.300.064	B 18.30, 115 VAC/a	67
1.260.300.066	B 18.30, 230 VAC/a	67
1.261.502.012	F1B 18.00, 12 VDC/O	68
1.261.502.013	F1B 18.00, 24 VDC/O	68
1.261.502.032	F1B 18.00, 12 VDC/I	68
1.261.502.033	F1B 18.00, 24 VDC/I	68
1.261.502.061	F1B 18.00, 24 VAC/a	68
1.261.502.064	F1B 18.00, 115 VAC/a	68
1.261.502.066	F1B 18.00, 230 VAC/a	68
1.310.110.XXX	MK 14.11, DC	74
1.310.110.XXX	MK 14.11, AC	74
1.310.210.XXX	MK 14.21, DC	74
1.310.210.XXX	MK 14.21, AC	74
1.330.200.XXX	MK 16.20, DC	73
1.330.200.XXX	MK 16.20, AC	73
1.340.110.XXX	MK 16.11, DC	74
1.340.110.XXX	MK 16.11, AC	74
1.340.210.XXX	MK 16.21, DC	75
1.340.210.XXX	MK 16.21, AC	75
1.340.230.XXX	MK 16.23, DC	75
1.340.230.XXX	MK 16.23, AC	75
1.360.100.XXX	MK 18.10, DC	73
1.360.100.XXX	MK 18.10, AC	73
1.360.200.XXX	MK 18.20, DC	73
1.360.200.XXX	MK 18.20, AC	73
1.520.XXX.XXX	E 16	77
1.650.200.002	K 66.20, 1.5 VDC/O	41
1.650.200.006	K 66.20, 3 VDC/O	41
1.650.200.008	K 66.20, 4.5 VDC/O	41
1.650.200.009	K 66.20, 5 VDC/O	41
1.650.200.010	K 66.20, 6 VDC/O	41
1.650.200.012	K 66.20, 12 VDC/O	41
1.650.200.013	K 66.20, 24 VDC/O	41
1.650.800.002	K 66.80, 1.5 VDC/O	41
1.650.800.006	K 66.80, 3 VDC/O	41
1.650.800.008	K 66.80, 4.5 VDC/O	41
1.650.800.009	K 66.80, 5 VDC/O	41
1.650.800.010	K 66.80, 6 VDC/O	41

# Cross-reference Table Order Code – Type



Order code	Type	Page
1.650.800.012	K 66.80, 12 VDC/0	41
1.650.800.013	K 66.80, 24 VDC/0	41
1.650.900.002	K 66.90, 1.5 VDC/0	41
1.650.900.006	K 66.90, 3 VDC/0	41
1.650.900.008	K 66.90, 4.5 VDC/0	41
1.650.900.009	K 66.90, 5 VDC/0	41
1.650.900.010	K 66.90, 6 VDC/0	41
1.650.900.012	K 66.90, 12 VDC/0	41
1.650.900.013	K 66.90, 24 VDC/0	41
1.650.910.002	K 66.91, 1.5 VDC/0	42
1.650.910.006	K 66.91, 3 VDC/0	42
1.650.910.008	K 66.91, 4.5 VDC/0	42
1.650.910.009	K 66.91, 5 VDC/0	42
1.650.910.010	K 66.91, 6 VDC/0	42
1.650.910.012	K 66.91, 12 VDC/0	42
1.650.910.013	K 66.91, 24 VDC/0	42
1.650.940.002	K 66.94, 1.5 VDC/0	42
1.650.940.006	K 66.94, 3 VDC/0	42
1.650.940.008	K 66.94, 4.5 VDC/0	42
1.650.940.009	K 66.94, 5 VDC/0	42
1.650.940.010	K 66.94, 6 VDC/0	42
1.650.940.012	K 66.94, 12 VDC/0	42
1.650.940.013	K 66.94, 24 VDC/0	42
1.650.950.002	K 66.95, 1.5 VDC/0	43
1.650.950.006	K 66.95, 3 VDC/0	43
1.650.950.008	K 66.95, 4.5 VDC/0	43
1.650.950.009	K 66.95, 5 VDC/0	43
1.650.950.010	K 66.95, 6 VDC/0	43
1.650.950.012	K 66.95, 12 VDC/0	43
1.650.950.013	K 66.95, 24 VDC	43
1.660.200.002	K 67.20, 1.5 VDC/0	41
1.660.200.006	K 67.20, 3 VDC/0	41
1.660.200.008	K 67.20, 4.5 VDC/0	41
1.660.200.009	K 67.20, 5 VDC/0	41
1.660.200.010	K 67.20, 6 VDC/0	41
1.660.200.012	K 67.20, 12 VDC/0	41
1.660.200.013	K 67.20, 24 VDC/0	41
1.660.800.002	K 67.80, 1.5 VDC/0	41
1.660.800.006	K 67.80, 3 VDC/0	41
1.660.800.008	K 67.80, 4.5 VDC/0	41
1.660.800.009	K 67.80, 5 VDC/0	41
1.660.800.010	K 67.80, 6 VDC/0	41
1.660.800.012	K 67.80, 12 VDC/0	41
1.660.800.013	K 67.80, 24 VDC/0	41
1.660.900.002	K 67.90, 1.5 VDC/0	41
1.660.900.006	K 67.90, 3 VDC/0	41
1.660.900.008	K 67.90, 4.5 VDC/0	41
1.660.900.009	K 67.90, 5 VDC/0	41
1.660.900.010	K 67.90, 6 VDC/0	41
1.660.900.012	K 67.90, 12 VDC/0	41
1.660.900.013	K 67.90, 24 VDC/0	41
1.660.910.002	K 67.91, 1.5 VDC/0	42
1.660.910.006	K 67.91, 3 VDC/0	42
1.660.910.008	K 67.91, 4.5 VDC/0	42
1.660.910.009	K 67.91, 5 VDC/0	42
1.660.910.010	K 67.91, 6 VDC/0	42
1.660.910.012	K 67.91, 12 VDC/0	42
1.660.910.013	K 67.91, 24 VDC/0	42
1.700.200.002	K 46.20, 1.5 VDC/0	36
1.700.200.006	K 46.20, 3 VDC/0	36
1.700.200.008	K 46.20, 4.5 VDC/0	36
1.700.200.009	K 46.20, 5 VDC/0	36

Order code	Type	Page
1.700.200.010	K 46.20, 6 VDC/0	36
1.700.200.012	K 46.20, 12 VDC/0	36
1.700.200.013	K 46.20, 24 VDC/0	36
1.700.800.002	K 46.80, 1.5 VDC/0	37
1.700.800.006	K 46.80, 3 VDC/0	37
1.700.800.008	K 46.80, 4.5 VDC/0	37
1.700.800.009	K 46.80, 5 VDC/0	37
1.700.800.010	K 46.80, 6 VDC/0	37
1.700.800.012	K 46.80, 12 VDC/0	37
1.700.800.013	K 46.80, 24 VDC/0	37
1.700.900.002	K 46.90, 1.5 VDC/0	37
1.700.900.006	K 46.90, 3 VDC/0	37
1.700.900.008	K 46.90, 4.5 VDC/0	37
1.700.900.009	K 46.90, 5 VDC/0	37
1.700.900.010	K 46.90, 6 VDC/0	37
1.700.900.012	K 46.90, 12 VDC/0	37
1.700.900.013	K 46.90, 24 VDC/0	37
1.700.910.002	K 46.91, 1.5 VDC/0	38
1.700.910.006	K 46.91, 3 VDC/0	38
1.700.910.008	K 46.91, 4.5 VDC/0	38
1.700.910.009	K 46.91, 5 VDC/0	38
1.700.910.010	K 46.91, 6 VDC/0	38
1.700.910.012	K 46.91, 12 VDC/0	38
1.700.910.013	K 46.91, 24 VDC/0	38
1.700.940.002	K 46.94, 1.5 VDC/0	38
1.700.940.006	K 46.94, 3 VDC/0	38
1.700.940.008	K 46.94, 4.5 VDC/0	38
1.700.940.009	K 46.94, 5 VDC/0	38
1.700.940.010	K 46.94, 6 VDC/0	38
1.700.940.012	K 46.94, 12 VDC/0	38
1.700.940.013	K 46.94, 24 VDC/0	38
1.700.950.002	K 46.95, 1.5 VDC/0	39
1.700.950.006	K 46.95, 3 VDC/0	39
1.700.950.008	K 46.95, 4.5 VDC/0	39
1.700.950.009	K 46.95, 5 VDC/0	39
1.700.950.010	K 46.95, 6 VDC/0	39
1.700.950.012	K 46.95, 12 VDC/0	39
1.700.950.013	K 46.95, 24 VDC/0	39
1.710.200.002	K 47.20, 1.5 VDC/0	36
1.710.200.006	K 47.20, 3 VDC/0	36
1.710.200.008	K 47.20, 4.5 VDC/0	36
1.710.200.009	K 47.20, 5 VDC/0	36
1.710.200.010	K 47.20, 6 VDC/0	36
1.710.200.012	K 47.20, 12 VDC/0	36
1.710.200.013	K 47.20, 24 VDC/0	36
1.710.800.002	K 47.80, 1.5 VDC/0	37
1.710.800.006	K 47.80, 3 VDC/0	37
1.710.800.008	K 47.80, 4.5 VDC/0	37
1.710.800.009	K 47.80, 5 VDC/0	37
1.710.800.010	K 47.80, 6 VDC/0	37
1.710.800.012	K 47.80, 12 VDC/0	37
1.710.800.013	K 47.80, 24 VDC/0	37
1.710.900.002	K 47.90, 1.5 VDC/0	37
1.710.900.006	K 47.90, 3 VDC/0	37
1.710.900.008	K 47.90, 4.5 VDC/0	37
1.710.900.009	K 47.90, 5 VDC/0	37
1.710.900.010	K 47.90, 6 VDC/0	37
1.710.900.012	K 47.90, 12 VDC/0	37
1.710.900.013	K 47.90, 24 VDC/0	37
1.710.910.002	K 47.91, 1.5 VDC/0	38
1.710.910.006	K 47.91, 3 VDC/0	38
1.710.910.008	K 47.91, 4.5 VDC/0	38

# Cross-reference Table Order Code – Type



Order code	Type	Page
1.710.910.009	K 47.91, 5 VDC/0	38
1.710.910.010	K 47.91, 6 VDC/0	38
1.710.910.012	K 47.91, 12 VDC/0	38
1.710.910.013	K 47.91, 24 VDC/0	38
1.944.X00.XXX	KWH 17	82
1.944.X01.XXX	KWH 17	82
2.100.011.033	BVa 15.01, 24 VDC/I	146
2.100.011.061	BVa 15.01, 24 VAC/a	146
2.100.011.064	BVa 15.01, 115 VAC/a	146
2.100.011.066	BVa 15.01, 230 VAC/a	146
2.100.110.033	BVa 15.11, 24 VDC/I	146
2.100.110.061	BVa 15.11, 24 VAC/a	146
2.100.110.064	BVa 15.11, 115 VAC/a	146
2.100.110.066	BVa 15.11, 230 VAC/a	146
2.100.210.033	BVa 15.21, 24 VDC/I	147
2.100.210.061	BVa 15.21, 24 VAC/a	147
2.100.210.064	BVa 15.21, 115 VAC/a	147
2.100.210.066	BVa 15.21, 230 VAC/a	147
2.100.310.033	BVa 15.31, 24 VDC/I	147
2.100.310.061	BVa 15.31, 24 VAC/a	147
2.100.310.064	BVa 15.31, 115 VAC/a	147
2.100.310.066	BVa 15.31, 230 VAC/a	147
2.120.011.033	BVa 15.01/3, 24 VDC/I	146
2.120.011.061	BVa 15.01/3, 24 VAC/a	146
2.120.011.064	BVa 15.01/3, 115 VAC/a	146
2.120.011.066	BVa 15.01/3, 230 VAC/a	146
2.120.110.033	BVa 15.11/3, 24 VDC/I	146
2.120.110.061	BVa 15.11/3, 24 VAC/a	146
2.120.110.064	BVa 15.11/3, 115 VAC/a	146
2.120.110.066	BVa 15.11/3, 230 VAC/a	146
2.120.210.033	BVa 15.21/3, 24 VDC/I	147
2.120.210.061	BVa 15.21/3, 24 VAC/a	147
2.120.210.064	BVa 15.21/3, 115 VAC/a	147
2.120.210.066	BVa 15.21/3, 230 VAC/a	147
2.120.310.033	BVa 15.31/3, 24 VDC/I	147
2.120.310.061	BVa 15.31/3, 24 VAC/a	147
2.120.310.064	BVa 15.31/3, 115 VAC/a	147
2.120.310.066	BVa 15.31/3, 230 VAC/a	147
2.300.110.033	MVs 13.11, 24 VDC/I	150
2.300.110.061	MVs 13.11, 24 VAC/a	150
2.300.110.064	MVs 13.11, 115 VAC/a	150
2.300.110.066	MVs 13.11, 230 VAC/a	150
2.300.130.033	MVs 13.13, 24 VDC/I	151
2.300.130.061	MVs 13.13, 24 VAC/a	151
2.300.130.064	MVs 13.13, 115 VAC/a	151
2.300.130.066	MVs 13.13, 230 VAC/a	151
2.300.210.033	MVs 13.21, 24 VDC/I	150
2.300.210.061	MVs 13.21, 24 VAC/a	150
2.300.210.064	MVs 13.21, 115 VAC/a	150
2.300.210.066	MVs 13.21, 230 VAC/a	150
2.300.230.033	MVs 13.23, 24 VDC/I	151
2.300.230.061	MVs 13.23, 24 VAC/a	151
2.300.230.064	MVs 13.23, 115 VAC/a	151
2.300.230.066	MVs 13.23, 230 VAC/a	151
2.310.110.033	MVs 13.11/2, 24 VDC/I	150
2.310.110.061	MVs 13.11/2, 24 VAC/a	150
2.310.110.064	MVs 13.11/2, 115 VAC/a	150
2.310.110.066	MVs 13.11/2, 230 VAC/a	150
2.310.130.033	MVs 13.13/2, 24 VDC/I	151
2.310.130.061	MVs 13.13/2, 24 VAC/a	151
2.310.130.064	MVs 13.13/2, 115 VAC/a	151
2.310.130.066	MVs 13.13/2, 230 VAC/a	151

Order code	Type	Page
2.310.210.033	MVs 13.21/2, 24 VDC/I	150
2.310.210.061	MVs 13.21/2, 24 VAC/a	150
2.310.210.064	MVs 13.21/2, 115 VAC/a	150
2.310.210.066	MVs 13.21/2, 230 VAC/a	150
2.310.230.033	MVs 13.23/2, 24 VDC/I	151
2.310.230.061	MVs 13.23/2, 24 VAC/a	151
2.310.230.064	MVs 13.23/2, 115 VAC/a	151
2.310.230.066	MVs 13.23/2, 230 VAC/a	151
2.320.030.033	MVs 16.03, 24 VDC/I	154
2.320.030.061	MVs 16.03, 24 VAC/a	154
2.320.030.064	MVs 16.03, 115 VAC/a	154
2.320.030.066	MVs 16.03, 230 VAC/a	154
2.320.110.033	MVs 16.11, 24 VDC/I	153
2.320.110.061	MVs 16.11, 24 VAC/a	153
2.320.110.064	MVs 16.11, 115 VAC/a	153
2.320.110.066	MVs 16.11, 230 VAC/a	153
2.320.210.033	MVs 16.21, 24 VDC/I	153
2.320.210.061	MVs 16.21, 24 VAC/a	153
2.320.210.064	MVs 16.21, 115 VAC/a	153
2.320.210.066	MVs 16.21, 230 VAC/a	153
2.320.230.033	MVs 16.23, 24 VDC/I	154
2.320.230.061	MVs 16.23, 24 VAC/a	154
2.320.230.064	MVs 16.23, 115 VAC/a	154
2.320.230.066	MVs 16.23, 230 VAC/a	154
3.050.2XX.383	HK46.20, 4.5 - 35 VDC	158
3.050.8XX.383	HK46.80, 4.5 - 35 VDC	158
3.060.2XX.383	HK47.20, 4.5 - 35 VDC	158
3.060.8XX.383	HK47.80, 4.5 - 35 VDC	158
3.100.000.383	AHK 07.00, 4.5 - 35 VDC	161
3.100.200.383	HK 07.20, 4.5 - 35 VDC	159
3.100.401.383	HK 07.40, 4.5 - 35 VDC	160
3.100.500.383	HK 07.50, 4.5 - 35 VDC	160
3.100.800.383	HK 07.80, 4.5 - 35 VDC	162
3.100.900.383	HK 07.90, 4.5 - 35 VDC	161
3.100.910.383	HK 07.91, 4.5 - 35 VDC	160
3.100.920.383	HK 07.92, 4.5 - 35 VDC	161
3.104.401.383	HK 07.40 D, 4.5 - 35 VDC	163
3.104.500.383	HK 07.50 D, 4.5 - 35 VDC	164
3.104.900.383	HK 07.90 D, 4.5 - 35 VDC	164
3.104.910.383	HK 07.91 D, 4.5 - 35 VDC	164
3.102.101.XXX	SHK 07.1, AC/DC	165
3.130.051.XXX	HK 17.051.39, AC/DC	168
3.130.151.XXX	HK 17.151.39, AC/DC	167
3.130.251.XXX	HK 17.251.39, AC/DC	167
3.130.251.XXX.056	HK 17.251.56, AC/DC	168
3.130.451.XXX	HK 17.451.39, AC/DC	167
3.130.511.XXX	HK 17.511, AC/DC	169
3.130.611.XXX	HK 17.611, AC/DC	169
3.160.111.XXX	HB 26.11, DC	180
3.160.111.XXX	HB 26.11, AC	180
3.160.211.XXX	HB 26.21, DC	181
3.160.211.XXX	HB 26.21, AC	181
3.160.311.XXX	HB 26.31, DC	181
3.160.311.XXX	HB 26.31, AC	181
3.160.611.XXX	K1HB 26.31, DC	182
3.160.611.XXX	K1HB 26.31, AC	182
3.160.711.XXX	DvHB 26.31, DC	182
3.160.711.XXX	DvHB 26.31, AC	182
3.160.811.XXX	DvsHB 26.31, DC	182
3.160.811.XXX	DvsHB 26.31, AC	182
3.165.011.XXX	HB 26.01.3, DC	181
3.165.011.XXX	HB 26.01.3, AC	181

# Cross-reference Table Order Code – Type



Order code	Type	Page
3.200.XXX.XXX	HB 27.XX, DC	183-184
3.200.XXX.XXX	HB 27.XX, AC	183-184
3.220.401.XXX	H 57, DC	175
3.220.401.XXX	H 57, AC	175
3.221.401.XXX	H 57.55, DC	175
3.221.401.XXX	H 57.55, AC	175
3.222.401.XXX	H 57.72, DC	175
3.222.401.XXX	H 57.72, AC	175
3.223.401.XXX	AH 57, DC	176
3.223.401.XXX	AH 57, AC	176
3.22S.401.XXX	H 57S, DC	178
3.22S.401.XXX	H 57S, AC	178
3.240.XXX.XXX	H 37, DC	170
3.240.XXX.XXX	H 37, AC	170
3.241.XXX.XXX	H 37.1, DC	171
3.241.XXX.XXX	H 37.1, AC	171
3.242.XXX.XXX	H 37.2, DC	171
3.242.XXX.XXX	H 37.2, AC	171
3.244.XXX.XXX	H 37.4, DC	171
3.244.XXX.XXX	H 37.4, AC	161
3.245.201.XXX	H 37.5, 10-30 VDC	172
3.245.201.XXX	H 37.5, 187-264 VAC	172
3.24S.XXX.XXX	H 37S, DC	174
3.24S.XXX.XXX	H 37S, AC	174
3.300.XXX.XXX	HVa 15.X1, DC	225-226-227
3.300.XXX.XXX	HVa 15.X1, AC	225-226-227
3.550.401.XXX	HC 77, DC	84-187
3.550.401.XXX	HC 77, AC	84-187
3.551.401.XXX	HC 77.55, DC	84-187
3.551.401.XXX	HC 77.55, AC	84-187
3.552.401.XXX	HC 77.72, DC	84-187
3.552.401.XXX	HC 77.72, AC	84-187
3.553.401.XXX	SHC 77, DC	85-188
3.553.401.XXX	SHC 77, AC	85-188
3.553.401.XXX.060	SHC 77.60, DC	85-188
3.553.401.XXX.060	SHC 77.60, AC	85-188
3.563.201.074	HW 66, 115 VAC	86-189
3.563.201.075	HW 66, 230 VAC	86-189
3.802.X10	PMK 14.X1, grey	78-79
3.802.X11	PMK 14.X1, black	78-79
3.804.X10	PMK 16.X1, grey	79
3.804.X11	PMK 16.X1, black	79
3.805.X00	PMK 18.X0, grey	80
3.805.X01	PMK 18.X0, black	80
6.190.012.XXX	190	116
6.192.012.300	192	117
6.194.012.XXX	194	194
6.198.012.300	198	195
6.130.012.850	CODIX 130	89
6.130.012.852	CODIX 130	89
6.130.012.853	CODIX 130	89
6.130.012.860	CODIX 130	89
6.130.012.862	CODIX 130	89
6.130.012.863	CODIX 130	89
6.131.012.850	CODIX 131	91
6.131.012.851	CODIX 131	91
6.131.012.853	CODIX 131	91
6.131.012.860	CODIX 131	91
6.131.012.861	CODIX 131	91
6.131.012.863	CODIX 131	91

Order code	Type	Page
6.132.012.853	CODIX 132	93
6.132.012.863	CODIX 132	93
6.133.012.850	CODIX 133	95-267
6.133.012.851	CODIX 133	95-267
6.133.012.860	CODIX 133	95-267
6.133.012.861	CODIX 133	95-267
6.134.012.850	CODIX 134	191
6.134.012.851	CODIX 134	191
6.134.012.853	CODIX 134	180
6.134.012.860	CODIX 134	191
6.134.012.861	CODIX 134	191
6.134.012.863	CODIX 134	191
6.135.012.850	CODIX 135	191
6.135.012.851	CODIX 135	193
6.135.012.853	CODIX 135	193
6.135.012.860	CODIX 135	193
6.135.012.861	CODIX 135	193
6.135.012.863	CODIX 135	193
6.136.012.850	CODIX 136	231
6.136.012.851	CODIX 136	231
6.136.012.860	CODIX 136	231
6.136.012.861	CODIX 136	231
6.520.012.300	CODIX 520	97
6.521.011.300	CODIX 521	99-269
6.521.012.300	CODIX 521	99-269
6.522.011.300	CODIX 522	233
6.522.012.300	CODIX 522	233
6.523.011.300	CODIX 523	197
6.523.012.300	CODIX 523	197
6.524.011.300	CODIX 524	101-199-235-271
6.524.012.300	CODIX 524	101-199-235-271
6.52U.012.300	CODIX 52U	103-201-237
6.52P.012.300	CODIX 52P	100-222-252
6.540.012.X00	CODIX 540	107
6.541.011.X00	CODIX 541	109-275
6.541.012.X00	CODIX 541	109-275
6.542.011.X00	CODIX 542	241
6.542.012.X00	CODIX 542	241
6.543.011.X00	CODIX 543	203
6.543.012.X00	CODIX 543	203
6.544.011.X00	CODIX 544	111-205-243-277
6.544.012.X00	CODIX 544	111-205-243-277
6.54U.012.X00	CODIX 54U	113-207-245
6.54P.012.X00	CODIX 54P	115-247-279
6.715.010.000	715	139-219-259
6.715.010.100	715	139-219-259
6.715.010.300	715	139-219-259
6.715.011.000	715	139-219-259
6.715.011.100	715	139-219-259



## Cross-reference Table Order Code – Type

Order code	Type	Page
6.715.011.300	715	139-219-259
6.716.01X.000	Type 716/717 and 717 EX	143-223-263
6.716.01X.005	Type 716/717 and 717 EX	143-223-263
6.716.01X.006	Type 716/717 and 717 EX	143-223-263
6.716.01X.007	Type 716/717 and 717 EX	143-223-263
6.716.01X.300	Type 716/717 and 717 EX	143-223-263
6.716.01X.305	Type 716/717 and 717 EX	143-223-263
6.716.01X.306	Type 716/717 and 717 EX	143-223-263
6.716.01X.307	Type 716/717 and 717 EX	143-223-263
6.717.01X.000	Type 716/717 and 717 EX	143-223-263
6.717.01X.005	Type 716/717 and 717 EX	143-223-263
6.717.01X.006	Type 716/717 and 717 EX	143-223-263
6.717.01X.007	Type 716/717 and 717 EX	143-223-263
6.717.01X.300	Type 716/717 and 717 EX	143-223-263
6.717.01X.305	Type 716/717 and 717 EX	143-223-263
6.717.01X.306	Type 716/717 and 717 EX	143-223-263
6.717.01X.307	Type 716/717 and 717 EX	143-223-263
6.717.010.X00Ex	Type 716/717 and 717 EX	143-223-263
6.901.010.800	901	127
6.903.010.000	903	136-216-256
6.903.010.300	903	136-216-256
6.903.011.000	903	136-215-256
6.903.011.300	903	135-216-256
6.904.010.000	904	136-216-256
6.904.010.300	904	136-216-256
6.904.011.000	904	136-216-256
6.904.011.300	904	136-216-256
6.903.010.010	903	136-216-256
6.903.010.310	903	136-216-256
6.903.011.010	903	136-216-256
6.903.011.310	903	136-216-256

Order code	Type	Page
6.904.010.010	904	136-216-256
6.904.010.310	904	136-216-256
6.904.011.010	904	136-216-256
6.904.011.310	904	136-216-256
6.923.01XX.0X0	923/924	129-209-249-281
6.923.01XX.3X0	923/924	129-209-249-281
6.924.01XX.000	923/924	129-209-249-281
6.924.01XX.300	923/924	129-209-249-281
G.003.836		303
G.007.501	Front bezel F1B, beige	295
G.007.502	Front bezel F1B, black	295
G.007.503	Front bezel F2B, beige	299
G.007.504	Front bezel F2B, black	299
G.007.505	Front bezel F3B, aluminium-coloured	303
G.007.506	Front bezel F3B, black	303
G.007.507	Front bezel F3B, beige	303
G.007.508	Front bezel F4B, aluminium-coloured	303
G.007.509	Front bezel F4B, black	303
G.007.510	Front bezel F4B, beige	303
G.008.040	Add-on socket No. 48, black	306
G.008.041	Add-on socket No. 48, grey	306
G.008.121	Sealing cover, lockable above 1 Dv	297
G.008.141	Sealing cover, Typ 2 Dv	301
G.008.143	Sealing cover, lockable	302
G.008.151	Sealing cover, with key-lock Type 2 Dvs	301
G.008.153	Sealing cover, with key-lock	302
G.008.300	Sealing cover K1, grey	296
G.008.301	Flexible sealing cover K1	296
G.008.301	Sealing cover K1, black	296
G.008.302	Sealing cover K2, grey	300
G.008.303	Sealing cover K2, black	300
G.008.310	Sealing cover, Typ KV 3, grey	301
G.008.311	Sealing cover, Typ KV 3, black	301
G.008.433	Socket box 926.1	300
G.008.434	Socket box 945.2	296
G.008.439	Socket box 946.1	300
G.300.000	Rail mount frame SR 1	305
G.300.001	Rail mount frame SR 2	305
G.300.002	Rail mount frame SR 3	305
G.300.003	Rail mount frame for 35 mm DIN-rail, cut-out 48 x 48 mm	304
G.300.004	Rail mount enclosure for 35 mm DIN-rail, cut-out 25 x 50 mm	304
162704	Bezel adapter for cut-out 68 x 33 mm	294
N.003.001	Bezel adapter for cut-out 29 x 55 mm	295
N.003.002	Sealing cover, lockable below 1 Dv	296
N.008.131	Sealing cover, with key-lock 1 Dvs	297
N.140.076	RS 232 interface cable to the counter	293

## Cross-reference Table Order Code – Type



Order code	Type	Page
N.150.080	EzControl Software on CD	293
N.150.002	RS232 <=> RS485/422 interface converter with power supply and cable to the counter	293
N.150.003	RS232 <=> RS485/422 interface converter – US version – with power supply and cable to the counter	293
N.510.226	Slip-on bezel for bore ø 60	299
N.511.011	Sealing gasket HK 17.151 (31 x 40)	306
N.511.018	Sealing gasket 48 x 48 für z.B. H57	306
N.511.015	Sealing gasket H 37.2 (53 x 29)	306
N.511.016	Sealing gasket 72 x 72 for e. g. H57	306
N.511.017	Sealing gasket 55 x 55 for e. g. H57	306
N.511.003	Sealing gasket F2D	306
N.511.004	Sealing gasket Dv/Dvs	306
N.511.005	Sealing gasket F1D	306
N.511.006	Sealing gasket Dv/Dvs narrow	306
N.511.007	Sealing gasket AMK16	306
N.511.010	Sealing gasket ALMK16	306
N.511.011	Sealing gasket MK/HK	306
N.511.033	Sealing gasket 715, 901..904	306
N.511.034	Sealing gasket 520 ...529	306
T.005.752	Enclosure, blind 25 x 50mm, grey	303
T.005.753	Enclosure, blind 25 x 50mm, black	303
T.008.105	Front bezel F2M, grey	299
T.008.106	Front bezel F2M, black	299
T.008.160	Slip-on bezel 37.1, grey	294
T.008.161	Slip-on bezel 37.1, black	294
T.008.164	Slip-on bezel 37.2, grey	294
T.008.165	Slip-on bezel 37.2, black	294
T.008.170	Slip-on bezel 55, grey	297
T.008.171	Slip-on bezel 55, black	297
T.008.176	Slip-on bezel 72, grey	298
T.008.177	Slip-on bezel 72, black	298
T.008.180	Bezel adapter from 22 x 45 mm to 25 x 50 mm	294
T.008.853	Slip-on bezel 55	298
T.008.860	Bezel adapter 45	298
T.008.883	Sealing cover	295
T.009.420	Slip on bezel 72, arrester	298
T.051.687	Terminal cover KA 37	305





**Notes**

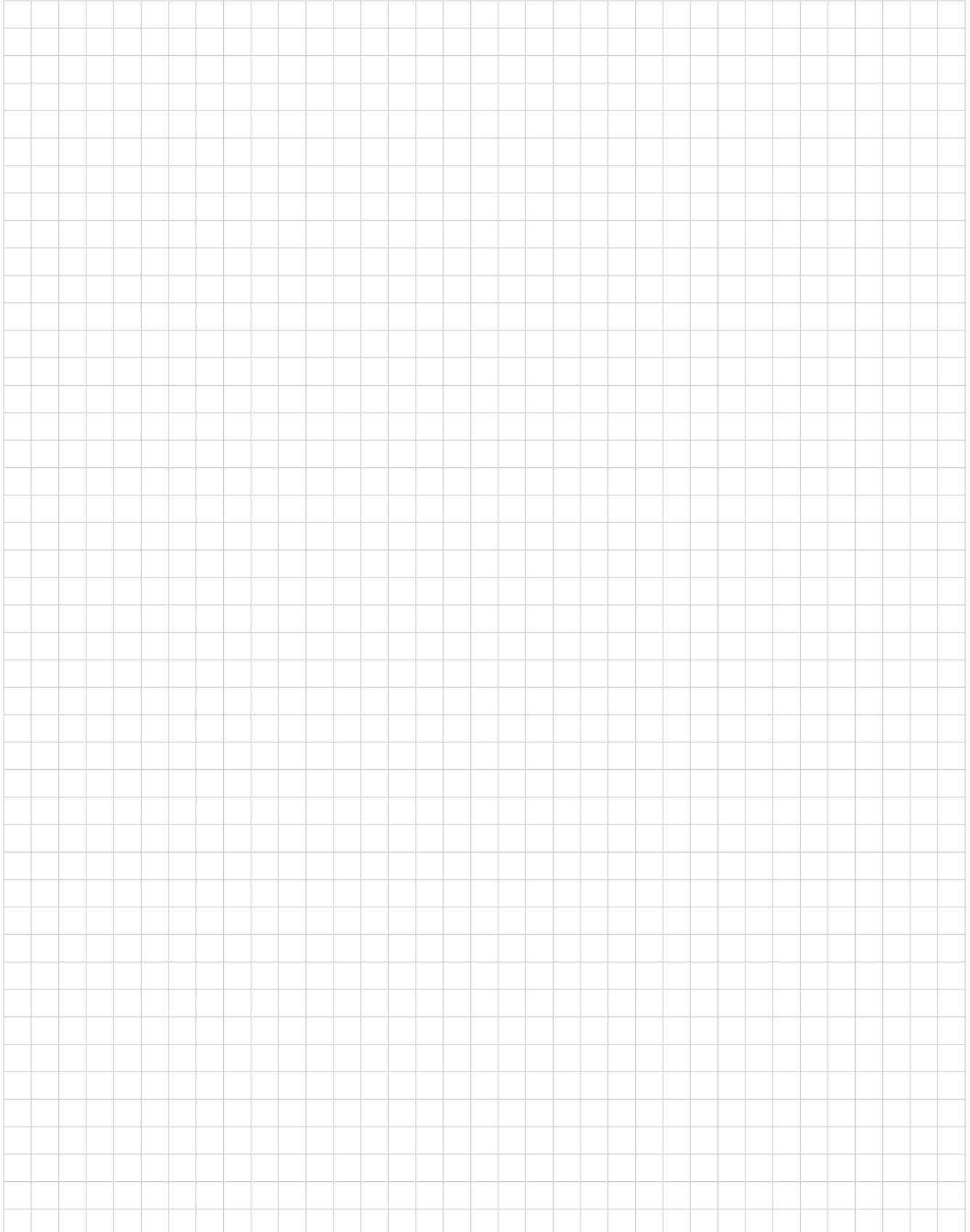

**Notes**

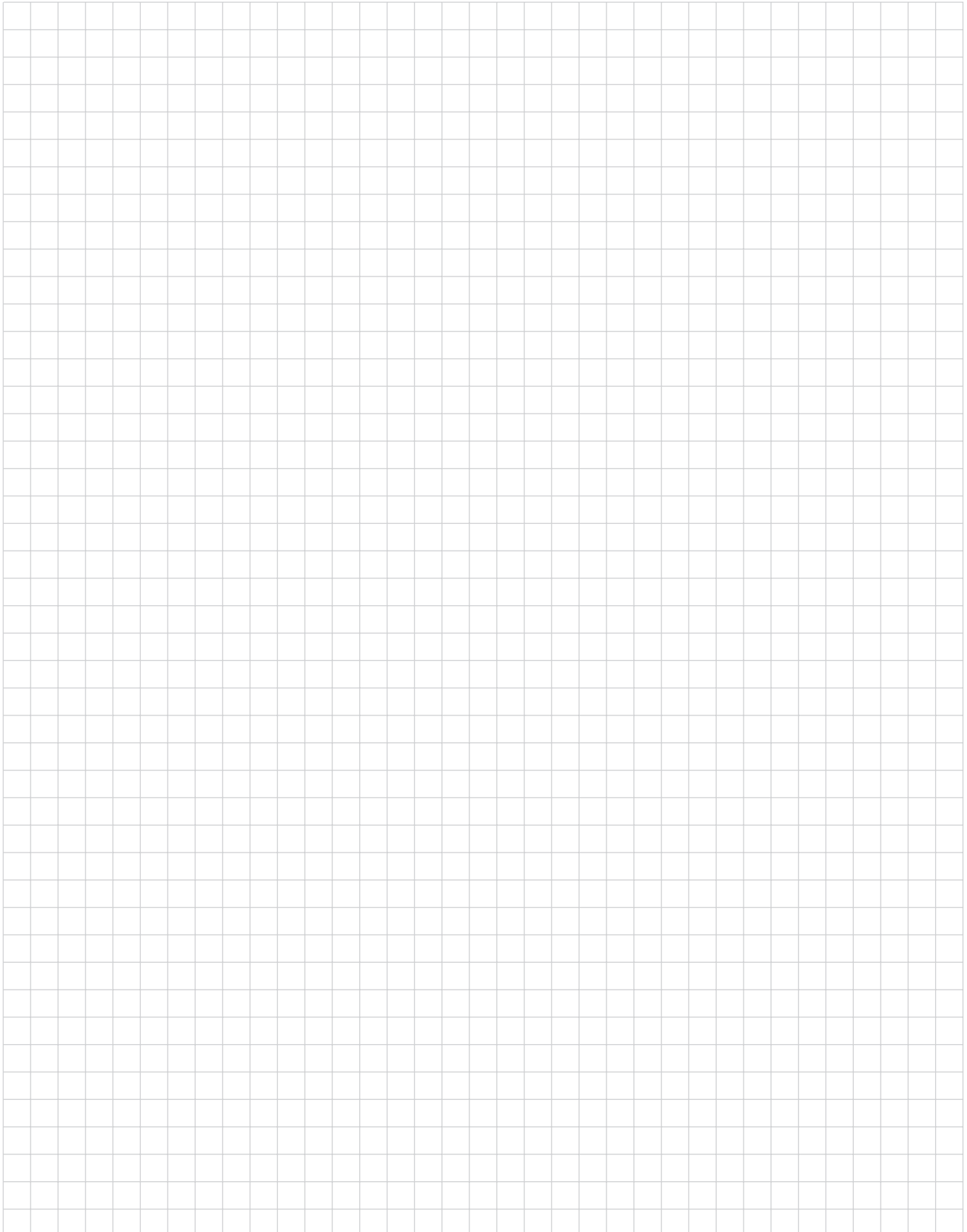

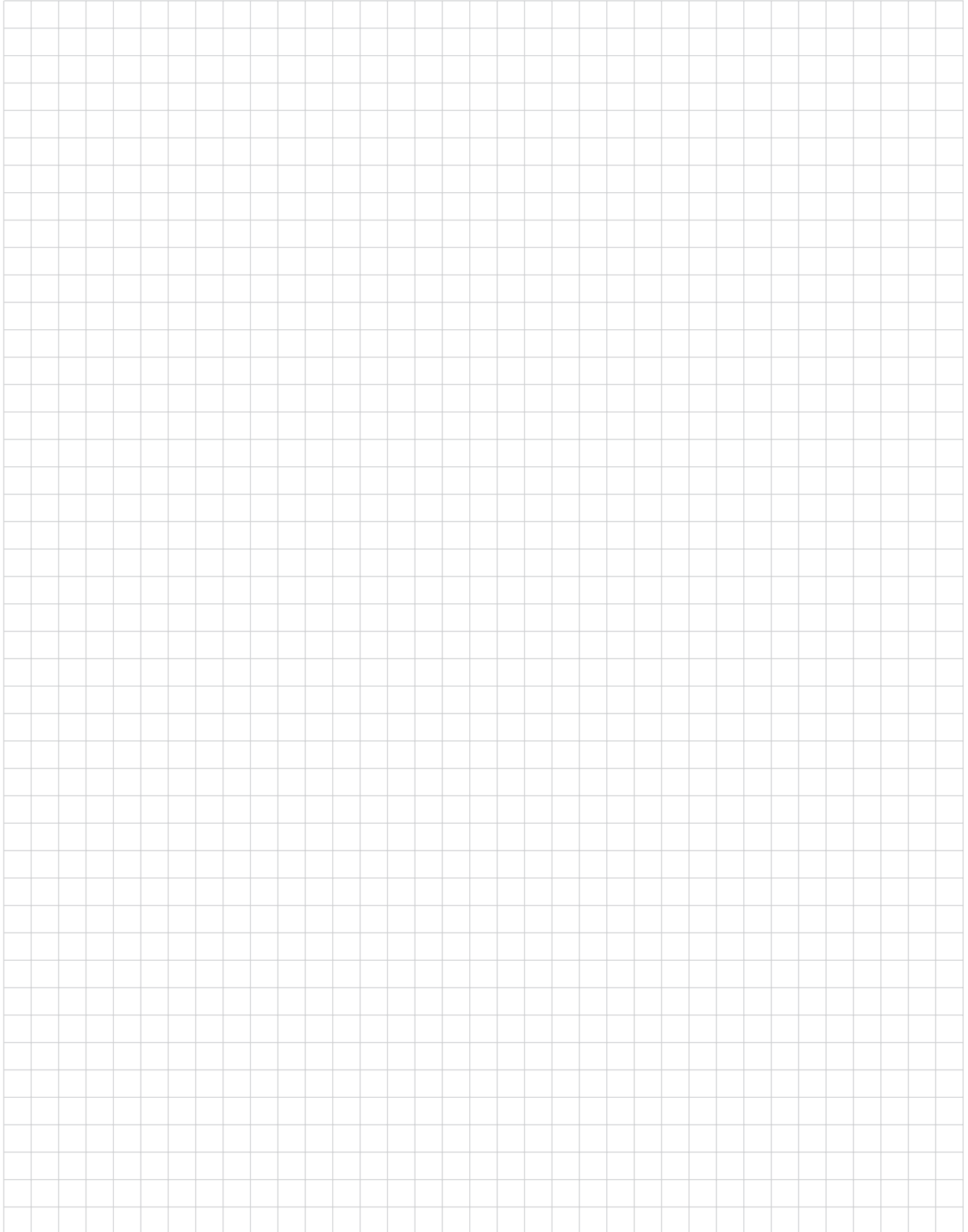

Germany

**09221 Neukirchen/Chemnitz**  
 Registriertechnik  
 Dipl.-Ing. Jörg Müller  
 Hauptstraße 148A  
 Tel. +49-(0)3713-30 47 89  
 Fax +49-(0)3713-30 47 89  
 Registriertechnikmueller@t-online.de

**22149 Hamburg**  
 Hermann Seidel GmbH  
 Techn. Vertretungen  
 Rahlstedter Str. 16  
 Tel. +49-(0)40-675085-0  
 Fax +49-(0)40-675085-85  
 seidel.gmbh@t-online.de

**28876 Oyten**  
 Fritz Kübler GmbH  
 Zähl- und Sensortechnik  
 Vertriebsbüro Nord  
 Herr Herrmann  
 Mohrblumenweg 6  
 Tel. 04207-6880-32  
 Fax: 04207-6880-34

**35759 Driedorf**  
 Fritz Kübler GmbH  
 Zähl- und Sensortechnik  
 Vertriebsbüro Mitte  
 Gartenstraße 10  
 H. Stefan Heinigk  
 Tel. +49-(0)2775-5784-27  
 Fax +49-(0)2775-5784-28  
 stefan.heinigk@kuebler.com

**42499 Hückeswagen**  
 Fuhrmeister & Co.  
 Industrievertretungen GmbH  
 Stahl Schmidtsbrücke 38  
 Tel. 02192-851122  
 Fax 02192-851127  
 info@fuhrmeister-gmbh.de  
 www.fuhrmeister-gmbh.de

**66287 Quierschied-Göttelborn**  
 Herbert Neundörfer  
 GmbH & Co. KG  
 Werksvertretungen  
 Zum Schacht 9  
 Tel. 0 68 25 95 45 0  
 Fax 0 68 25 95 45 99  
 info@herbert-neundoerfer.de  
 www.herbert-neundoerfer.de

**78023 Villingen-Schwenningen**  
 Fritz Kübler GmbH  
 Zähl- und Sensortechnik  
 Postfach 34 40  
 Tel. +49-(0)7720-39 03-0  
 Fax +49-(0)7720-21564  
 sales@kuebler.com  
 www.kuebler.com

**78549 Spaichingen**  
 Fritz Kübler GmbH  
 Zähl- und Sensortechnik  
 Vertriebsbüro Süd-West  
 Karl Klaritsch  
 Eichenweg 1  
 Tel. +49 (0) 74 24 94 90 69  
 Fax +49 (0) 74 24 94 90 87  
 Mobil: +49 (0) 174 3 22 59 41  
 karl.klaritsch@kuebler.com  
 www.kuebler.com

**88662 Überlingen**  
 Fritz Kübler GmbH  
 Zähl- und Sensortechnik  
 Vertriebsbüro Süd-Ost  
 Stefan Rost  
 Burgberggring 91  
 Tel. 07551 93 63 75  
 Fax 07551 93 64 92  
 stefan.rost@kuebler.com  
 www.kuebler.com

**German catalogue distributors:**

**64546 Mörfelden-Walldorf**  
 RS Components GmbH  
 Hessenring 13 b  
 Tel. +49-(0)6105-401234  
 www.rs-components.de

**82041 Oberhaching**  
 Farnell InOne GmbH  
 Keltenring 14  
 Tel.: 089-61 39 39 39  
 www.farnellinone.de

**82069 Hohenschäftlarn**  
 Bachmann  
 Electronic GmbH  
 Am Wagnerfeld 4  
 Tel. 08178-8676-0  
 Fax: 08178-8676-50  
 info@bachmann-electronic.de  
 www.bachmann-electronic.de

**92240 Hirschau**  
 Conrad Electronic GmbH  
 Klaus-Conrad-Straße 1  
 Tel. +49-(0)9604-4089-88  
 www.conrad.com

Europe

**Austria**  
 Gebhard Balluff GmbH + Co.  
 Industriestraße B16  
 A-2345 Brunn am Gebirge  
 Tel. +43 0 22 36 3 25 21-0  
 Telefax +43 0 22 36 3 25 21 46  
 sensor@balluff.at  
 www.balluff.at

**Belarus**  
 FEK Company  
 ul. Engelsa, 30  
 BY-220030 Minsk  
 Tel. +375 17 210 59 57  
 Fax +375 17 227 53 13  
 turck@infonet.by  
 www.turck.by

**Belgium**  
 Electromechanical counters:  
 Crouzet S.A.  
 Avenue Roi Albert I, 40  
 B-1780 Wemmel  
 Tel. +32 2 462 07 30  
 Fax +32 2 461 00 23  
 awesdijk@crouzet.com  
 www.crouzet.com

**Electronic counters**  
 DURANMATIC BV  
 Jan Valsterweg 50  
 NL-3315 CV Dordrecht  
 Tel. +31 78 631 05 99  
 Telefax +31 78 613 11 33  
 info@duranmatic.nl  
 www.duranmatic.nl

**Encoders and process products:**  
 Multiprox N.V.  
 P.b. 71 Lion d'Orweg 12  
 B-9300 Aalst  
 Tel.: +32-0 53 766 566  
 Fax: +32-0 53 783 977  
 mail@multiprox.be  
 www.multiprox.be

**Bulgaria**  
 Sensomat GmbH  
 D-r Ivan Penakov Str 15-W-4-11  
 9300 Dobritsch  
 Tel.: +359-58-603023  
 Fax: +359-58-603033  
 info@sensomat.info  
 www.sensomat.info

**Czech Republic**  
 TURCK s.r.o  
 Hradecká 1151  
 CZ-500 03 Hradec Králové  
 Tel. +420-4 955 187 66  
 Fax +420-4 955 187 67  
 turck@turck.cz  
 www.turck.cz

**Denmark**  
 Hans F elsgaard A/S  
 Ejby Industrivej 30  
 2600 Glostrup  
 Denmark  
 Tel. + 45 43 20 86 25  
 Fax + 45 43 96 88 55  
 psh@hf.net  
 www.hf.net

**Estonia**  
 Standel AS  
 Kiisa 8  
 11313 Tallinn  
 Estonia  
 Tel (+372) 6 558 180  
 Fax (+ 372) 6 558 179  
 standel@standel.ee  
 www.standel.ee

**Finland**  
 Murrelektronik OY  
 Koukkukatu 1  
 FIN-15700 Lahti  
 Tel. +358 3 882 4000  
 Telefax +358 3 882 4040  
 myynti@murrelektronik.fi  
 www.murrelektronik.fi

**France**  
 Fritz Kübler S.à.r.l.  
 Compteurs et codeurs indus-  
 triels  
 195 rue de Soutz  
 F-68270 Wittenheim  
 Tel. +33 3 89 53 45 45  
 Telefax +33 3 89 53 66 77  
 E-Mail:  
 info@kuebler-sarl.com  
 www.kuebler-sarl.com

**Great Britain**  
**Encoders:**  
 OEM Automatic Ltd  
 Whiteacres, Cambridge Road  
 Whetstone  
 Leicestershire LE8 6ZG  
 Tel. +44 116 284 99 00  
 Telefax +44 116 284 17 21  
 information@uk.oem.se  
 www.oem.co.uk

**Counters and process products:**  
 Leuze Mayser electronic Ltd.  
 Generation Business Park  
 Barford Rd  
 St. Neots  
 Cambs PE19 6YQ, UK  
 Tel. +44 14 80-408 500  
 Telefax +44 14 80-403 808  
 mail@leuzemayser.co.uk  
 www.leuzemayser.co.uk

**Greece**  
 Industrial Automation Systems  
 L.J. Skourgialos  
 241, El. Venizelou Ave.  
 176 73 Kallithea - Athens  
 Greece  
 Tel.: +30 210 9510260  
 Fax: +30 210 9511048  
 info@ias.gr  
 www.ias.gr

**Hungary**  
 Kvalix Automatika Kft.  
 Kiss Ernő u. 1-3  
 H-1046 Budapest  
 Tel. +36 1 272 2242  
 Fax +36 1 272 2244  
 info@kvalix.hu  
 www.kvalix.hu

**Ireland**  
 Irish Industrial Components Ltd.  
 Unit 18/2, Canal Turn,  
 Clondalkin Industrial Estate  
 IRL-Clondalkin, Dublin 22  
 Tel. +353 1 45 70 012  
 Telefax +353 1 45 70 609  
 info@iicltd.ie  
 www.iicltd.ie

**Iceland**  
 Reykjafell Ltd.  
 Skipholt 35  
 IS-125 Reykjavik  
 Tel. +354 588 6010  
 Telefax +354 588 6088  
 reykjafell@reykjafell.is  
 www.reykjafell.is

**Italy**  
**Encoder-Division:**  
 Kübler Italia Srl.  
 Viale F. Testi 287  
 I-20126 Milano  
 Tel. +39 0 26 42 33 45  
 Fax +39 0 26 61 13 843  
 alfredo.angeli@kuebler.com  
 www.kuebler.com

*Exclusive representative for counters and process products, preferred distributor for encoders:*  
 MASAUTOMAZIONE S.R.L.  
 Via G. Galilei 20  
 I-20090 Segrate (MI)  
 Tel. +39 02 26 92 20 90  
 Fax +39 02 26 92 16 87  
 info@masautomazione.it  
 www.masautomazione.it

**Netherlands**  
**Electromechanical counters:**  
 Crouzet BV  
 Industrierweg 17  
 NL-2382 NR Zoeterwoude  
 Tel. +31 71 541 11 21  
 Telefax +31 71 541 35 74  
 com-nl@crouzet.com  
 www.crouzet.com

**Electronical counters, process devices and encoders:**  
 DURANMATIC BV  
 Jan Valsterweg 50  
 NL-3315 CV Dordrecht  
 Tel. +31 78 631 05 99  
 Telefax +31 78 613 11 33  
 info@duranmatic.nl  
 www.duranmatic.nl

**Norway**  
 ELTECO A.S.  
 Postboks 96  
 N-3901 Porsgrunn  
 Tel. +47 35 56 20 70  
 Fax +47 35 56 20 99  
 sh@elteco.no  
 www.elteco.no

**Poland**  
 Kübler Polska Sp. z o.o.  
 ul. Dabrowskiego 441  
 60-451 Poznan  
 Poland  
 Tel.: +48 (0) 61 849 99 02  
 Fax: +48 (0) 61 849 99 03  
 sales@kubler.pl  
 www.kubler.pl

ASTAT sp. z o.o.  
 ul. Dabrowskiego 441  
 60-451 Poznan  
 Poland  
 Tel. +48 (0) 6 18 48 88 71  
 Fax +48 (0) 6 18 48 82 76  
 info@astat.com.pl  
 www.astat.com.pl

**Electronic Counters and process devices:**  
 IMPOL-1 Sp.j.  
 ul. Krakowiaków 103  
 02-255 Warszawa  
 tel. +48 22 886 56 02  
 fax +48 22 886 56 04  
 impol@impol-1.pl  
 www.impol-1.pl

**Encoders:**  
 OEM AUTOMATIC Sp. z o.o.  
 ul. Parowcowa 6B  
 02-445 Warszawa  
 Tel.: +48 22 863 27 22  
 Fax: +48 22 863 27 24  
 info@pl.oem.se  
 www.oemautomatic.com.pl

**Portugal**  
 LA2\*P, Lda.  
 Rua Teófilo Braga, 156 A  
 Escrit. F - Edificio S. Domingos  
 Cabeço do Moura  
 2785 - 122 S. Domingos de Rana  
 Tel. +351 21 444 70 70  
 Fax +351 21 444 70 75  
 geral@la2p.pt  
 www.la2p.pt

**Romania**  
 Syscom SRL  
 Calea Plevnei 139, Sector 6  
 ROM-Bucharest 77131  
 Tel. +040 21 310 26 78  
 Fax +040 21 316 91 76  
 vasile.enache@syscom18.com  
 www.syscom.ro

**Russia**  
 Servotechnica ZAO  
 22, Vyborgskaya str  
 125130 Moscow  
 Tel. +7 4 95 797 88 56  
 Fax +7 4 95 450 00 43  
 info@servotechnica.ru  
 www.servotechnica.ru

**Serbia**  
 Rapelectronics d.o.o  
 Rabina Alkalaja 16  
 ZEMUN, Beograd  
 YU-11080  
 Tel. +381 11 3161 229  
 Fax +381 11 3075 035  
 rapelectronic@sezampro.yu  
 www.rapel.co.yu

**Slovakia**  
 Balluff Slovakia s. r. o  
 Jána Bottu 4  
 974 01 Banská Bystrica  
 Tel. +421 48 414 83 86/7  
 Fax +421 48 414 83 69  
 sekretariat@s-a.sk  
 www.kuebler.sk

**Slovenia**  
 SENZORJI SB d.o.o.  
 Ulica Kirbiševih 53a  
 2204 Miklav na Dravskem polju  
 Slovenia  
 Tel.: +386 2 6 29 03 00  
 Fax: +386 2 6 29 03 02  
 senzorji.sb@siol.net  
 www.senzorji-sb.si

**Spain**  
 Elion, S.A.  
 Farell, 5  
 E-08014 Barcelona  
 Tel. +34 93 298 20 00  
 Fax +34 93 431 18 00  
 elion@elion.es  
 www.elion.es

**Sweden**  
**Counters and process products**  
 Flexitron AB  
 Box 7117  
 S-18712 Täby  
 Tel. +46 87 32 85 60  
 Telefax +46 87 569 132  
 sales@flexitron.se  
 www.flexitron.se

**Encoders:**  
 OEM AUTOMATIC AB  
 Dalagatan 4, Box 1011  
 S-57328 Tranås  
 Tel.: +46 75-242 4100  
 Fax: +46 75-242 4119  
 info@aut.oem.se  
 www.oemautomatic.se

**Switzerland**  
 Micronor AG  
 Pumpwerkstrasse 32  
 CH 8105 Regensdorf  
 Tel. : +41 (0) 1 843 40 20  
 Fax: +41 (0) 1 843 40 39  
 sales@micronor.ch  
 www.micronor.ch

**Turkey**  
 ERUZ Elektrik San. ve Tic. A.S.  
 Necatibey Caddesi  
 Demirbag Han Kat 1  
 TR-80030 Karaköy-Istanbul  
 Tel. +90 212 2 93 60 36  
 Fax +90 212 24 45 156  
 eruzelektrik@superonline.com  
 www.eruzelektrik.com.tr



## Europe

### European catalogue distributors:

#### Austria

Farnell InOne GmbH,  
Birkenstraße 2  
5300Salzburg/Hallwang  
Tel. +43 (0) 662 - 218 06 80  
Fax +43 (0) 662 - 218 06 70  
verkauf.at@farnellinone.com

RS Components  
Albrechtser Straße 11  
A-3950 Gmünd  
Tel. +43 28 52 505  
Telefax +43 28 52 53 223  
www.rs-components.at

#### France

Radiospares Composants  
Rue Norman King BP 453  
F-60031 Beauvais CEDEX  
Tel. +33 3 44 10 16 48  
Telefax +33 3 44 10 16 44  
www.radiospares.fr

Farnell InOne  
745 avenue de l'Europe  
F-69400 Villerfranche sur Saône  
Tel. +33 4 74 68 99 99  
Fax +33 4 74 68 99 90  
www.farnellinone.fr  
ventes@farnellinone.fr

#### Great Britain

RS Components Ltd.  
PO Box 99, Corby  
Northants NN17 9RS  
Tel. +44 15 36 201 234  
Telefax +44 15 36 40 56 78  
www.rswww.com

Farnell InOne  
Canal Road  
Leeds LS12 2TU  
Tel. +44 87 01 200 200  
Fax +44 87 01 200 201  
sales@farnellinone.co.uk

#### Italy

RS Components S.p.A.  
Via De Vizzi 93/95  
20092, Cinisello Balsamo,  
Milano  
Tel. +39 02 660 581  
Fax +39 02 660 580 51  
www.rs-components.it  
www.rs.com

Distrelec Italia s.r.l.  
C.P. 90  
20020Lainate (Mi)  
Tel. +39 02-937551  
Fax +39 02-93755755  
info-it@distrelec.com  
www.distrelec.com

#### Switzerland

Distrelec AG  
Grabenstrasse 6  
CH-8606 Nänikon  
Tel. +41-944 95 36  
Fax +41-944 99 88  
www.distrelec.com

Farnell InOne  
Brandschenkestraße 178  
8027 Zürich  
Tel. +41 (0) 1 - 204 64 64  
Fax +41 (0) 1 - 204 64 54  
verkauf.ch@farnellinone.com

## Overseas

#### Argentina

AUMECON S.A.  
Acassuso 4768  
1605 Munro  
Prov. de Buenos Aires  
Tel. +54 11 47 56 1251  
Telefax +54 11 47 62 63 31  
ventas@amecon.com.ar  
www.amecon.com.ar

#### Australia

Balluff Leuze Pty. Ltd.  
12 Burton Court  
Bayswater VIC, 3179  
Tel. +61 3 97 20 41 00  
Fax +61 3 97 38 26 77  
sales@balluff.com.au  
www.balluff.com.au

#### Brazil

Balluff Controles Elétricos Ltda.  
Rua Francisco Foga 25,  
Cx. Postal 189  
CEP 13280-000 Vinhedo-SP  
Tel. +55 19 38 76 99 99  
Fax +55 19 38 76 99 90  
balluff@balluff.com.br  
www.balluff.com.br

#### Canada

Connectic Systems Inc.  
28-207 Edgeley Boulevard, Unit  
28  
CDN-Concord, Ontario L4K 4B5  
Tel. +1 905 669 00 80  
Telefax +1 905 669 00 82  
solisaa@connectic.com  
www.connectic.com

#### Chile

Electronica industrial  
El Schädler y Cia. Ltda.  
Casilla 189-9  
Av. Antonio Varas 1871  
Providencia  
Santiago  
6641545  
Tel. +56 2 274 74 30  
Telefax +56 2 204 93 38  
schadler@interactiva.cl

#### China

Turck (Tianjin) Sensor Co., Ltd.  
18,4 th Xinghuazhi Rd.,Xiqing  
Economic Development Zone  
300381 Tianjin.  
Tel. +86 22 83 98 81 88  
Fax +86 22 83 98 81 11  
xiangbin.xuan@turck-china.com

#### Hong Kong

PO KWONG ELECTRIC (HONG  
KONG) LIMITED  
Rm. 1617-1618,  
Parklane Centre  
25 Kin Wing St., Tuen Mun, N.T.  
Tel. +852 24 23 66 22  
Fax +852 24 61 10 02  
sales@pokwong.com  
www.pokwong.com

#### Egypt

AES Advanced Electronic Engi-  
neering  
26, Rabaa Bldgs., Nozha St.  
ET-Nasr City, Cairo  
Tel. +20 2 418 50 20  
Fax +20 2 418 53 70  
sales@aee.com.eg  
www.aee.com.eg

#### India

Rajdeep Automation Pvt. Ltd.  
Survey 143, 3rd Floor, Sinhaghad  
Road,  
Vadgaon Dhayari, Pune 411041  
Tel: +91 20 24 39 37 55  
Fax: +91 20 24 39 37 56  
info@rajdeep.in  
www.rajdeep.in

#### Indonesia

SUPRA Engineering  
Jl. Pecenongan 17 D  
Rl-10120 Jakarta  
Tel. +62 21 345 73 55  
Telefax +62 21 345 73 18  
astina@centrin.net.id  
www.supra.co.id

#### Israel

Omega Engineering LTD  
P.O. BOX 13825  
Netanya 42138  
Tel. +972-9-767 3240  
Fax. +972-9-767 3398  
info@omega.co.il  
www.omega.co.il

#### Japan

Kasuga Electric Works Ltd  
1-33 Shimorenjaku 6-Chome  
181-8518 Mitaka, Tokyo  
Tel. +81 4224 172 11  
Fax +81 4224 189 00  
info@kasuga.jp  
www.kasuga.jp

#### Lebanon

Elias Ghali & Son's  
Sabteihe  
Beirut  
Tel. + 963 31 22 20 789  
Fax: + 961 16 86 255  
sghali1@cyberia.net.lb  
www.ghali-sy.com

#### Malaysia

INGERMARK (M) SDN. BHD.  
No.29, Jalan KPK 1/8,  
Kawasan Perindustrian Kun-  
dang,  
48020 Rawang,  
Selangor Darul Ehsan  
Tel.: +60-3-7980 9591  
Fax: +60-3-7981 7442  
ingmal@tm.net.my

#### New Zealand

Carrel & Carrel Ltd.  
3, Mc Donald St.  
Morningside  
NZ-Auckland 1003  
Tel. +64 9 846 91 24  
Telefax +64 9 846 85 55  
sales@carrel.co.nz  
www.carrel.co.nz

#### Philippines

Technorand Sales Corporation  
Wilshire Annapolis Plaza,  
Annapolis Street  
San Juan, Metro Manila 1500  
Tel. +63 716-5990  
Fax +63 716-5986  
techno@compass.com.ph

#### Singapore

Raymond International Pte. Ltd.  
Blk 219 Henderson Road #07-04  
Henderson Industrial Park  
Singapore 159556  
Tel. +65 62 76 37 38  
Fax +65 62 76 37 39  
raymond@raymond.com  
www.raymond.com

#### South Africa

RET Automation Controls  
130 Boeing Road East  
ZA-Bedfordview 2008  
Tel. +27 11 453 24 68  
Telefax +27 11 453 24 06  
rodneyt@retauto.co.za  
www.retauto.co.za

#### South Korea

F & B Solution Co.  
578, Kwaebop-dong, Sasang-ku  
Pusan Industrial Supplies Mar-  
ket 9-116  
PUSAN  
Tel. +82 51 319 12 30  
Fax +82 51 319 12 50  
ihbae@fastnbest.com  
www.fastnbest.com

#### Syria

Elias Ghali & Son's  
P.O.Box 64  
SYR-Homs  
Tel. + 963 31 24 80 780  
Fax: + 963 31 2 227 638  
s.ghali@scs-net.org  
www.ghali-sy.com

#### Taiwan, R.O.C.

*Counters and process products:*  
Canaan Electric Corp.  
6F-5, No. 63, Sec. 2  
Chang An East Road  
Taipei  
Tel. +886 225 08 23 31  
Telefax +886 225 08 47 44  
sales@canaan-elec.com.tw  
www.canaan-elec.com.tw

#### Encoders:

Maintech Technology Co. Ltd.  
7F-3, No. 13, Wu-Chun 1 Rd.  
Hsin Chuang  
Taipei Hsien City 242  
Tel. +886 222 99 29 50  
Fax +886 222 99 54 13  
mtt@mtt.com.tw  
www.mtt.com.tw

#### Thailand

Technology Instrument Co., Ltd.  
208/132-137 Moo 6 Patanakarn  
Rd., Pravet, Bangkok 10250  
Tel. +662 3 22 22 33  
Fax +662 7 22 30 47  
marketing@tic.co.th  
www.tic.co.th

#### Tunisia

H2M Technologies  
13, Rue El Moutanabi  
TN-2037 El Menzah 7 -Tunis  
Tel. +216 71 42 76 77  
Fax +216 71 42 76 88  
h2m.tech@planet.tn

#### U.S.A.

Counting and Process  
technology  
Global Industrial Products Inc.  
3338 West Lake Ave.  
Glenview, IL 60026  
Toll-free number:  
1-800-951-8774  
Tel. +1 847 901 4040  
Fax +1 847 901 4036  
sales@globalepower.com  
www.kueblerusa.com

Rotary and linear encoders  
"Kübler by Turck"  
Turck Inc.  
3000 Campus Drive  
Minneapolis MN 55441  
Tel. +1 763 553 7300  
Fax +1 763 553 0708  
sensors@turck.com  
www.kueblerbyturck.com  
www.turck.com

Partner for selected counters  
and Process technology  
Kessler-Ellis Products Co.  
sales@kep.com  
www.kep.com